

PEETER JOOT
CONTINUUM MECHANICS

CONTINUUM MECHANICS

PEETER JOOT

Notes and problems from UofT PHY454H1S 2012

+0200 – version Vo.1.10-12

COPYRIGHT

Copyright ©2019 Peeter Joot All Rights Reserved

This book may be reproduced and distributed in whole or in part, without fee, subject to the following conditions:

- The copyright notice above and this permission notice must be preserved complete on all complete or partial copies.
- Any translation or derived work must be approved by the author in writing before distribution.
- If you distribute this work in part, instructions for obtaining the complete version of this document must be included, and a means for obtaining a complete version provided.
- Small portions may be reproduced as illustrations for reviews or quotes in other works without this permission notice if proper citation is given.

Exceptions to these rules may be granted for academic purposes: Write to the author and ask.

Disclaimer: I confess to violating somebody's copyright when I copied this copyright statement.

DOCUMENT VERSION

Version V0.1.10-12

Sources for this notes compilation can be found in the github repository

[git@github.com:peeterjoot/phy454-continuumechanics.git](https://github.com/peeterjoot/phy454-continuumechanics.git)

The last commit (Sep/23/2019/+0200), associated with this pdf was

5a57b157901e64deod51395ac06e9318a8a10c9b

Should you wish to actively contribute typo fixes (or even more significant changes) to this book, you can do so by contacting me, or by forking your own copy of the associated git repositories and building the book pdf from source, and submitting a subsequent merge request.

```
#!/bin/bash

git clone git@github.com:peeterjoot/latex-notes-
  compilations.git peeterjoot
cd peeterjoot

submods="figures/phy454-continuumechanics phy454-
  continuumechanics mathematica latex"
for i in $submods ; do
  git submodule update --init $i
  (cd $i && git checkout master)
done

export PATH='pwd'/latex/bin:$PATH

cd phy454-continuumechanics
make
```

I reserve the right to impose dictatorial control over any editing and content decisions, and may not accept merge requests as-is, or at all. That said, I will probably not refuse reasonable suggestions or merge requests.

Dedicated to:

Aurora and Lance, my awesome kids, and
Sofia, who not only tolerates and encourages my studies, but is
also awesome enough to think that math is sexy.

PREFACE

This book is based on my lecture notes for the Winter 2012, University of Toronto Continuum Mechanics course (PHY454H1S), taught by Prof. Kausik S. Das.

My thanks to Professor Das for teaching this course. It covered the fundamentals of fluid dynamics in a sensible and logical fashion, providing a great base for further learning.

Official course description:

The theory of continuous matter, including solid and fluid mechanics. Topics include the continuum approximation, dimensional analysis, stress, strain, the Euler and Navier-Stokes equations, vorticity, waves, instabilities, convection and turbulence.

What you will find in this book:

- My lecture notes.
- Problem sets and midterm solutions. These have been incorporated into the lecture material as chapter end problems with solutions.
- Some worked problems attempted for fun or for exam preparation.
- Links to Mathematica workbooks associated with course content.

Peeter Joot peeterjoot@pm.me

CONTENTS

Preface xi

1	INTRODUCTION.	1
1.1	Continuum Mechanics.	1
1.2	Nomenclature and basic definitions.	2
1.3	Texts.	3
2	STRAIN TENSOR.	5
2.1	Deformations.	5
2.2	Strain matrix representation and volume element.	8
2.3	Strain in cylindrical coordinates.	10
2.4	Compatibility condition for 2D strain.	10
2.5	Compatibility condition for 3D strain.	12
2.6	On the factor of two in the tensor definition.	13
2.7	Summary.	14
2.7.1	Strain Tensor.	14
2.7.2	Diagonal strain representation.	15
2.7.3	Strain in cylindrical coordinates.	15
2.7.4	Compatibility condition.	16
2.8	Problems.	17
3	STRESS TENSOR.	21
3.1	Force per unit volume.	21
3.2	Stress tensor in 2D.	25
3.3	Stress tensor in 3D.	27
3.4	Cauchy tetrahedron.	28
3.5	Constitutive relation.	31
3.6	Constitutive relation, hydrostatic compression.	32
3.7	Constitutive relation for uniaxial stress.	33
3.8	Summary.	35
3.8.1	Stress tensor.	35
3.8.2	Constitutive relation.	36
3.8.3	Uniform hydrostatic compression.	36

3.8.4	Uniaxial stress. Young's modulus. Poisson's ratio.	36
3.9	Problems.	37
4	ELASTODYNAMICS.	47
4.1	Elastic waves.	47
4.2	P-waves.	48
4.3	S-waves.	50
4.4	Relative speeds of the p-waves and s-waves.	50
4.5	Assuming a gradient plus curl representation.	51
4.6	A couple summarizing statements.	52
4.7	Phasor description of elastic waves.	52
4.8	Some wave types described.	53
4.9	Summary.	54
4.9.1	Elastic displacement equation.	54
4.9.2	Equilibrium.	54
4.9.3	P-waves.	54
4.9.4	S-waves.	55
4.9.5	Scalar and vector potential representation.	55
4.9.6	Phasor description.	56
4.9.7	Some wave types.	56
4.10	Problems.	57
5	NAVIER-STOKES EQUATION.	63
5.1	Time dependent displacements.	63
5.2	Comparing to elastostatics.	65
5.3	Antisymmetric term, the vorticity.	65
5.4	Symmetric term, the strain tensor.	67
5.5	Newtonian Fluids.	67
5.6	Dimensions of viscosity.	68
5.7	Conservation of mass in fluid.	69
5.8	Incompressible fluid.	71
5.9	Conservation of momentum (Navier-Stokes equation).	71
5.10	Incompressible fluids.	73
5.11	Boundary value conditions.	73
5.12	Normals and tangents at fluid interfaces.	73
5.13	Solutions by intuition.	83
5.14	Summary.	92

5.14.1	Vector displacements.	92
5.14.2	Relative change in volume.	93
5.14.3	Conservation of mass.	94
5.14.4	Constitutive relation.	94
5.14.5	Conservation of momentum (Navier-Stokes).	94
5.14.6	Observe the first order time derivative here.	94
5.14.7	No slip condition.	95
5.14.8	Traction vector matching at an interface.	95
5.14.9	Flux.	96
5.15	Problems.	96
6	HYDROSTATICS.	155
6.1	Steady state and static fluids.	155
6.2	Height matching in odd geometries.	158
6.3	Summary.	160
6.3.1	Hydrostatics.	160
6.3.2	Mass conservation through apertures.	160
7	BERNOULLI'S THEOREM.	161
7.1	Derivation.	161
7.2	Summary.	162
7.2.1	Bernoulli equation.	162
7.3	Problems.	163
8	SURFACE TENSION.	171
8.1	Traction vector at the interface.	171
8.2	Surface tension gradients.	173
8.3	Summary.	174
8.3.1	Laplace pressure.	174
8.3.2	Surface tension gradients.	174
8.3.3	Surface tension for a spherical bubble.	175
8.4	Problems.	176
9	NONDIMENSIONALISATION.	179
9.1	Scaling.	179
9.2	Rescaling by characteristic length and velocity.	179
9.3	Reynold's number.	181
9.4	Summary.	183
9.4.1	Non-dimensionality and scaling.	183

9.5	Problems.	184
10	BOUNDARY LAYERS.	189
10.1	Time dependent flow.	189
10.2	Unsteady rectilinear flow.	190
10.3	Review. Impulsively started flow.	195
10.4	Boundary layers.	196
10.5	Universal behavior.	198
10.6	Fluid flow over a solid body.	201
10.6.1	Scaling arguments.	201
10.7	Summary.	214
10.7.1	Impulsive flow.	214
10.7.2	Oscillatory flow.	215
10.7.3	Blassius problem (boundary layer thickness in flow over plate).	215
10.8	Problems.	216
11	SINGULAR PERTURBATION THEORY.	225
11.1	Magnitude of the viscosity and inertial terms.	225
11.2	Asymptotic solutions of ill conditioned equations.	227
11.3	Summary.	235
11.3.1	Singular perturbation theory.	235
12	THERMAL EFFECTS AND STABILITY.	237
12.1	Stability.	237
12.1.1	Stability. Some graphical illustrations.	237
12.2	Characterizing stability.	238
12.2.1	Case I. Oscillatory instability.	240
12.2.2	Case II. Marginal instability.	240
12.2.3	Case III. Neutral stability.	240
12.3	A mathematical description.	240
12.4	Thermal stability review. Rayleigh Benard Problem.	243
12.5	Energy perturbation.	245
12.6	Non-dimensionalisation, thermal velocity.	245
12.7	Non-dimensionalization of the energy equation.	246
12.8	Normal mode analysis.	247
12.9	Back to our coupled equations.	249
12.10	Multimedia presentations.	252

12.11	Summary.	253
12.11.1	Stability.	253
12.11.2	Thermal stability: Rayleigh-Benard problem.	253
12.12	Problems.	256
A	STRAIN (NON-RECTANGULAR).	257
A.1	Cylindrical coordinates.	257
A.2	For general coordinate representation.	260
A.3	Cartesian tensor.	262
A.4	Cylindrical tensor.	263
A.5	Spherical tensor.	266
A.6	Spherical tensor. Manual derivation.	268
B	GEOMETRIC STRAIN AND TRACTION.	275
B.1	Motivation.	275
B.2	Verifying the relationship.	276
B.3	Cylindrical strain tensor.	277
B.3.1	Outwards radial normal $\hat{\mathbf{n}} = \hat{\mathbf{r}}$.	278
B.3.2	Azimuthal normal $\hat{\mathbf{n}} = \hat{\boldsymbol{\phi}}$.	279
B.3.3	Longitudinal normal $\hat{\mathbf{n}} = \hat{\mathbf{z}}$.	280
B.3.4	Summary.	281
B.4	Spherical strain tensor.	282
B.4.1	Outwards radial normal $\hat{\mathbf{n}} = \hat{\mathbf{r}}$.	283
B.4.2	Polar normal $\hat{\mathbf{n}} = \hat{\boldsymbol{\theta}}$.	285
B.4.3	Azimuthal normal $\hat{\mathbf{n}} = \hat{\boldsymbol{\phi}}$.	287
B.4.4	Summary.	289
C	POISSON'S RATIO, SHEAR MODULUS.	291
D	SURFACES.	293
D.1	Normals and tangents.	293
D.2	Review. Surfaces.	295
E	IDENTITIES AND PROOFS.	297
E.1	Error function properties.	297
E.2	A Fourier series refresher.	297
E.3	Vector identities.	298
F	GENERAL INCLINED FLOW PROBLEM.	299
F.1	Motivation.	299

F.2	Equations of motion.	300
F.3	Boundary value constraints.	301
F.4	Laplacian of Pressure and Vorticity.	304
F.4.1	Separation of variables?	304
F.4.2	In terms of vorticity?	305
F.4.3	Pressure and vorticity equations with the non-linear term retained.	306
F.4.4	Reworking slightly.	308
F.5	Now what?	311
G	INFINITE STIRRED COFFEE.	313
G.1	Motivation.	313
G.2	Navier-Stokes for the problem.	313
G.3	Base of cup no-slip troubles.	316
G.4	Spin down below the stir point.	319
H	MATHEMATICA NOTEBOOKS.	323
INDEX		329
BIBLIOGRAPHY		331

LIST OF FIGURES

Figure 1.1	Mass and volume ratios at different scales.	1
Figure 2.1	Deformation of a planar object.	5
Figure 2.2	Transformation under deformation of an infinitesimal line element along a trajectory.	6
Figure 2.3	Disjoint deformation illustrated.	12
Figure 2.4	Q2. Characteristic equation.	19
Figure 3.1	Internal forces.	21
Figure 3.2	Opposing stresses in one direction.	23
Figure 3.3	Mutually perpendicular forces.	24
Figure 3.4	Radial forces.	25
Figure 3.5	2D stress tensor.	25
Figure 3.6	General stress.	26
Figure 3.7	Area element under stress with and without rotation.	27
Figure 3.8	Strain components on a 3D volume.	27
Figure 3.9	Cauchy tetrahedron.	28
Figure 3.10	Cauchy tetrahedron direction cosines.	29
Figure 3.11	Area projection.	30
Figure 4.1	Illustrating changes in a control volume.	50
Figure 4.2	A 1D compression wave.	58
Figure 4.3	Rayleigh wave illustrated.	59
Figure 5.1	Differential displacement.	63
Figure 5.2	Area projections for mass conservation argument.	69
Figure 5.3	Rocker tank with two viscosity fluids.	73
Figure 5.4	Rocking tank velocity matching.	74
Figure 5.5	Normals and tangents at interface for 2D system.	74
Figure 5.6	Pressure gradient in 1D system.	77
Figure 5.7	Velocity variation with height in shearing flow.	79
Figure 5.8	1D Channel flow coordinate system setup.	81
Figure 5.9	Parabolic velocity distribution.	81

Figure 5.10	Normals in 1D channel flow system.	83
Figure 5.11	Simple shear flow.	83
Figure 5.12	Channel flow.	84
Figure 5.13	Flow on a plate.	84
Figure 5.14	Circulation flow induced by altering surface tension.	85
Figure 5.15	Flow through a pipe.	85
Figure 5.16	Gravity driven flow down an inclined plane.	88
Figure 5.17	Velocity streamlines for flow down a plane.	92
Figure 5.18	Velocity profile for 1D constant pressure gradient steady state flow.	99
Figure 5.19	Two layer flow induced by moving wall.	101
Figure 5.20	Two layer shearing flow with water over mercury.	104
Figure 5.21	Superposition of constant pressure gradient and shear flow solutions ($\mu^{(1)} > \mu^{(2)}$).	107
Figure 5.22	Superposition of constant pressure gradient and shear flow solutions ($\mu^{(1)} < \mu^{(2)}$).	107
Figure 5.23	$\mu^{(1)} > \mu^{(2)}$.	110
Figure 5.24	$\mu^{(2)} > \mu^{(1)}$.	110
Figure 5.25	Shearing flow with pressure gradient and one moving boundary.	113
Figure 5.26	Parabolic velocity profile.	116
Figure 5.27	Shear flow.	117
Figure 5.28	Superposition of shear and parabolic flow (low U).	117
Figure 5.29	Superposition of shear and parabolic flow (high U).	117
Figure 5.30	Two fluids layers in inclined flow.	121
Figure 5.31	Parabolic channel flow steady state, and difference from first Fourier term.	140
Figure 5.32	Difference from the steady state for the first five Fourier terms.	140
Figure 5.33	Couette flow configuration.	142
Figure 5.34	Couette flow plots.	148
Figure 5.35	Coordinates for flow between two cylinders.	149
Figure 5.36	Velocity plot due to inner cylinder dragging fluid along with it.	151

Figure 5.37	Pressure gradient added.	154
Figure 5.38	3D plots.	154
Figure 6.1	A control volume of fluid in a fluid.	155
Figure 6.2	Column of fluid above a control volume.	155
Figure 6.3	A mass of different density in a fluid.	156
Figure 6.4	Various floating ice configurations on water.	156
Figure 6.5	Flow through channel with different apertures.	157
Figure 6.6	Area and velocity flows in unequal aperture channel configuration.	157
Figure 6.7	Velocity variation in channel with bulge.	158
Figure 6.8	Vorticity induction due to pressure gradients in unequal aperture channel.	158
Figure 6.9	Vorticity due to rectangular blockage.	158
Figure 6.10	Height matching in odd geometries.	159
Figure 6.11	A physical demonstration with glass blown apparatus.	159
Figure 6.12	Column volume element decomposition for odd geometries.	160
Figure 7.1	Streamlines for the rotating bucket system.	166
Figure 7.2	Tap flow measurement.	168
Figure 7.3	Comparison of measured stream radii and calculated.	169
Figure 8.1	Vapor liquid interface.	171
Figure 8.2	Normal and tangent vectors on a curve.	172
Figure 8.3	Pressure and curvature relationships.	173
Figure 8.4	Example of non-spherical curvature.	173
Figure 8.5	Spherical bubble in liquid.	175
Figure 8.6	Curvature of fluid against a wall.	176
Figure 9.1	Coarse scaling example.	179
Figure 9.2	Fine grain scaling example (a zoom).	180
Figure 9.3	Moving and fixed frame control volumes in a fluid.	182
Figure 9.4	Viscous and non-viscous regions.	183
Figure 9.5	Viscous and non-viscous regions.	183
Figure 10.1	Flow lines around circular obstacle.	189
Figure 10.2	Viscous and inviscous regions in boundary layer flow.	189

Figure 10.3	Lagrangian and Eulerian views.	191
Figure 10.4	Plots of separation thickness for different viscosities.	195
Figure 10.5	Linear relation between separation thickness and \sqrt{vt} .	195
Figure 10.6	Impulsively driven time dependent fluid flow.	195
Figure 10.7	Error function.	197
Figure 10.8	Velocity profiles at different times.	197
Figure 10.9	Universal behavior.	198
Figure 10.10	Characteristic distances in heat flow problems.	199
Figure 10.11	Time dependent fluid motion due to oscillating plate.	199
Figure 10.12	Flow over a solid object with boundary layer.	202
Figure 10.13	Illustrating the boundary layer thickness and associated pressure variation.	206
Figure 10.14	Boundary layer solution to flow over plate.	214
Figure 10.15	Fluid flow in nested cylinders.	218
Figure 10.16	Bessel $J_1(\lambda_i z)$ zero crossings.	222
Figure 10.17	Bessel function fitting for the steady state velocity profile for $n = 1, 3, 5$.	223
Figure 11.1	Solution to the ill conditioned first order differential equation.	227
Figure 11.2	Plot of exact solution to simple first order ill conditioned LDE.	229
Figure 11.3	Plot of our ill conditioned second order LDE.	233
Figure 12.1	Stable well configuration.	237
Figure 12.2	Unstable peak configuration.	237
Figure 12.3	Stable tabletop configuration.	238
Figure 12.4	Displacement time evolution in undamped well system.	238
Figure 12.5	Displacement time evolution in damped well system.	239
Figure 12.6	Time evolution of displacement in unstable parabolic configuration.	239
Figure 12.7	Time evolution of displacement in tabletop configuration.	239

Figure 12.8	Fluid in cavity heated on the bottom plate.	241
Figure 12.9	Channel with heat applied to the base.	244
Figure 12.10	Critical Rayleigh's number.	251
Figure 12.11	Instability due to heating.	251
Figure 12.12	Crude illustration of instability leading to a drop pinching off.	252
Figure A.1	Composite rotations for spherical polar unit vectors.	269
Figure D.1	Variable surface geometries.	293
Figure D.2	A vector differential element.	294
Figure D.3	Variable surface geometries.	295
Figure D.4	A vector differential element.	296
Figure F.1	Gravitational force components acting on fluid flowing down a plane.	299
Figure F.2	Diagram of coordinates for inclined flow problem.	300
Figure F.3	Differential vector element.	301
Figure G.1	Vector field plot of the velocity field below the stir depth.	318
Figure G.2	Radial velocity dependence at the stir height.	318

1

INTRODUCTION.

1.1 CONTINUUM MECHANICS.

Mechanics could be defined as the study of effects of forces and displacements on a physical body. In continuum mechanics we have a physical body and we are interested in the internal motions in the object. For the first time considering mechanics we have to introduce the concepts of fields to make progress tackling these problems.

We will have use of the following types of fields

- Scalar fields. 3^0 components. Examples: density, Temperature, ...
- Vector fields. 3^1 components. Examples: Force, velocity.
- Tensor fields. 3^2 components. Examples: stress, strain.

We have to consider objects (a control volume) that is small enough that we can consider that we have a point in space limit for the quantities of density and velocity. At the same time we cannot take this limiting process to the extreme, since if we use a control volume that is sufficiently small, quantum and inter-atomic effects would have to be considered.

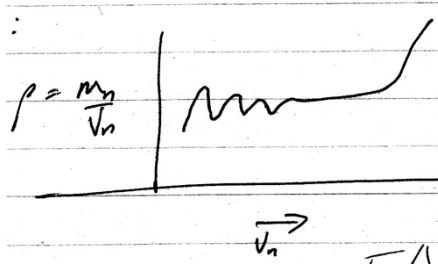

Figure 1.1: Mass and volume ratios at different scales.

1.2 NOMENCLATURE AND BASIC DEFINITIONS.

Most of this course is focused on just two concepts, that of strain and stress, and how they relate. We define

Definition 1.1: Strain

Measure of the deformation of the body, relating stretch and position.

Definition 1.2: Stress

Measure of the Internal force on the surfaces. This is a quantity constructed such that its divergence expresses the force per unit volume.

Definition 1.3: Constitutive relation

How strain and stress in a material are related.

Definition 1.4: Newtonian fluid

A fluid for which the constitutive relation is linear.

Defining these mathematically and using these concepts to model solid, liquid and gaseous materials will allow us to accurately predict the behavior of many types of continuous substances.

Building on these definitions we will end up discussing a number of other key concepts, such as

- Rheological. Study of the flow of matter, primarily in the liquid state. [19].
- Elastic waves
- Elastic/plastic
- Navier stokes relation: equivalent of Newton's law for fluids.

- Nondimensionalisation: parameter substitutions that put the differential equations of interest into dimensionless form.
- Boundary layer theory: investigation of the region of fluid flow around a solid where viscous forces dominate.
- Stability analysis
- Nonlinearity

1.3 TEXTS.

The lectures for this course loosely follow portions of the following texts

- **Elementary fluid dynamics** [2].
- **Theory of Elasticity** [13]

While these were not required reading, the Acheson text was particularly helpful in providing additional details about subjects covered in class, and for supplying useful problems for study.

STRAIN TENSOR.

2.1 DEFORMATIONS.

We have defined strain 1.1 as the measure of deformation of a body. This is a purely geometric definition, and by itself has no requirement to understand the forces that put the object into the deformed configuration. A mathematical statement of this definition needs to be made.

A solid deformation of an object with vertexes located at \mathbf{a} , \mathbf{b} , and \mathbf{c} is illustrated in fig. 2.1, where the deformed vertexes are located at \mathbf{a}' , \mathbf{b}' , and \mathbf{c}' . Identifying a specific point in the object

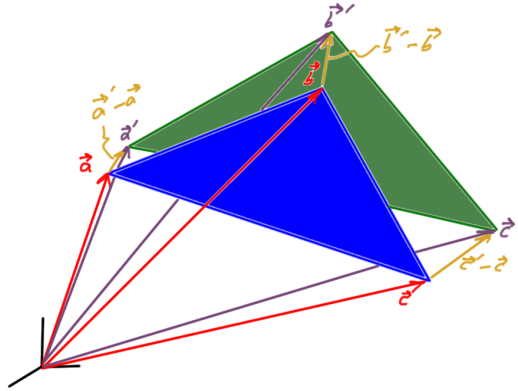

Figure 2.1: Deformation of a planar object.

with an undeformed position \mathbf{x} , we can consider the deformation of the object in the vicinity of this point. If this point has deformed position \mathbf{x}' , we define the *displacement vector*, the vectoral difference between the displaced and original point in the object, as

$$\mathbf{u} = \mathbf{x}' - \mathbf{x}, \quad (2.1)$$

or in coordinates

$$u_i = x'_i - x_i. \quad (2.2)$$

In general each of the displaced coordinate locations, and therefore also the displacement vector coordinates, is some function of position

$$\mathbf{x}' = \mathbf{f}(\mathbf{x}), \quad (2.3)$$

or in coordinates

$$x'_i = f_i(\mathbf{x}). \quad (2.4)$$

Now we will consider how a vector difference between two infinitesimally close points in the object change under deformation. Imagine that we are looking at points along some parameterized trajectory within the object as illustrated in fig. 2.2. In the original

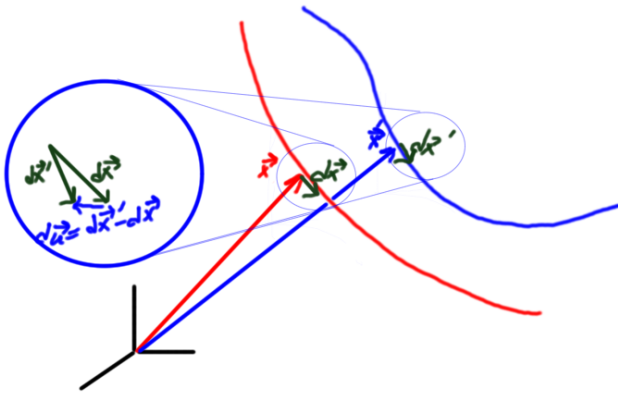

Figure 2.2: Transformation under deformation of an infinitesimal line element along a trajectory.

object, we can locate a point $\mathbf{y} = \mathbf{x} + d\mathbf{x}$ a little bit further along the parameterized path. In the deformed object we find this point at location $\mathbf{y}' = \mathbf{x}' + d\mathbf{x}'$. We wish to consider how this line element differs in the original and deformed configurations, indirectly calculating the magnitude of the difference

$$d\mathbf{u} = d\mathbf{x}' - d\mathbf{x}. \quad (2.5)$$

There are two ways we can perform this calculation. The first, following [13] §1, is to take a difference of the lengths of the displacement vector in the deformed and the original object. The

second, an approach we will use later in our treatment of fluids is to consider a linear expansion of the change in displacement between the deformed and original objects.

Rearranging for the displacement line element in the deformed object, and working in coordinates we write

$$dx'_i = dx_i + du_i \quad (2.6)$$

Employing summation convention with implied summation over repeated indices the lengths of the pairs of line elements are

$$\begin{aligned} dl &= |d\mathbf{x}| = \sqrt{dx_k dx_k} \\ dl' &= |d\mathbf{x}'| = \sqrt{dx'_k dx'_k}, \end{aligned} \quad (2.7)$$

or

$$dl'^2 = (dx_k + du_k)(dx_k + du_k) = dl^2 + 2dx_k du_k + du_k du_k. \quad (2.8)$$

Taylor expanding

$$du_i = \frac{\partial u_i}{\partial x_k} dx_k, \quad (2.9)$$

so that

$$du_i^2 = \frac{\partial u_i}{\partial x_k} dx_k \frac{\partial u_i}{\partial x_l} dx_l \quad (2.10)$$

$$\begin{aligned} dl'^2 &= dl^2 + 2 \frac{\partial u_i}{\partial x_k} dx_k dx_i + \frac{\partial u_l}{\partial x_i} \frac{\partial u_l}{\partial x_k} dx_i dx_k \\ &= dl^2 + \left(\frac{\partial u_i}{\partial x_k} + \frac{\partial u_k}{\partial x_i} \right) dx_k dx_i + \frac{\partial u_l}{\partial x_i} \frac{\partial u_l}{\partial x_k} dx_i dx_k \\ &= dl^2 + 2e_{ik} dx_i dx_k. \end{aligned} \quad (2.11)$$

We write

$$dl'^2 - dl^2 = 2e_{ik} dx_i dx_k, \quad (2.12)$$

where we define the *strain tensor* as

$$e_{ik} = \frac{1}{2} \left(\left(\frac{\partial u_i}{\partial x_k} + \frac{\partial u_k}{\partial x_i} \right) + \frac{\partial u_l}{\partial x_i} \frac{\partial u_l}{\partial x_k} \right). \quad (2.13)$$

In this course we will make use of only the linear terms, essentially defining the strain tensor as

$$e_{ij} = \frac{1}{2} \left(\frac{\partial u_j}{\partial x_i} + \frac{\partial u_i}{\partial x_j} \right). \quad (2.14)$$

2.2 STRAIN MATRIX REPRESENTATION AND VOLUME ELEMENT.

The strain tensor e_{ik} can be worked with in coordinates, but we will often use a matrix representation when working in Cartesian coordinates

$$\mathbf{e} = \begin{bmatrix} e_{11} & e_{12} & e_{13} \\ e_{21} & e_{22} & e_{23} \\ e_{31} & e_{32} & e_{33} \end{bmatrix}. \quad (2.15)$$

We see from eq. (2.13) that e_{ik} is symmetric, so we have

$$e_{21} = e_{12} \quad (2.16)$$

$$e_{31} = e_{13} \quad (2.17)$$

$$e_{32} = e_{23}. \quad (2.18)$$

Given this real symmetric matrix there must exist an orthonormal basis at each point that allows the strain tensor to be written in diagonal form

$$\bar{e}_{ik} = \begin{bmatrix} \bar{e}_{11} & 0 & 0 \\ 0 & \bar{e}_{22} & 0 \\ 0 & 0 & \bar{e}_{33} \end{bmatrix}. \quad (2.19)$$

In that basis the difference between two close points in the deformed object, in terms of the difference between the original positions of those points in the original object, can be expressed as

$$dx_1'^2 = (1 + 2\bar{e}_{11})dx_1^2 \quad (2.20)$$

$$dx_2'^2 = (1 + 2\bar{e}_{22})dx_2^2 \quad (2.21)$$

$$dx_3'^2 = (1 + 2\bar{e}_{33})dx_3^2, \quad (2.22)$$

or

$$dx_1' = \sqrt{1 + 2\bar{e}_{11}}dx_1 \quad (2.23)$$

$$dx_2' = \sqrt{1 + 2\bar{e}_{22}}dx_2 \quad (2.24)$$

$$dx_3' = \sqrt{1 + 2\bar{e}_{33}}dx_3. \quad (2.25)$$

If these points are close enough, we can employ a first order Taylor expansion of the square root, yielding

$$dx'_1 \approx (1 + \bar{e}_{11})dx_1 \quad (2.26)$$

$$dx'_2 \approx (1 + \bar{e}_{22})dx_2 \quad (2.27)$$

$$dx'_3 \approx (1 + \bar{e}_{33})dx_3. \quad (2.28)$$

Our deformed volume element in the neighborhood of the point of interest can then be seen to be

$$dV' = dx'_1 dx'_2 dx'_3 \approx (1 + e_{11})(1 + e_{22})(1 + e_{33})dx_1 dx_2 dx_3 \quad (2.29)$$

$$dV' \approx (1 + e_{11} + e_{22} + e_{33})dV. \quad (2.30)$$

Reverting again to summation convention, this is

$$dV' \approx (1 + e_{ii})dV. \quad (2.31)$$

This allows us to give a physical interpretation to the trace of the strain tensor, so that in a small enough neighborhood we have

$$e_{kk} = \frac{dV' - dV}{dV}. \quad (2.32)$$

The trace of the strain tensor quantifies the relative difference between the deformed volume element and the original volume element.

2.3 STRAIN IN CYLINDRICAL COORDINATES.

Useful in many practice problems are the cylindrical coordinate representation of the strain tensor

$$2e_{rr} = \frac{\partial u_r}{\partial r} \quad (2.33)$$

$$2e_{\phi\phi} = \frac{1}{r} \frac{\partial u_\phi}{\partial \phi} + \frac{1}{r} u_r \quad (2.34)$$

$$2e_{zz} = \frac{\partial u_z}{\partial z} \quad (2.35)$$

$$2e_{zr} = \frac{\partial u_r}{\partial z} + \frac{\partial u_z}{\partial r} \quad (2.36)$$

$$2e_{r\phi} = \frac{\partial u_\phi}{\partial r} - \frac{1}{r} u_\phi + \frac{1}{r} \frac{\partial u_r}{\partial \phi} \quad (2.37)$$

$$2e_{\phi z} = \frac{\partial u_\phi}{\partial z} + \frac{1}{r} \frac{\partial u_z}{\partial \phi}. \quad (2.38)$$

This result can be found in [13], and is derived in appendix A using the second order methods found above for the Cartesian tensor.

An easier way to do this derivation (and understand what the coordinates represent) follows from the relation found in §6 of [2]

$$2\mathbf{e}_i e_{ij} \mathbf{e}_j \cdot \hat{\mathbf{n}} = 2(\hat{\mathbf{n}} \cdot \nabla) \mathbf{u} + \hat{\mathbf{n}} \times (\nabla \times \mathbf{u}), \quad (2.39)$$

where $\hat{\mathbf{n}}$ is the normal to the surface at which we are measuring a force applied to the solid (our Cauchy tetrahedron).

The cylindrical tensor coordinates of eq. (2.33) follow from eq. (2.39) nicely taking $\hat{\mathbf{n}} = \hat{\mathbf{r}}, \hat{\boldsymbol{\phi}}, \hat{\mathbf{z}}$ in turn. This derivation can be found in appendix B.

2.4 COMPATIBILITY CONDITION FOR 2D STRAIN.

$$e_{ij} = \begin{bmatrix} e_{11} & e_{12} \\ e_{21} & e_{22} \end{bmatrix}. \quad (2.40)$$

From eq. (2.14) we see that we have

$$\begin{aligned} e_{11} &= \frac{\partial e_1}{\partial x_1} \\ e_{22} &= \frac{\partial e_2}{\partial x_2} \\ e_{12} = e_{21} &= \frac{1}{2} \left(\frac{\partial e_2}{\partial x_1} + \frac{\partial e_1}{\partial x_2} \right). \end{aligned} \quad (2.41)$$

We have a relationship between these displacements (called the compatibility relationship), which is

$$\boxed{\frac{\partial^2 e_{11}}{\partial x_2^2} + \frac{\partial^2 e_{22}}{\partial x_1^2} = 2 \frac{\partial^2 e_{12}}{\partial x_1 \partial x_2}.} \quad (2.42)$$

We find this by straight computation

$$\begin{aligned} \frac{\partial^2 e_{11}}{\partial x_2^2} &= \frac{\partial^2}{\partial x_2^2} \left(\frac{\partial e_1}{\partial x_1} \right) \\ &= \frac{\partial^3 e_1}{\partial x_1 \partial x_2^2}, \end{aligned} \quad (2.43)$$

and

$$\begin{aligned} \frac{\partial^2 e_{22}}{\partial x_1^2} &= \frac{\partial^2}{\partial x_1^2} \left(\frac{\partial e_2}{\partial x_2} \right) \\ &= \frac{\partial^3 e_2}{\partial x_2 \partial x_1^2}. \end{aligned} \quad (2.44)$$

Now, looking at the cross term we find

$$\begin{aligned} 2 \frac{\partial^2 e_{12}}{\partial x_1 \partial x_2} &= \frac{\partial^2 e_{12}}{\partial x_1 \partial x_2} \left(\frac{\partial e_2}{\partial x_1} + \frac{\partial e_1}{\partial x_2} \right) \\ &= \left(\frac{\partial^3 e_1}{\partial x_1 \partial x_2^2} + \frac{\partial^3 e_2}{\partial x_2 \partial x_1^2} \right). \end{aligned} \quad (2.45)$$

We have found an interrelationship between the components of the strain

$$\boxed{2 \frac{\partial^2 e_{12}}{\partial x_1 \partial x_2} = \frac{\partial^2 e_{22}}{\partial x_1^2} + \frac{\partial^2 e_{11}}{\partial x_2^2}.} \quad (2.46)$$

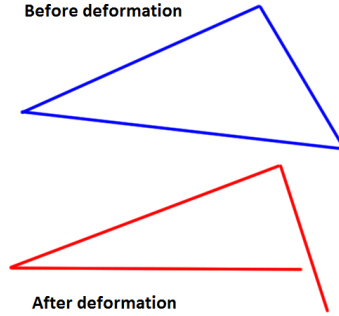

Figure 2.3: Disjoint deformation illustrated.

This relationship is called the *compatibility condition*, and ensures that we do not have a disjoint deformation of the form in fig. 2.3. I went looking for something to substantiate the claim that the compatibility condition eq. (2.46) is what is required to ensure a deformation maintained a coherent solid geometry. I was not able to find any references to this compatibility condition in any of the texts I have, but found [17], [28], and [20]. It is not terribly surprising to see Christoffel symbol and differential forms references on those pages, since one can imagine that we would wish to look at the mappings of all the points in the object as it undergoes the transformation from the original to the deformed state.

Even with just three points in a plane, say \mathbf{a} , \mathbf{b} , \mathbf{c} , the general deformation of an object does not seem like it is the easiest thing to describe. We can imagine that these have trajectories in the deformation process $\mathbf{a} = \mathbf{a}(\alpha)$, $\mathbf{b} = \mathbf{b}(\beta)$, $\mathbf{c} = \mathbf{c}(\gamma)$, with \mathbf{a}' , \mathbf{b}' , \mathbf{c}' at the end points of the trajectories. We would want to look at displacement vectors \mathbf{u}_a , \mathbf{u}_b , \mathbf{u}_c along each of these trajectories, and then see how they must be related. Doing that carefully must result in this compatibility condition.

2.5 COMPATIBILITY CONDITION FOR 3D STRAIN.

While we have 9 components in the tensor, not all of these are independent. The sets above and below the diagonal can be re-

lated. It can be shown that there are 6 relationships between the components of the general three dimensional strain tensor e_{ij} .

2.6 ON THE FACTOR OF TWO IN THE TENSOR DEFINITION.

Why do we have a factor two in the strain tensor definition? Observe that if the deformation is small we can write

$$\begin{aligned} dl'^2 - dl^2 &= (dl' - dl)(dl' + dl) \\ &\approx (dl' - dl)2dl, \end{aligned} \quad (2.47)$$

so that we find

$$\frac{dl'^2 - dl^2}{dl^2} \approx \frac{dl' - dl}{dl}. \quad (2.48)$$

Suppose for example, that we have a diagonalized strain tensor, then we find

$$dl'^2 - dl^2 = 2e_{ii} \left(\frac{dx_i}{dl} \right)^2, \quad (2.49)$$

so that

$$\frac{dl'^2 - dl^2}{dl^2} = 2e_{ii} dx_i^2. \quad (2.50)$$

Observe that here again we see this factor of two.

If we have a diagonalized strain tensor, the tensor is of the form

$$\begin{bmatrix} e_{11} & 0 & 0 \\ 0 & e_{22} & 0 \\ 0 & 0 & e_{33} \end{bmatrix}, \quad (2.51)$$

so we have

$$dx_i'^2 - dx_i^2 = 2e_{ii} dx_i^2, \quad (2.52)$$

$$dl'^2 = (1 + 2e_{11})dx_1^2 + (1 + 2e_{22})dx_2^2 + (1 + 2e_{33})dx_3^2, \quad (2.53)$$

$$dl^2 = dx_1^2 + dx_2^2 + dx_3^2, \quad (2.54)$$

SO

$$\begin{aligned} dx'_1 &= \sqrt{1 + 2e_{11}}dx_1 \sim (1 + e_{11})dx_1 \\ dx'_2 &= \sqrt{1 + 2e_{22}}dx_2 \sim (1 + e_{22})dx_2 \\ dx'_3 &= \sqrt{1 + 2e_{33}}dx_3 \sim (1 + e_{33})dx_3. \end{aligned} \quad (2.55)$$

Observe that the change in the volume element becomes the trace

$$dV' = dx'_1 dx'_2 dx'_3 = dV(1 + e_{ii}). \quad (2.56)$$

2.7 SUMMARY.

2.7.1 Strain Tensor.

Identifying a point in a solid with coordinates x_i and the coordinates of that portion of the solid after displacement, we formed the difference as a measure of the displacement

$$u_i = x'_i - x_i. \quad (2.57)$$

With $du_i = \partial u_i / \partial x_j dx_j$, we computed the difference in length (squared) for an element of the displaced solid and found

$$dx'_k dx'_k - dx_k dx_k = \left(\frac{\partial u_j}{\partial x_i} + \frac{\partial u_i}{\partial x_j} + \frac{\partial u_k}{\partial x_i} \frac{\partial u_k}{\partial x_j} \right) dx_i dx_j, \quad (2.58)$$

or defining the *strain tensor* e_{ij} , we have

$$(d\mathbf{x}')^2 - (d\mathbf{x})^2 = 2e_{ij}dx_i dx_j, \quad (2.59a)$$

$$e_{ij} = \frac{1}{2} \left(\frac{\partial u_j}{\partial x_i} + \frac{\partial u_i}{\partial x_j} + \frac{\partial u_k}{\partial x_i} \frac{\partial u_k}{\partial x_j} \right). \quad (2.59b)$$

In this course we use only the linear terms and write

$$e_{ij} = \frac{1}{2} \left(\frac{\partial u_j}{\partial x_i} + \frac{\partial u_i}{\partial x_j} \right). \quad (2.60)$$

2.7.2 *Diagonal strain representation.*

In a basis for which the strain tensor is diagonal, it was pointed out that we can write our difference in squared displacement as (for $k = 1, 2, 3$, no summation convention)

$$(dx'_k)^2 - (dx_k)^2 = 2e_{kk}dx_k dx_k, \quad (2.61)$$

from which we can rearrange, take roots, and apply a first order Taylor expansion to find (again no summation convention)

$$dx'_k \approx (1 + e_{kk})dx_k. \quad (2.62)$$

An approximation of the displaced volume was then found in terms of the strain tensor trace (summation convention back again)

$$dV' \approx (1 + e_{kk})dV, \quad (2.63)$$

allowing us to identify this trace as a relative difference in displaced volume

$$e_{kk} \approx \frac{dV' - dV}{dV}. \quad (2.64)$$

2.7.3 *Strain in cylindrical coordinates.*

Useful in many practice problems are the cylindrical coordinate representation of the strain tensor

$$\begin{aligned} 2e_{rr} &= \frac{\partial u_r}{\partial r} \\ 2e_{\phi\phi} &= \frac{1}{r} \frac{\partial u_\phi}{\partial \phi} + \frac{1}{r} u_r \\ 2e_{zz} &= \frac{\partial u_z}{\partial z} \\ 2e_{zr} &= \frac{\partial u_r}{\partial z} + \frac{\partial u_z}{\partial r} \\ 2e_{r\phi} &= \frac{\partial u_\phi}{\partial r} - \frac{1}{r} u_\phi + \frac{1}{r} \frac{\partial u_r}{\partial \phi} \\ 2e_{\phi z} &= \frac{\partial u_\phi}{\partial z} + \frac{1}{r} \frac{\partial u_z}{\partial \phi}. \end{aligned} \quad (2.65)$$

This can be found in [13]. It was not derived there or in class, but is not too hard, even using the second order methods we used for the Cartesian form of the tensor.

An easier way to do this derivation (and understand what the coordinates represent) follows from the relation found in §6 of [2]

$$2\mathbf{e}_i e_{ij} n_j = 2(\hat{\mathbf{n}} \cdot \nabla)\mathbf{u} + \hat{\mathbf{n}} \times (\nabla \times \mathbf{u}), \quad (2.66)$$

where $\hat{\mathbf{n}}$ is the normal to the surface at which we are measuring a force applied to the solid (our Cauchy tetrahedron).

The cylindrical tensor coordinates of eq. (2.65) follow from eq. (2.66) nicely taking $\hat{\mathbf{n}} = \hat{\mathbf{r}}, \hat{\boldsymbol{\phi}}, \hat{\mathbf{z}}$ in turn.

2.7.4 *Compatibility condition.*

For a 2D strain tensor we found an interrelationship between the components of the strain tensor

$$2 \frac{\partial^2 e_{12}}{\partial x_1 \partial x_2} = \frac{\partial^2 e_{22}}{\partial x_1^2} + \frac{\partial^2 e_{11}}{\partial x_2^2}, \quad (2.67)$$

and called this the compatibility condition. It was claimed, but not demonstrated that this is what is required to ensure a deformation maintained a coherent solid geometry.

I was not able to find any references to this compatibility condition in any of the texts I have, but found [17], [28], and [20]. It is not terribly surprising to see Christoffel symbol and differential forms references on those pages, since one can imagine that we would wish to look at the mappings of all the points in the object as it undergoes the transformation from the original to the deformed state.

Even with just three points in a plane, say $\mathbf{a}, \mathbf{b}, \mathbf{c}$, the general deformation of an object does not seem like it is the easiest thing to describe. We can imagine that these have trajectories in the deformation process $\mathbf{a} = \mathbf{a}(\alpha), \mathbf{b} = \mathbf{b}(\beta), \mathbf{c} = \mathbf{c}(\gamma)$, with $\mathbf{a}', \mathbf{b}', \mathbf{c}'$ at the end points of the trajectories. We would want to look at displacement vectors $\mathbf{u}_a, \mathbf{u}_b, \mathbf{u}_c$ along each of these trajectories, and then see how they must be related. Doing that carefully must result in this compatibility condition.

2.8 PROBLEMS.

Exercise 2.1 Strain tensor, small displacement. (2012 ps1, p2 a)

Small displacement field in a material is given by

$$\begin{aligned} e_1 &= 2x_1x_2 \\ e_2 &= x_3^2 \\ e_3 &= x_1^2 - x_3. \end{aligned} \tag{2.68}$$

Find

- Infinitesimal strain tensor e_{ij} .
- Principal strains and axes at $(x_1, x_2, x_3) = (1, 2, 4)$.

Exercise 2.2 Computing stretch in any given direction.

In class, it was stated “How do we use the strain tensor? Strain is the measure of stretching, so given a strain tensor, we should be able to compute the stretch in any given direction.”

Exercise 2.3 Derive the 3D compatibility conditions.

PLACEHOLDER. We would be promised some homework for this, presumably with hints that walked us through the complexity of the proof, but that never materialized.

Answer for Exercise 2.1

Solution Part a. *For the infinitesimal strain tensor e_{ij} , we have*

$$\begin{aligned} e_{11} &= \frac{\partial e_1}{\partial x_1} \\ &= \frac{\partial}{\partial x_1} 2x_1x_2 \\ &= 2x_2 \end{aligned} \tag{2.69}$$

$$\begin{aligned} e_{22} &= \frac{\partial e_2}{\partial x_2} \\ &= \frac{\partial}{\partial x_2} x_3^2 \\ &= 0 \end{aligned} \tag{2.70}$$

$$\begin{aligned}
 e_{33} &= \frac{\partial e_3}{\partial x_3} \\
 &= \frac{\partial}{\partial x_3} (x_1^2 - x_3) \\
 &= -1
 \end{aligned} \tag{2.71}$$

$$\begin{aligned}
 e_{12} &= \frac{1}{2} \left(\frac{\partial e_2}{\partial x_1} + \frac{\partial e_1}{\partial x_2} \right) \\
 &= \frac{1}{2} \left(\frac{\partial}{\partial x_1} x_3^2 + \frac{\partial}{\partial x_2} 2x_1x_2 \right) \\
 &= x_1
 \end{aligned} \tag{2.72}$$

$$\begin{aligned}
 e_{23} &= \frac{1}{2} \left(\frac{\partial e_3}{\partial x_2} + \frac{\partial e_2}{\partial x_3} \right) \\
 &= \frac{1}{2} \left(\frac{\partial}{\partial x_2} (x_1^2 - x_3) + \frac{\partial}{\partial x_3} x_3^2 \right) \\
 &= x_3
 \end{aligned} \tag{2.73}$$

$$\begin{aligned}
 e_{31} &= \frac{1}{2} \left(\frac{\partial e_1}{\partial x_3} + \frac{\partial e_3}{\partial x_1} \right) \\
 &= \frac{1}{2} \left(\frac{\partial}{\partial x_3} 2x_1x_2 + \frac{\partial}{\partial x_1} (x_1^2 - x_3) \right) \\
 &= x_1.
 \end{aligned} \tag{2.74}$$

In matrix form we have

$$\mathbf{e} = \begin{bmatrix} 2x_2 & x_1 & x_1 \\ x_1 & 0 & x_3 \\ x_1 & x_3 & -1 \end{bmatrix}. \tag{2.75}$$

Solution Part b. *For the principle strains and axes.* At the point (1, 2, 4) the strain tensor has the value

$$\mathbf{e} = \begin{bmatrix} 4 & 1 & 1 \\ 1 & 0 & 4 \\ 1 & 4 & -1 \end{bmatrix}. \tag{2.76}$$

We wish to diagonalize this, solving the characteristic equation for the eigenvalues λ

$$\begin{aligned}
 0 &= \begin{vmatrix} 4 - \lambda & 1 & 1 \\ 1 & -\lambda & 4 \\ 1 & 4 & -1 - \lambda \end{vmatrix} \\
 &= (4 - \lambda) \begin{vmatrix} -\lambda & 4 \\ 4 & -1 - \lambda \end{vmatrix} - \begin{vmatrix} 1 & 1 \\ 4 & -1 - \lambda \end{vmatrix} + \begin{vmatrix} 1 & 1 \\ -\lambda & 4 \end{vmatrix} \\
 &= (4 - \lambda)(\lambda^2 + \lambda - 16) - (-1 - \lambda - 4) + (4 + \lambda).
 \end{aligned} \tag{2.77}$$

We find the characteristic equation to be

$$0 = -\lambda^3 + 3\lambda^2 + 22\lambda - 55. \tag{2.78}$$

This does not appear to lend itself easily to manual solution (there are no obvious roots to factor out). As expected, since the matrix is symmetric, a plot [fig. 2.4](#) shows that all our roots are real. Numerically, we determine these roots to be

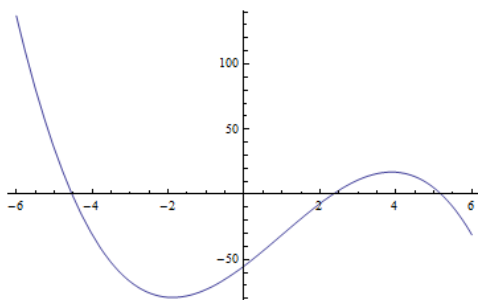

Figure 2.4: Q2. Characteristic equation.

$$\{5.19684, -4.53206, 2.33522\}, \tag{2.79}$$

with the corresponding basis (orthonormal eigenvectors), the principle axes are

$$\{\hat{\mathbf{p}}_1, \hat{\mathbf{p}}_2, \hat{\mathbf{p}}_3\} = \left\{ \begin{bmatrix} 0.76291 \\ 0.480082 \\ 0.433001 \end{bmatrix}, \begin{bmatrix} -0.010606 \\ -0.660372 \\ 0.750863 \end{bmatrix}, \begin{bmatrix} -0.646418 \\ 0.577433 \\ 0.498713 \end{bmatrix} \right\}. \tag{2.80}$$

Exercise 2.4 Constitutive relation. (2012 midterm, p1 b)

In continuum mechanics what is meant by the *constitutive relation*?

Answer for Exercise 2.4

The constitutive relation is the stress-strain relation, generally

$$\sigma_{ij} = c_{abij}e_{ab}, \quad (2.81)$$

which for isotropic solids we model as

$$\sigma_{ij} = \lambda e_{kk}\delta_{ij} + 2\mu e_{ij}, \quad (2.82)$$

and for Newtonian fluids

$$\sigma_{ij} = -p\delta_{ij} + 2\mu e_{ij}. \quad (2.83)$$

STRESS TENSOR.

3.1 FORCE PER UNIT VOLUME.

Reading for this section is §2 from [13].

We would like to consider a macroscopic model that contains the net effects of all the internal forces in the object as depicted in fig. 3.1 We will consider a volume big enough that we will not have

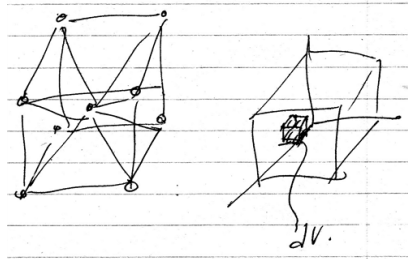

Figure 3.1: Internal forces.

to consider the individual atomic interactions, only the average effects of those interactions. Will look at the force per unit volume on a differential volume element. The total force on the body is

$$\iiint \mathbf{F} dV, \quad (3.1)$$

where \mathbf{F} is the force per unit volume. We will evaluate this by utilizing the divergence theorem. Recall that this was

$$\iiint (\nabla \cdot \mathbf{A}) dV = \iint \mathbf{A} \cdot d\mathbf{s}. \quad (3.2)$$

We have a small problem, since we have a non-divergence expression of the force here, and it is not immediately obvious that we can apply the divergence theorem. We can deal with this by assuming that we can find a vector valued tensor, so that if we take the

divergence of this tensor, we end up with the force. We introduce the vector valued quantity

$$\mathbf{F} = \mathbf{e}_i \frac{\partial \sigma_{ik}}{\partial x_k}, \quad (3.3)$$

and then apply the divergence theorem

$$\iiint \mathbf{F} dV = \iiint \mathbf{e}_i \frac{\partial \sigma_{ik}}{\partial x_k} dx^3 = \iint \mathbf{e}_i \sigma_{ik} ds_k, \quad (3.4)$$

where ds_k is a surface element. We identify this tensor

$$\sigma_{ik} = \frac{\text{Force} \cdot \mathbf{e}_i}{\text{Unit Area}}, \quad (3.5)$$

often writing it in matrix form

$$\begin{bmatrix} \sigma_{11} & \sigma_{12} & \sigma_{13} \\ \sigma_{21} & \sigma_{22} & \sigma_{23} \\ \sigma_{31} & \sigma_{32} & \sigma_{33} \end{bmatrix}. \quad (3.6)$$

So, starting with a desire to quantify the force per unit area acting on a body by expressing the components of that force as a set of divergence relations

$$f_i = \frac{\partial \sigma_{ik}}{\partial x_k}, \quad (3.7)$$

we find that the total force acting on the surface is given by the matrix product of the stress with the triplet of surface area elements

$$f_i = \sigma_{ik} ds_k, \quad (3.8)$$

as the force on the surface element ds_k . We have yet to find how the stress tensor can be related to deformations (via strain) and physical parameters such as pressure and the modulus of elasticity.

Unlike the strain, we do not have any expectation that this tensor is symmetric, and identify the diagonal components (no sum) σ_{ii} as quantifying the amount of compressive or contractive force per unit area, whereas the cross terms of the stress tensor introduce shearing deformations in the solid. Let us attempt to get a feel for this graphically.

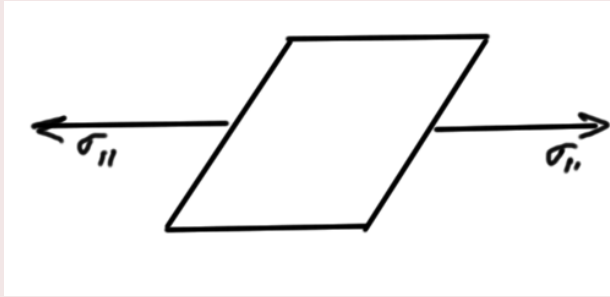
Example 3.1: Stretch, 2 opposing directions.**Figure 3.2: Opposing stresses in one direction.**

Here, as illustrated in fig. 3.2, the associated (2D) stress tensor takes the simple form

$$\begin{bmatrix} \sigma_{11} & 0 \\ 0 & 0 \end{bmatrix}. \quad (3.9)$$

This is called uniaxial stress.

Example 3.2: Stretch, mutually perpendicular directions.

For a pair of perpendicular forces applied in two dimensions, as illustrated in fig. 3.3

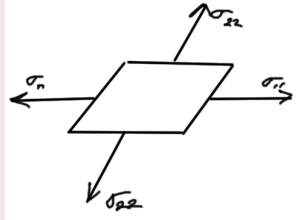

Figure 3.3: Mutually perpendicular forces.

our stress tensor now just takes the form

$$\begin{bmatrix} \sigma_{11} & 0 \\ 0 & \sigma_{22} \end{bmatrix}. \quad (3.10)$$

This is called biaxial stress.

It is easy to imagine now how to get some more general stress tensors, should we make a change of basis that rotates our frame.

Example 3.3: Radial stretch.

Suppose we have a fire fighter's safety net, used to catch somebody jumping from a burning building (do they ever do that outside of movies?), as in fig. 3.4. Each of the firefighters contributes to the stretch.

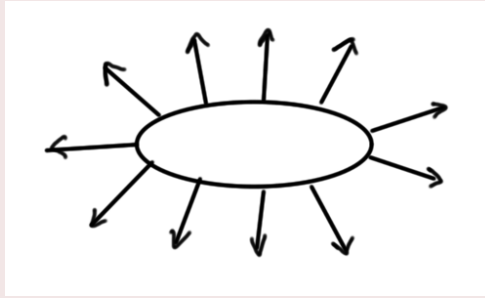

Figure 3.4: Radial forces.

3.2 STRESS TENSOR IN 2D.

In two dimensions this is illustrated in fig. 3.5. Observe that we use

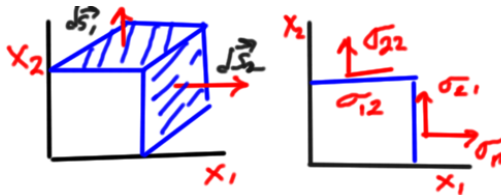

Figure 3.5: 2D stress tensor.

the index i above as the direction of the force, and index k as the direction normal to the surface.

We will show later that this tensor is in fact symmetric. The stress tensor σ_{ij} is a second rank tensor, with the first index i

defining the direction of the force, and the second index j defining the surface.

Observe that the dimensions of σ_{ij} is force per unit area, just like pressure. We will in fact show that this tensor is akin to the pressure, and the diagonalized components of this tensor represent the pressure.

We have illustrated the stress tensor in a couple of 2D examples. The first we call uniaxial stress, having just the 1, 1 element of the matrix as illustrated in fig. 3.2.

$$\sigma = \begin{bmatrix} \sigma_{11} & 0 \\ 0 & 0 \end{bmatrix}. \quad (3.11)$$

A biaxial stress is illustrated in fig. 3.3. where for $\sigma_{11} \neq \sigma_{22}$ our tensor takes the form

$$\sigma = \begin{bmatrix} \sigma_{11} & 0 \\ 0 & \sigma_{22} \end{bmatrix}. \quad (3.12)$$

In the general case we have

$$\sigma = \begin{bmatrix} \sigma_{11} & \sigma_{12} \\ \sigma_{21} & \sigma_{22} \end{bmatrix}. \quad (3.13)$$

We can attempt to illustrate this, but it becomes much harder to visualize as shown in fig. 3.6 In equilibrium we must have

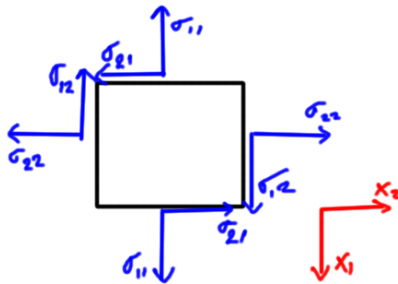

Figure 3.6: General stress.

$$\sigma_{12} = \sigma_{21}. \quad (3.14)$$

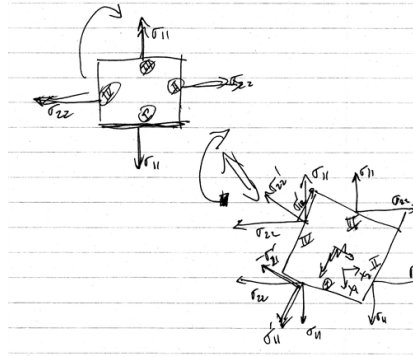

Figure 3.7: Area element under stress with and without rotation.

We can use similar arguments to show that the stress tensor is symmetric. We will look at the two dimensional case in some detail, as in fig. 3.7 Under this coordinate transformation, a rotation, the diagonal stress tensor is taken to a non-diagonal form

$$\begin{bmatrix} \sigma_{11} & 0 \\ 0 & \sigma_{22} \end{bmatrix} \leftrightarrow \begin{bmatrix} \sigma'_{11} & \sigma'_{12} \\ \sigma'_{21} & \sigma'_{22} \end{bmatrix}. \tag{3.15}$$

3.3 STRESS TENSOR IN 3D.

In 3D we have three components of the stress tensor acting on each surface, as illustrated in fig. 3.8 We have three unique surface

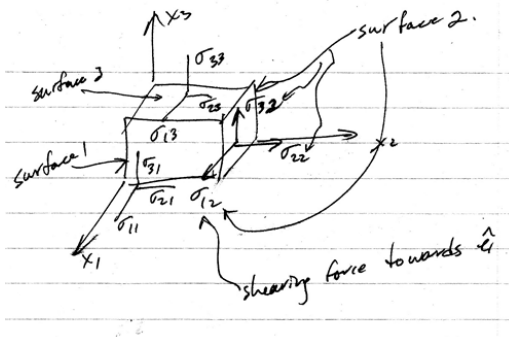

Figure 3.8: Strain components on a 3D volume.

orientations and three components of the force for each of these,

resulting in nine components, but these are not all independent. For an object in equilibrium we must have $\sigma_{ij} = \sigma_{ji}$. Explicitly, that is

$$\sigma_{12} = \sigma_{21}, \tag{3.16}$$

$$\sigma_{23} = \sigma_{32}, \tag{3.17}$$

$$\sigma_{31} = \sigma_{13}. \tag{3.18}$$

3.4 CAUCHY TETRAHEDRON.

To examine the question of how the stress tensor and the force relate, we project the force onto a planar surface. This is called the Cauchy tetrahedron as in fig. 3.9

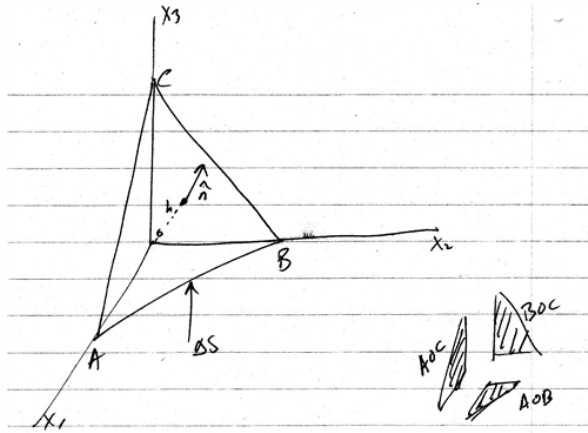

Figure 3.9: Cauchy tetrahedron.

$$\mathbf{f} = \frac{\text{external force}}{\text{unit area}} = f_j \mathbf{e}_j, \tag{3.19}$$

or

internal stress = external force.

We write \hat{n} in terms of the direction cosines

$$\hat{n} = n_1 \mathbf{e}_1 + n_2 \mathbf{e}_2 + n_3 \mathbf{e}_3. \tag{3.20}$$

Here

$$n_1 = \hat{\mathbf{n}} \cdot \mathbf{e}_1 \quad (3.21)$$

$$n_2 = \hat{\mathbf{n}} \cdot \mathbf{e}_2 \quad (3.22)$$

$$n_3 = \hat{\mathbf{n}} \cdot \mathbf{e}_3, \quad (3.23)$$

or

$$n_j = \hat{\mathbf{n}} \cdot \mathbf{e}_j = \cos \phi_j. \quad (3.24)$$

This is illustrated in fig. 3.10. Performing a force balance on x_1

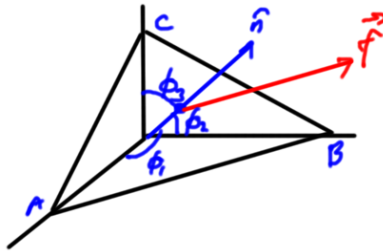

Figure 3.10: Cauchy tetrahedron direction cosines.

direction, where we match total external force in each direction to the total internal force (σ'_{ij} 's) as follows

$$\begin{aligned} f_1 \times \text{area ABC} &= \sigma_{11} \times \text{area BOC} \\ &+ \sigma_{12} \times \text{area AOC} \\ &+ \sigma_{13} \times \text{area AOB}. \end{aligned} \quad (3.25)$$

Similarly

$$\begin{aligned} f_2 \times \text{area ABC} &= \sigma_{21} \times \text{area BOC} \\ &+ \sigma_{22} \times \text{area AOC} \\ &+ \sigma_{23} \times \text{area AOB}, \end{aligned} \quad (3.26)$$

and

$$\begin{aligned} f_3 \times \text{area ABC} &= \sigma_{31} \times \text{area BOC} \\ &+ \sigma_{32} \times \text{area AOC} \\ &+ \sigma_{33} \times \text{area AOB}. \end{aligned} \quad (3.27)$$

We can therefore write these force components like

$$f_1 = \sigma_{11} \frac{BOC}{ABC} + \sigma_{12} \frac{AOC}{ABC} + \sigma_{13} \frac{AOB}{ABC} \quad (3.28)$$

but these ratios are really just the projections of the areas as illustrated in fig. 3.11 where an arbitrary surface with area ΔS can be

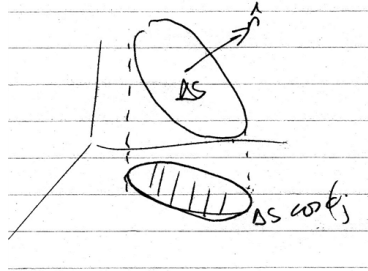

Figure 3.11: Area projection.

decomposed into projections

$$\Delta S \cos \phi_j, \quad (3.29)$$

utilizing the direction cosines. We can therefore write

$$f_1 = \sigma_{11}n_1 + \sigma_{12}n_2 + \sigma_{13}n_3 \quad (3.30)$$

$$f_2 = \sigma_{21}n_1 + \sigma_{22}n_2 + \sigma_{23}n_3 \quad (3.31)$$

$$f_3 = \sigma_{31}n_1 + \sigma_{32}n_2 + \sigma_{33}n_3, \quad (3.32)$$

or in matrix notation

$$\begin{bmatrix} f_1 \\ f_2 \\ f_3 \end{bmatrix} = \begin{bmatrix} \sigma_{11} & \sigma_{12} & \sigma_{13} \\ \sigma_{21} & \sigma_{22} & \sigma_{23} \\ \sigma_{31} & \sigma_{32} & \sigma_{33} \end{bmatrix} \begin{bmatrix} n_1 \\ n_2 \\ n_3 \end{bmatrix}. \quad (3.33)$$

This is just

$$f_i = \sigma_{ij}n_j. \quad (3.34)$$

This force with components f_i is also called the traction vector

$$\tau_i = \sigma_{ij}n_j. \quad (3.35)$$

In matrix form the traction vector is

$$\boldsymbol{\tau} = \boldsymbol{\sigma} \cdot \hat{\mathbf{n}} = \begin{bmatrix} \sigma_{11} & \sigma_{12} & \sigma_{13} \\ \sigma_{21} & \sigma_{22} & \sigma_{23} \\ \sigma_{31} & \sigma_{32} & \sigma_{33} \end{bmatrix} \begin{bmatrix} n_1 \\ n_2 \\ n_3 \end{bmatrix}. \quad (3.36)$$

3.5 CONSTITUTIVE RELATION.

Reading: §2, §4 and §5 from the text [13].

We can find the relationship between stress and strain, both analytically and experimentally, and call this the Constitutive relation. We prefer to deal with ranges of distortion that are small enough that we can make a linear approximation for this relation. In general such a linear relationship takes the form

$$\sigma_{ij} = c_{ijkl}e_{kl}. \quad (3.37)$$

Materials for which the stress and strain tensors are linearly related are called Newtonian. We will not consider any non-Newtonian materials in this course.

Consider the number of components that we are talking about for various rank tensors

$$\begin{aligned} 0^{\text{th}} \text{ rank tensor} & \quad 3^0 = 1 \text{ components,} \\ 1^{\text{st}} \text{ rank tensor} & \quad 3^1 = 3 \text{ components,} \\ 2^{\text{nd}} \text{ rank tensor} & \quad 3^2 = 9 \text{ components,} \\ 3^{\text{rd}} \text{ rank tensor} & \quad 3^3 = 81 \text{ components.} \end{aligned} \quad (3.38)$$

We have a lot of components, even for a linear relation between stress and strain. For isotropic materials we model the constitutive relation instead as

$$\sigma_{ij} = \lambda e_{kk} \delta_{ij} + 2\mu e_{ij}. \quad (3.39)$$

It can be shown [5] that a relationship between stress and strain of this form is actually required by isotropy.

For such a modeling of the material the (measured) values λ and μ (shear modulus or modulus of rigidity) are called the Lamé parameters.

It will be useful to compute the trace of the stress tensor in the form of the constitutive relation for the isotropic model. We find

$$\begin{aligned}\sigma_{ii} &= \lambda e_{kk} \delta_{ii} + 2\mu e_{ii} \\ &= 3\lambda e_{kk} + 2\mu e_{jj},\end{aligned}\tag{3.40}$$

or

$$\sigma_{ii} = (3\lambda + 2\mu)e_{kk}.\tag{3.41}$$

We can now also invert this, to find the trace of the strain tensor in terms of the stress tensor

$$e_{ii} = \frac{\sigma_{kk}}{3\lambda + 2\mu}.\tag{3.42}$$

Substituting back into our original relationship eq. (3.39), and find

$$\sigma_{ij} = \lambda \frac{\sigma_{kk}}{3\lambda + 2\mu} \delta_{ij} + 2\mu e_{ij},\tag{3.43}$$

which finally provides an inverted expression with the strain tensor expressed in terms of the stress tensor

$$2\mu e_{ij} = \sigma_{ij} - \lambda \frac{\sigma_{kk}}{3\lambda + 2\mu} \delta_{ij}.\tag{3.44}$$

3.6 CONSTITUTIVE RELATION, HYDROSTATIC COMPRESSION.

Hydrostatic compression is when we have no shear stress, only normal components of the stress matrix σ_{ij} is nonzero. Strictly speaking we define Hydrostatic compression as

$$\sigma_{ij} = -p\delta_{ij},\tag{3.45}$$

which is not only diagonal, but has all components of the stress tensor equal.

We can write the trace of the stress tensor as

$$\sigma_{ii} = -3p = (3\lambda + 2\mu)e_{kk}.\tag{3.46}$$

Now, from our discussion of the strain tensor e_{ij} recall that we found in the limit

$$dV' = (1 + e_{ii})dV,\tag{3.47}$$

allowing us to express the change in volume relative to the original volume in terms of the strain trace

$$e_{ii} = \frac{dV' - dV}{dV}. \quad (3.48)$$

Writing that relative volume difference as $\Delta V/V$ we find

$$-3p = (3\lambda + 2\mu) \frac{\Delta V}{V}, \quad (3.49)$$

or

$$-\frac{pV}{\Delta V} = \left(\lambda + \frac{2}{3}\mu \right) = K, \quad (3.50)$$

where K is called the Bulk modulus.

3.7 CONSTITUTIVE RELATION FOR UNIAXIAL STRESS.

Referring to fig. 3.2 and expanding out eq. (3.44) we have for the 1, 1 element of the strain tensor

$$\boldsymbol{\sigma} = \begin{bmatrix} \sigma_{11} & 0 & 0 \\ 0 & 0 & 0 \\ 0 & 0 & 0 \end{bmatrix}, \quad (3.51)$$

and

$$\begin{aligned} 2\mu e_{11} &= \sigma_{11} - \frac{\lambda(\sigma_{11} + \sigma_{22})}{3\lambda + 2\mu} \\ &= \sigma_{11} \frac{3\lambda + 2\mu - \lambda}{3\lambda + 2\mu} \\ &= 2\sigma_{11} \frac{\lambda + \mu}{3\lambda + 2\mu}, \end{aligned} \quad (3.52)$$

or

$$\frac{\sigma_{11}}{e_{11}} = \frac{\mu(3\lambda + 2\mu)}{\lambda + \mu} = E, \quad (3.53)$$

where E is Young's modulus. Young's modulus in the text (5.3) is given in terms of the bulk modulus K . Using $\lambda = K - 2\mu/3$ we find

$$\begin{aligned} E &= \frac{\mu(3\lambda + 2\mu)}{\lambda + \mu} \\ &= \frac{\mu(3(K - 2\mu/3) + 2\mu)}{K - 2\mu/3 + \mu} \\ &= \frac{3K\mu}{K + \mu/3}. \end{aligned} \tag{3.54}$$

That is

$$E = \frac{\mu(3\lambda + 2\mu)}{\lambda + \mu} = \frac{9K\mu}{3K + \mu}. \tag{3.55}$$

We define Poisson's ratio ν as the quantity

$$\frac{e_{22}}{e_{11}} = \frac{e_{33}}{e_{11}} = -\nu. \tag{3.56}$$

Note that we are still talking about uniaxial stress here. Referring back to eq. (3.44) we have

$$\begin{aligned} 2\mu e_{22} &= \sigma_{22} - \lambda \frac{\sigma_{kk}}{3\lambda + 2\mu} \delta_{22} \\ &= \sigma_{22} - \lambda \frac{\sigma_{kk}}{3\lambda + 2\mu} \\ &= -\frac{\lambda \sigma_{11}}{3\lambda + 2\mu}. \end{aligned} \tag{3.57}$$

Recall eq. (3.53) that we had

$$\sigma_{11} = \frac{\mu(3\lambda + 2\mu)}{\lambda + \mu} e_{11}. \tag{3.58}$$

Inserting this gives us

$$2\mu e_{22} = -\frac{\lambda}{3\lambda + 2\mu} \frac{\mu(3\lambda + 2\mu)}{\lambda + \mu} e_{11}, \tag{3.59}$$

so

$$\nu = -\frac{e_{22}}{e_{11}} = \frac{\lambda}{2(\lambda + \mu)}. \tag{3.60}$$

We can also relate the Poisson's ratio ν to the shear modulus μ (see the appendix: C)

$$\mu = \frac{E}{2(1 + \nu)}, \quad (3.61)$$

$$\lambda = \frac{E\nu}{(1 - 2\nu)(1 + \nu)}, \quad (3.62)$$

$$\begin{aligned} e_{11} &= \frac{1}{E} (\sigma_{11} - \nu(\sigma_{22} + \sigma_{33})), \\ e_{22} &= \frac{1}{E} (\sigma_{22} - \nu(\sigma_{11} + \sigma_{33})), \\ e_{33} &= \frac{1}{E} (\sigma_{33} - \nu(\sigma_{11} + \sigma_{22})). \end{aligned} \quad (3.63)$$

These ones are (5.14) in the text, and are easy enough to verify (not done here).

3.8 SUMMARY.

3.8.1 *Stress tensor.*

We sought and found a representation of the force per unit area acting on a body by expressing the components of that force as a set of divergence relations

$$f_i = \partial_k \sigma_{ik}, \quad (3.64)$$

and call the associated tensor σ_{ij} the *stress*.

Unlike the strain, we do not have any expectation that this tensor is symmetric, and identify the diagonal components (no sum) σ_{ii} as quantifying the amount of compressive or contractive force per unit area, whereas the cross terms of the stress tensor introduce shearing deformations in the solid.

With force balance arguments (the Cauchy tetrahedron) we found that the force per unit area on the solid, for a surface with unit normal pointing into the solid, was

$$\boldsymbol{\tau} = \mathbf{e}_i \tau_i = \mathbf{e}_i \sigma_{ij} n_j. \quad (3.65)$$

3.8.2 *Constitutive relation.*

In the scope of this course we considered only Newtonian materials, those for which the stress and strain tensors are linearly related

$$\sigma_{ij} = c_{ijkl}e_{kl}, \quad (3.66)$$

and further restricted our attention to isotropic materials, which can be shown to have the form

$$\sigma_{ij} = \lambda e_{kk}\delta_{ij} + 2\mu e_{ij}, \quad (3.67)$$

where λ and μ are the Lamé parameters and μ is called the shear modulus (and viscosity in the context of fluids).

By computing the trace of the stress σ_{ii} we can invert this to find

$$2\mu e_{ij} = \sigma_{ij} - \frac{\lambda}{3\lambda + 2\mu} \sigma_{kk} \delta_{ij}. \quad (3.68)$$

3.8.3 *Uniform hydrostatic compression.*

With only normal components of the stress (no shear), and the stress having the same value in all directions, we find

$$\sigma_{ij} = (3\lambda + 2\mu)e_{ij}, \quad (3.69)$$

and identify this combination $-3\lambda - 2\mu$ as the pressure, linearly relating the stress and strain tensors

$$\sigma_{ij} = -pe_{ij}. \quad (3.70)$$

With $e_{ii} = (dV' - dV)/dV = \Delta V/V$, we formed the Bulk modulus K with the value

$$K = \left(\lambda + \frac{2\mu}{3} \right) = -\frac{pV}{\Delta V}. \quad (3.71)$$

3.8.4 *Uniaxial stress. Young's modulus. Poisson's ratio.*

For the special case with only one non-zero stress component (we used σ_{11}) we were able to compute Young's modulus E , the ratio between stress and strain in that direction

$$E = \frac{\sigma_{11}}{e_{11}} = \frac{\mu(3\lambda + 2\mu)}{\lambda + \mu} = \frac{3K\mu}{K + \mu/3}. \quad (3.72)$$

Just because only one component of the stress is non-zero, does not mean that we have no deformation in any other directions. Introducing Poisson's ratio ν in terms of the ratio of the strains relative to the strain in the direction of the force we write and then subsequently found

$$\nu = -\frac{e_{22}}{e_{11}} = -\frac{e_{33}}{e_{11}} = \frac{\lambda}{2(\lambda + \mu)}. \quad (3.73)$$

We were also able to find

We can also relate the Poisson's ratio ν to the shear modulus μ

$$\mu = \frac{E}{2(1 + \nu)}, \quad (3.74)$$

$$\lambda = \frac{E\nu}{(1 - 2\nu)(1 + \nu)}. \quad (3.75)$$

$$e_{11} = \frac{1}{E} (\sigma_{11} - \nu(\sigma_{22} + \sigma_{33})), \quad (3.76)$$

$$e_{22} = \frac{1}{E} (\sigma_{22} - \nu(\sigma_{11} + \sigma_{33})), \quad (3.77)$$

$$e_{33} = \frac{1}{E} (\sigma_{33} - \nu(\sigma_{11} + \sigma_{22})). \quad (3.78)$$

3.9 PROBLEMS.

Exercise 3.1 Strain tensor from stress tensor. (2012 ps1, p1)

For the stress tensor

$$\sigma = \begin{bmatrix} 6 & 0 & 2 \\ 0 & 1 & 1 \\ 2 & 1 & 3 \end{bmatrix} \text{ M Pa.} \quad (3.79)$$

Find the corresponding strain tensor, assuming an isotropic solid with Young's modulus $E = 200 \times 10^9 \text{ N/m}^2$ and Poisson's ration $\nu = 0.35$.

Answer for Exercise 3.1

We need to express the relation between stress and strain in terms of Young's modulus and Poisson's ratio. In terms of Lamé parameters our model for the relations between stress and strain for an isotropic solid was given as

$$\sigma_{ij} = \lambda e_{kk} \delta_{ij} + 2\mu e_{ij}. \quad (3.80)$$

Computing the trace

$$\sigma_{kk} = (3\lambda + 2\mu)e_{kk}, \quad (3.81)$$

allows us to invert the relationship

$$2\mu e_{ij} = \sigma_{ij} - \lambda \frac{\sigma_{kk}}{3\lambda + 2\mu} \delta_{ij}. \quad (3.82)$$

In terms of Poisson's ratio ν and Young's modulus E , our Lamé parameters were found to be

$$\begin{aligned} \lambda &= \frac{Ev}{(1-2\nu)(1+\nu)} \\ \mu &= \frac{E}{2(1+\nu)}, \end{aligned} \quad (3.83)$$

and

$$\begin{aligned} 3\lambda + 2\mu &= \frac{3Ev}{(1-2\nu)(1+\nu)} + \frac{E}{1+\nu} \\ &= \frac{E}{1+\nu} \left(\frac{3\nu}{1-2\nu} + 1 \right) \\ &= \frac{E}{1+\nu} \frac{1+\nu}{1-2\nu} \\ &= \frac{E}{1-2\nu}. \end{aligned} \quad (3.84)$$

Our stress strain model for the relationship for an isotropic solid becomes

$$\begin{aligned} \frac{E}{1+\nu} e_{ij} &= \sigma_{ij} - \frac{Ev}{(1-2\nu)(1+\nu)} \frac{1-2\nu}{E} \sigma_{kk} \delta_{ij} \\ &= \sigma_{ij} - \frac{\nu}{1+\nu} \sigma_{kk} \delta_{ij}, \end{aligned} \quad (3.85)$$

or

$$e_{ij} = \frac{1}{E} \left((1 + \nu)\sigma_{ij} - \nu\sigma_{kk}\delta_{ij} \right). \quad (3.86)$$

As a sanity check note that this matches (5.12) of [13], although they use a notation of σ instead of ν for Poisson's ratio. We are now ready to tackle the problem. First we need the trace of the stress tensor

$$\sigma_{kk} = (6 + 1 + 3)\text{M Pa} = 10\text{M Pa}, \quad (3.87)$$

$$\begin{aligned} e_{ij} &= \frac{1}{E} \left((1 + \nu) \begin{bmatrix} 6 & 0 & 2 \\ 0 & 1 & 1 \\ 2 & 1 & 3 \end{bmatrix} - 10\nu \begin{bmatrix} 1 & 0 & 0 \\ 0 & 1 & 0 \\ 0 & 0 & 1 \end{bmatrix} \right) \text{M Pa} \\ &= \frac{1}{E} \left(\begin{bmatrix} 6 & 0 & 2 \\ 0 & 1 & 1 \\ 2 & 1 & 3 \end{bmatrix} + 0.35 \begin{bmatrix} -4 & 0 & 2 \\ 0 & -9 & 1 \\ 2 & 1 & -7 \end{bmatrix} \right) \text{M Pa} \quad (3.88) \\ &= \frac{1}{2 \times 10^5} \left(\begin{bmatrix} 6 & 0 & 2 \\ 0 & 1 & 1 \\ 2 & 1 & 3 \end{bmatrix} + 0.35 \begin{bmatrix} -4 & 0 & 2 \\ 0 & -9 & 1 \\ 2 & 1 & -7 \end{bmatrix} \right) \end{aligned}$$

Expanding out the last bits of arithmetic the strain tensor is found to have the form

$$e_{ij} = \begin{bmatrix} 23 & 0 & 13.5 \\ 0 & -10.75 & 6.75 \\ 13.5 & 6.75 & 2.75 \end{bmatrix} 10^{-6}. \quad (3.89)$$

Note that this is dimensionless, unlike the stress.

Associated Mathematica notebook for this problem ([continuumProblemSet1Q1.cdf](#))

Exercise 3.2 Small stress and strain. (2012 psi, p2 b)

For the problem 2.1, is the body under compression or expansion?

Answer for Exercise 3.2

To consider this question, suppose that as in the previous part, we determine a basis for which our strain tensor $e_{ij} = p_i \delta_{ij}$ is diagonal with respect to that basis at a given point \mathbf{x}_0 . We can then simplify the form of the stress tensor at that point in the object

$$\begin{aligned}\sigma_{ij} &= \frac{E}{1+\nu} \left(e_{ij} + \frac{\nu}{1-2\nu} e_{mm} \delta_{ij} \right) \\ &= \frac{E}{1+\nu} \left(p_i + \frac{\nu}{1-2\nu} e_{mm} \right) \delta_{ij}.\end{aligned}\tag{3.90}$$

We see that the stress tensor at this point is also necessarily diagonal if the strain is diagonal in that basis (with the implicit assumption here that we are talking about an isotropic material). Noting that the Poisson ratio is bounded according to

$$-1 \leq \nu \leq \frac{1}{2},\tag{3.91}$$

so if our trace is positive (as it is in this problem for all points $x_2 > 1/2$), then any positive principle strain value will result in a positive stress along that direction). For example at the point (1, 2, 4) of the previous part of this problem (for which $x_2 > 1/2$), we have

$$\sigma_{ij} = \frac{E}{1+\nu} \begin{bmatrix} 5.19684 + \frac{3\nu}{1-2\nu} & 0 & 0 \\ 0 & -4.53206 + \frac{3\nu}{1-2\nu} & 0 \\ 0 & 0 & 2.33522 + \frac{3\nu}{1-2\nu} \end{bmatrix}.\tag{3.92}$$

We see that at this point the (1, 1) and (3, 3) components of stress is positive (expansion in those directions) regardless of the material, and provided that

$$\frac{3\nu}{1-2\nu} > 4.53206,\tag{3.93}$$

(i.e. $\nu > 0.375664$) the material is under expansion in all directions. For $\nu < 0.375664$ the material at that point is expanding in the $\hat{\mathbf{p}}_1$ and $\hat{\mathbf{p}}_3$ directions, but under compression in the $\hat{\mathbf{p}}_2$ directions. For a visualization of this part of this problem see ([continuumProblem-Set1Q2animated.cdf](#)). This animates the stress tensor associated

with the problem, for different points (x, y, z) and values of Poisson's ratio ν , with Mathematica manipulate sliders available to alter these (as well as a zoom control to scale the graphic, keeping the orientation and scale fixed with any variation of the other parameters). This generalizes the solution of the problem (assuming I got it right for the specific $(1, 2, 4)$ point of the problem). The vectors are the orthonormal eigenvectors of the tensor, scaled by the magnitude of the eigenvectors of the stress tensor (also diagonal in the basis of the diagonalized strain tensor at the point in question). For those directions that are under expansive stress, I have colored the vectors blue, and for compressive directions, I have colored the vectors red.

A confirmation of the characteristic equation calculated manually is also available ([continuumProblemSet1Q2.cdf](#)).

Exercise 3.3 **Traction vector.** (2012 ps1, p3)

The stress tensor at a point has components given by

$$\sigma = \begin{bmatrix} 1 & -2 & 2 \\ -2 & 3 & 1 \\ 2 & 1 & -1 \end{bmatrix}. \quad (3.94)$$

Find the traction vector across an area normal to the unit vector

$$\hat{\mathbf{n}} = (\sqrt{2}\mathbf{e}_1 - \mathbf{e}_2 + \mathbf{e}_3)/2. \quad (3.95)$$

Can you construct a tangent vector $\boldsymbol{\tau}$ on this plane by inspection? What are the components of the force per unit area along the normal $\hat{\mathbf{n}}$ and tangent $\boldsymbol{\tau}$ on that surface? (hint: projection of the traction vector.)

Answer for Exercise 3.3

The traction vector, the force per unit volume that holds a body in equilibrium, in coordinate form was

$$P_i = \sigma_{ik}n_k, \quad (3.96)$$

where n_k was the coordinates of the normal to the surface with area df_k . In matrix form, this is just

$$\mathbf{P} = \sigma\hat{\mathbf{n}}, \quad (3.97)$$

so our traction vector for this stress tensor and surface normal is just

$$\begin{aligned}
 \mathbf{P} &= \frac{1}{2} \begin{bmatrix} 1 & -2 & 2 \\ -2 & 3 & 1 \\ 2 & 1 & -1 \end{bmatrix} \begin{bmatrix} \sqrt{2} \\ -1 \\ 1 \end{bmatrix} \\
 &= \frac{1}{2} \begin{bmatrix} \sqrt{2} + 2 + 2 \\ -2\sqrt{2} - 3 + 1 \\ 2\sqrt{2} - 1 - 1 \end{bmatrix} \\
 &= \begin{bmatrix} \sqrt{2}/2 + 2 \\ -\sqrt{2} - 1 \\ \sqrt{2} - 1 \end{bmatrix}.
 \end{aligned} \tag{3.98}$$

We also want a vector in the plane, and can pick

$$\boldsymbol{\tau} = \frac{1}{\sqrt{2}} \begin{bmatrix} 0 \\ 1 \\ 1 \end{bmatrix}, \tag{3.99}$$

or

$$\boldsymbol{\tau}' = \begin{bmatrix} \frac{1}{\sqrt{2}} \\ \frac{1}{2} \\ -\frac{1}{2} \end{bmatrix}. \tag{3.100}$$

It is clear that either of these is normal to $\hat{\mathbf{n}}$ (the first can also be computed by normalizing $\hat{\mathbf{n}} \times \mathbf{e}_1$, and the second with one round of Gram-Schmidt). However, neither of these vectors in the plane are particularly interesting since they are completely arbitrary. Let

us instead compute the projection and rejection of the traction vector with respect to the normal. We find for the projection

$$\begin{aligned}
 (\mathbf{P} \cdot \hat{\mathbf{n}})\hat{\mathbf{n}} &= \frac{1}{4} \left(\begin{bmatrix} \sqrt{2}/2 + 2 \\ -\sqrt{2} - 1 \\ \sqrt{2} - 1 \end{bmatrix} \cdot \begin{bmatrix} \sqrt{2} \\ -1 \\ 1 \end{bmatrix} \right) \begin{bmatrix} \sqrt{2} \\ -1 \\ 1 \end{bmatrix} \\
 &= \frac{1}{4} (1 + 2\sqrt{2} + \sqrt{2} + 1 + \sqrt{2} - 1) \begin{bmatrix} \sqrt{2} \\ -1 \\ 1 \end{bmatrix} \\
 &= \frac{1}{2} (1 + 4\sqrt{2}) \hat{\mathbf{n}}.
 \end{aligned} \tag{3.101}$$

Our rejection, the component of the traction vector in the plane, is

$$\begin{aligned}
 (\mathbf{P} \wedge \hat{\mathbf{n}})\hat{\mathbf{n}} &= \mathbf{P} - (\mathbf{P} \cdot \hat{\mathbf{n}})\hat{\mathbf{n}} \\
 &= \frac{1}{2} \begin{bmatrix} \sqrt{2}/2 + 2 \\ -\sqrt{2} - 1 \\ \sqrt{2} - 1 \end{bmatrix} - \frac{1}{4}(1 + r\sqrt{2}) \begin{bmatrix} \sqrt{2} \\ -1 \\ 1 \end{bmatrix} \\
 &= \frac{1}{4} \begin{bmatrix} \sqrt{2} \\ -3 \\ -5 \end{bmatrix}.
 \end{aligned} \tag{3.102}$$

This gives us a another vector perpendicular to the normal $\hat{\mathbf{n}}$

$$\hat{\boldsymbol{\tau}} = \frac{1}{6} \begin{bmatrix} \sqrt{2} \\ -3 \\ -5 \end{bmatrix}. \tag{3.103}$$

Wrapping up, we find the decomposition of the traction vector in the direction of the normal and its projection onto the plane to be

$$\mathbf{P} = \frac{1}{2}(1 + 4\sqrt{2})\hat{\mathbf{n}} + \frac{3}{2}\hat{\boldsymbol{\tau}}. \tag{3.104}$$

The components we can read off by inspection.

Associated Mathematica notebook for this problem (continuumProblemSet1Q3.cdf).

Exercise 3.4 Stress and equilibrium. (2012 p51, p4)

The stress tensor of a body is given by

$$\sigma = \begin{bmatrix} A \cos x & y^2 & Cx \\ y^2 & B \sin y & z \\ Cx & z & z^3 \end{bmatrix}. \tag{3.105}$$

Determine the constant A , B , and C if the body is in equilibrium.

Exercise 3.5 Compute stress tensors for some typical 3D forces.

PLACEHOLDER. Pick some 3D forces acting on unit volumes, and compute the stress tensors associated with them.

Exercise 3.6 Compute stress tensors for some typical 3D forces.

Referring to fig. 3.4, what form would the stress tensor take? PLACEHOLDER. I had assume that we have to use a radial form of the tensor?

Answer for Exercise 3.4

In the absence of external forces our equilibrium condition was

$$\partial_k \sigma_{ik} = 0. \tag{3.106}$$

In matrix form we wish to operate (to the left) with the gradient coordinate vector

$$\begin{aligned} 0 &= \sigma \overleftarrow{\nabla} \\ &= \begin{bmatrix} A \cos x & y^2 & Cx \\ y^2 & B \sin y & z \\ Cx & z & z^3 \end{bmatrix} \begin{bmatrix} \overleftarrow{\partial}_x \\ \overleftarrow{\partial}_y \\ \overleftarrow{\partial}_z \end{bmatrix} \\ &= \begin{bmatrix} \partial_x(A \cos x) + \partial_y(y^2) + \partial_z(Cx) \\ \cancel{\partial_x(y^2)} + \partial_y(B \sin y) + \partial_z(z) \\ \partial_x(Cx) + \cancel{\partial_y(z)} + \partial_z(z^3) \end{bmatrix} \\ &= \begin{bmatrix} -A \sin x + 2y \\ B \cos y + 1 \\ C + 3z^2 \end{bmatrix} \end{aligned} \tag{3.107}$$

So, our conditions for equilibrium will be satisfied when we have

$$\begin{aligned} A &= \frac{2y}{\sin x} \\ B &= -\frac{1}{\cos y} \\ C &= -3z^2, \end{aligned} \tag{3.108}$$

provided $y \neq 0$, and $y \neq \pi/2 + n\pi$ for integer n . If equilibrium is to hold along the $y = 0$ plane, then we must either also have $A = 0$ or also impose the restriction $x = m\pi$ (for integer m).

4

ELASTODYNAMICS.

4.1 ELASTIC WAVES.

Reading: Chapter I §7, chapter III (§22 - §26) of the text [13].

Example: sound or water waves (i.e. waves in a solid or liquid material that comes back to its original position.)

Definition 4.1: Elastic Wave

An elastic wave is a type of mechanical wave that propagates through or on the surface of a medium. The elasticity of the material provides the restoring force (that returns the material to its original state). The displacement and the restoring force are assumed to be linearly related.

In symbols we say

$$e_i(x_j, t) \text{ related to force,} \quad (4.1)$$

and specifically

$$\rho \frac{\partial^2 e_i}{\partial t^2} = F_i = \frac{\partial \sigma_{ij}}{\partial x_j}. \quad (4.2)$$

This is just Newton's second law, $F = ma$, but expressed in terms of a unit volume.

Should we have an external body force (per unit volume) f_i acting on the body then we must modify this, writing

$$\rho \frac{\partial^2 e_i}{\partial t^2} = \frac{\partial \sigma_{ij}}{\partial x_j} + f_i. \quad (4.3)$$

Note that we are separating out the "original" forces that produced the stress and strain on the object from any constant external forces that act on the body (i.e. a gravitational field).

With

$$e_{ij} = \frac{1}{2} \left(\frac{\partial e_i}{\partial x_j} + \frac{\partial e_j}{\partial x_i} \right), \quad (4.4)$$

we can expand the stress divergence, for the case of homogeneous deformation, in terms of the Lamé parameters

$$\sigma_{ij} = \lambda e_{kk} \delta_{ij} + 2\mu e_{ij}. \quad (4.5)$$

We compute

$$\begin{aligned} \frac{\partial \sigma_{ij}}{\partial x_j} &= \lambda \frac{\partial e_{kk}}{\partial x_j} \delta_{ij} + 2\mu \frac{\partial}{\partial x_j} \frac{1}{2} \left(\frac{\partial e_i}{\partial x_j} + \frac{\partial e_j}{\partial x_i} \right), \\ &= \lambda \frac{\partial e_{kk}}{\partial x_i} + \mu \left(\frac{\partial^2 e_i}{\partial x_j^2} + \frac{\partial^2 e_j}{\partial x_j \partial x_i} \right) \\ &= \lambda \frac{\partial}{\partial x_i} \frac{\partial e_k}{\partial x_k} + \mu \left(\frac{\partial^2 e_i}{\partial x_j^2} + \frac{\partial^2 e_k}{\partial x_k \partial x_i} \right) \\ &= (\lambda + \mu) \frac{\partial}{\partial x_i} \frac{\partial e_k}{\partial x_k} + \mu \frac{\partial^2 e_i}{\partial x_j^2}. \end{aligned} \quad (4.6)$$

We find, for homogeneous deformations, that the force per unit volume on our element of mass, in the absence of external forces (the body forces), takes the form

$$\rho \frac{\partial^2 e_i}{\partial t^2} = (\lambda + \mu) \frac{\partial^2 e_k}{\partial x_i \partial x_k} + \mu \frac{\partial^2 e_i}{\partial x_j^2}. \quad (4.7)$$

This can be seen to be equivalent to the vector relationship

$$\rho \frac{\partial^2 \mathbf{e}}{\partial t^2} = (\lambda + \mu) \nabla (\nabla \cdot \mathbf{e}) + \mu \nabla^2 \mathbf{e}. \quad (4.8)$$

4.2 P-WAVES.

Reading: §22 from [13].

Operating on this with the divergence operator, and writing $\theta = \nabla \cdot \mathbf{e}$, we have

$$\rho \frac{\partial^2 \nabla \cdot \mathbf{e}}{\partial t^2} = (\lambda + \mu) \nabla \cdot \nabla (\nabla \cdot \mathbf{e}) + \mu \nabla^2 (\nabla \cdot \mathbf{e}), \quad (4.9)$$

or

$$\frac{\partial^2 \theta}{\partial t^2} = \frac{\lambda + 2\mu}{\rho} \nabla^2 \theta. \quad (4.10)$$

We see that our divergence is governed by a wave equation where the speed of the wave C_L is specified by

$$C_L^2 = \frac{\lambda + 2\mu}{\rho}, \quad (4.11)$$

so the displacement wave equation is given by

$$\frac{\partial^2 \theta}{\partial t^2} = C_L^2 \nabla^2 \theta. \quad (4.12)$$

Let us look at the divergence of the displacement vector in some more detail. By definition this is just

$$\nabla \cdot \mathbf{e} = \frac{\partial e_1}{\partial x_1} + \frac{\partial e_2}{\partial x_2} + \frac{\partial e_3}{\partial x_3}. \quad (4.13)$$

Recall that the strain tensor e_{ij} was defined as

$$e_{ij} = \frac{1}{2} \left(\frac{\partial e_i}{\partial x_j} + \frac{\partial e_j}{\partial x_i} \right), \quad (4.14)$$

so we have

$$\begin{aligned} \frac{\partial e_1}{\partial x_1} &= e_{11} \\ \frac{\partial e_2}{\partial x_2} &= e_{22} \\ \frac{\partial e_3}{\partial x_3} &= e_{33}. \end{aligned} \quad (4.15)$$

So the divergence in question can be written in terms of the strain tensor

$$\nabla \cdot \mathbf{e} = e_{11} + e_{22} + e_{33} = e_{ii}. \quad (4.16)$$

We also found that the trace of the strain tensor was the relative change in volume. We call this the dilatation. A measure of change in volume as illustrated (badly) in fig. 4.1 This idea can be found nicely animated in the wikipedia page [30].

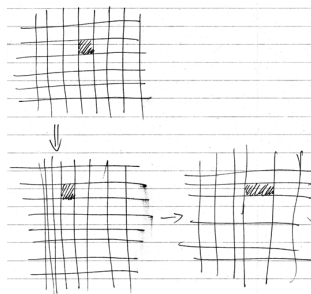

Figure 4.1: Illustrating changes in a control volume.

4.3 S-WAVES.

Now let us operate on our eq. (4.8) with the curl operator

$$\rho \frac{\partial^2 \nabla \times \mathbf{e}}{\partial t^2} = (\lambda + \mu) \nabla \times (\nabla (\nabla \cdot \mathbf{e})) + \mu \nabla^2 (\nabla \times \mathbf{e}). \quad (4.17)$$

Writing

$$\boldsymbol{\omega} = \nabla \times \mathbf{e}, \quad (4.18)$$

and observing that $\nabla \times \nabla f = 0$ (with $f = \nabla \cdot \mathbf{e}$), we find

$$\rho \frac{\partial^2 \boldsymbol{\omega}}{\partial t^2} = \mu \nabla^2 \boldsymbol{\omega}. \quad (4.19)$$

We call this the S-wave equation, and write C_T for the speed of this wave

$$C_T^2 = \frac{\mu}{\rho}, \quad (4.20)$$

so that we have

$$\frac{\partial^2 \boldsymbol{\omega}}{\partial t^2} = C_T^2 \nabla^2 \boldsymbol{\omega}. \quad (4.21)$$

Again, we can find nice animations of this on wikipedia [21].

4.4 RELATIVE SPEEDS OF THE P-WAVES AND S-WAVES.

Taking ratios of the wave speeds we find

$$\frac{C_L}{C_T} = \sqrt{\frac{\lambda + 2\mu}{\mu}} = \sqrt{\frac{\lambda}{\mu} + 2}. \quad (4.22)$$

Since both $\lambda > 0$ and $\mu > 0$, we have

$$C_L > C_T. \quad (4.23)$$

Divergence (p-waves) are faster than rotational (s-waves) waves.

In terms of the Poisson ratio $\nu = \lambda/(2(\lambda + \mu))$, we find

$$\frac{\mu}{\lambda} = \frac{1}{2\nu} - 1. \quad (4.24)$$

we see that Poisson's ratio characterizes the speeds of the waves for the medium

$$\frac{C_L}{C_T} = \sqrt{\frac{2(1-\nu)}{1-2\nu}}. \quad (4.25)$$

4.5 ASSUMING A GRADIENT PLUS CURL REPRESENTATION.

Let us assume that our displacement can be written in terms of a gradient and curl as we do for the electric field

$$\mathbf{e} = \nabla\phi + \nabla \times \mathbf{H}. \quad (4.26)$$

Inserting this into eq. (4.8) we find

$$\begin{aligned} \rho \frac{\partial^2(\nabla\phi + \nabla \times \mathbf{H})}{\partial t^2} \\ = (\lambda + \mu)\nabla(\nabla \cdot (\nabla\phi + \nabla \times \mathbf{H})) + \mu\nabla^2(\nabla\phi + \nabla \times \mathbf{H}). \end{aligned} \quad (4.27)$$

The first term on the RHS can be simplified. First note that the divergence of the gradient is just a Laplacian

$$\nabla \cdot \nabla\phi = \nabla^2\phi, \quad (4.28)$$

and then note that the divergence of a curl is zero

$$\nabla \cdot (\nabla \times \mathbf{H}) = \partial_k(\partial_a H_b \epsilon_{abk}) = 0. \quad (4.29)$$

The zero follows from the fact that the antisymmetric sum of symmetric partials is zero (assuming sufficient continuity). Grouping terms we have

$$\nabla \left(\rho \frac{\partial^2\phi}{\partial t^2} - (\lambda + 2\mu)\nabla^2\phi \right) + \nabla \times \left(\rho \frac{\partial^2\mathbf{H}}{\partial t^2} - \mu\nabla^2\mathbf{H} \right) = 0. \quad (4.30)$$

When the material is infinite in scope, so that boundary value coupling is not a factor, we can write this as a set of independent P-wave and S-wave equations

$$\rho \frac{\partial^2 \phi}{\partial t^2} - (\lambda + 2\mu) \nabla^2 \phi = 0. \quad (4.31)$$

The P-wave is irrotational (curl free).

$$\rho \frac{\partial^2 \mathbf{H}}{\partial t^2} - \mu \nabla^2 \mathbf{H} = 0. \quad (4.32)$$

The S-wave is solenoidal (divergence free).

4.6 A COUPLE SUMMARIZING STATEMENTS.

- P-waves: irrotational. Volume not preserved.
- S-waves: divergence free. Shearing forces are present and volume is preserved.
- P-waves are faster than S-waves.

4.7 PHASOR DESCRIPTION OF ELASTIC WAVES.

Let us introduce a phasor representation (again following §22 of the text [13])

$$\begin{aligned} \phi &= A \exp(i(\mathbf{k} \cdot \mathbf{x} - \omega t)) \\ \mathbf{H} &= \mathbf{B} \exp(i(\mathbf{k} \cdot \mathbf{x} - \omega t)). \end{aligned} \quad (4.33)$$

Operating with the gradient we find

$$\begin{aligned} \mathbf{P} &= \nabla \phi \\ &= \mathbf{e}_k \partial_k A \exp(i(\mathbf{k} \cdot \mathbf{x} - \omega t)) \\ &= \mathbf{e}_k \partial_k A \exp(i(k_m x_m - \omega t)) \\ &= \mathbf{e}_k i k_k A \exp(i(k_m x_m - \omega t)) \\ &= i \mathbf{k} A \exp(i(\mathbf{k} \cdot \mathbf{x} - \omega t)) \\ &= i \mathbf{k} \phi. \end{aligned} \quad (4.34)$$

We can also write

$$\mathbf{P} = \mathbf{k} \phi', \quad (4.35)$$

where ϕ' is the derivative of ϕ “with respect to its argument”. Here argument must mean the entire phase $\mathbf{k} \cdot \mathbf{x} - \omega t$.

$$\phi' = \frac{d\phi(\mathbf{k} \cdot \mathbf{x} - \omega t)}{d(\mathbf{k} \cdot \mathbf{x} - \omega t)} = i\phi. \quad (4.36)$$

Actually, argument is a good label here, since we can use the word in the complex number sense.

For the curl term we find

$$\begin{aligned} \mathbf{S} &= \nabla \times \mathbf{H} \\ &= \mathbf{e}_a \partial_b H_c \epsilon_{abc} \\ &= \mathbf{e}_a \partial_b \epsilon_{abc} B_c \exp(i(\mathbf{k} \cdot \mathbf{x} - \omega t)) \\ &= \mathbf{e}_a \partial_b \epsilon_{abc} B_c \exp(i(k_m x_m - \omega t)) \\ &= \mathbf{e}_a i k_b \epsilon_{abc} B_c \exp(i(\mathbf{k} \cdot \mathbf{x} - \omega t)) \\ &= i\mathbf{k} \times \mathbf{H}. \end{aligned} \quad (4.37)$$

Again writing

$$\mathbf{H}' = \frac{d\mathbf{H}(\mathbf{k} \cdot \mathbf{x} - \omega t)}{d(\mathbf{k} \cdot \mathbf{x} - \omega t)} = i\mathbf{H} \quad (4.38)$$

we can write the S wave as

$$\mathbf{S} = \mathbf{k} \times \mathbf{H}'. \quad (4.39)$$

4.8 SOME WAVE TYPES DESCRIBED.

The following wave types were noted, but not defined:

- Rayleigh wave. This is discussed in §24 of the text (a wave that propagates near the surface of a body without penetrating into it). Wikipedia has an illustration of one possible mode of propagation [31].
- Love wave. These are not discussed in the text, but wikipedia [29] describes them as polarized shear waves (where the figure indicates that the shear displacements are perpendicular to the direction of propagation).

Some illustrations from the class notes were also shown.

4.9 SUMMARY.

4.9.1 *Elastic displacement equation.*

It was argued that the equation relating the time evolution of a one of the vector displacement coordinates was given by

$$\rho \frac{\partial^2 u_i}{\partial t^2} = \frac{\partial \sigma_{ij}}{\partial x_j} + f_i, \quad (4.40)$$

where the divergence term $\partial \sigma_{ij} / \partial x_j$ is the internal force per unit volume on the object and f_i is the external force. Employing the constitutive relation we showed that this can be expanded as

$$\rho \frac{\partial^2 u_i}{\partial t^2} = (\lambda + \mu) \frac{\partial^2 u_k}{\partial x_i \partial x_k} + \mu \frac{\partial^2 u_i}{\partial x_j^2}, \quad (4.41)$$

or in vector form

$$\rho \frac{\partial^2 \mathbf{u}}{\partial t^2} = (\lambda + \mu) \nabla (\nabla \cdot \mathbf{u}) + \mu \nabla^2 \mathbf{u}. \quad (4.42)$$

4.9.2 *Equilibrium.*

When a body is in static equilibrium eq. (4.40) reduces to just a simple force balance

$$f_i = - \frac{\partial \sigma_{ij}}{\partial x_j}. \quad (4.43)$$

In particular, if there are no external forces then all of these divergences must be zero.

4.9.3 *P-waves.*

Operating on eq. (4.42) with the divergence operator, and writing $\Theta = \nabla \cdot \mathbf{u}$, a quantity that was our relative change in volume in the diagonal strain basis, we were able to find this divergence obeys a wave equation

$$\frac{\partial^2 \Theta}{\partial t^2} = \frac{\lambda + 2\mu}{\rho} \nabla^2 \Theta. \quad (4.44)$$

We called these P-waves.

4.9.4 *S-waves.*

Similarly, operating on eq. (4.42) with the curl operator, and writing $\boldsymbol{\omega} = \nabla \times \mathbf{u}$, we were able to find this curl also obeys a wave equation

$$\rho \frac{\partial^2 \boldsymbol{\omega}}{\partial t^2} = \mu \nabla^2 \boldsymbol{\omega}. \quad (4.45)$$

These we called S-waves. We also noted that the (transverse) compression waves (P-waves) with speed $C_T = \sqrt{\mu/\rho}$, traveled faster than the (longitudinal) vorticity (S) waves with speed $C_L = \sqrt{(\lambda + 2\mu)/\rho}$ since $\lambda > 0$ and $\mu > 0$, and

$$\frac{C_L}{C_T} = \sqrt{\frac{\lambda + 2\mu}{\mu}} = \sqrt{\frac{\lambda}{\mu} + 2}. \quad (4.46)$$

4.9.5 *Scalar and vector potential representation.*

Assuming a vector displacement representation with gradient and curl components

$$\mathbf{u} = \nabla \phi + \nabla \times \mathbf{H}, \quad (4.47)$$

We found that the displacement time evolution equation split nicely into curl free and divergence free terms

$$\nabla \left(\rho \frac{\partial^2 \phi}{\partial t^2} - (\lambda + 2\mu) \nabla^2 \phi \right) + \nabla \times \left(\rho \frac{\partial^2 \mathbf{H}}{\partial t^2} - \mu \nabla^2 \mathbf{H} \right) = 0. \quad (4.48)$$

When neglecting boundary value effects this could be written as a pair of independent equations

$$\rho \frac{\partial^2 \phi}{\partial t^2} - (\lambda + 2\mu) \nabla^2 \phi = 0 \quad (4.49a)$$

$$\rho \frac{\partial^2 \mathbf{H}}{\partial t^2} - \mu \nabla^2 \mathbf{H} = 0. \quad (4.49b)$$

This are the irrotational (curl free) P-wave and solenoidal (divergence free) S-wave equations respectively.

4.9.6 *Phasor description.*

It was mentioned that we could assume a phasor representation for our potentials, writing

$$\phi = A \exp(i(\mathbf{k} \cdot \mathbf{x} - \omega t)), \quad (4.50a)$$

$$\mathbf{H} = \mathbf{B} \exp(i(\mathbf{k} \cdot \mathbf{x} - \omega t)), \quad (4.50b)$$

finding

$$\mathbf{u} = i\mathbf{k}\phi + i\mathbf{k} \times \mathbf{H}. \quad (4.51)$$

We did nothing with neither the potential nor the phasor theory for solid displacement time evolution, and presumably will not on the exam either.

4.9.7 *Some wave types.*

Some time was spent on qualitative descriptions and review of descriptions for solutions of the time evolution elasticity equations.

- P-waves [30]. Irrotational, non volume preserving body wave.
- S-waves [21]. Divergence free body wave. Shearing forces are present and volume is preserved (slower than S-waves)
- Rayleigh wave [31]. A surface wave that propagates near the surface of a body without penetrating into it. It is pointed out in the class notes in the seismogram figure that these, while moving slower than the P (primary) or S (secondary) waves, have larger amplitude and are therefore the most destructive.
- Love wave [29]. A polarized shear surface wave with the shear displacements moving perpendicular to the direction of propagation.

4.10 PROBLEMS.

Exercise 4.1 **P-waves, S-waves, Love-waves.** (2012 midterm, p1 a)

Show that in **P**-waves the divergence of the displacement vector represents a measure of the relative change in the volume of the body.

Answer for Exercise 4.1

The **P**-wave equation was a result of operating on the displacement equation with the divergence operator

$$\nabla \cdot \left(\rho \frac{\partial^2 \mathbf{e}}{\partial t^2} = (\lambda + \mu) \nabla (\nabla \cdot \mathbf{e}) + \mu \nabla^2 \mathbf{e} \right), \quad (4.52)$$

we obtain

$$\frac{\partial^2}{\partial t^2} (\nabla \cdot \mathbf{e}) = \frac{\lambda + 2\mu}{\rho} \nabla^2 (\nabla \cdot \mathbf{e}). \quad (4.53)$$

We have a wave equation where the “waving” quantity is $\Theta = \nabla \cdot \mathbf{e}$. Explicitly

$$\begin{aligned} \Theta &= \nabla \cdot \mathbf{e} \\ &= \frac{\partial e_1}{\partial x} + \frac{\partial e_2}{\partial y} + \frac{\partial e_3}{\partial z}. \end{aligned} \quad (4.54)$$

Recall that, in a coordinate basis for which the strain e_{ij} is diagonal we have

$$\begin{aligned} dx' &= \sqrt{1 + 2e_{11}} dx \\ dy' &= \sqrt{1 + 2e_{22}} dy \\ dz' &= \sqrt{1 + 2e_{33}} dz. \end{aligned} \quad (4.55)$$

Expanding in Taylor series to $O(1)$ we have for $i = 1, 2, 3$ (no sum)

$$dx'_i \approx (1 + e_{ii}) dx_i, \quad (4.56)$$

so the displaced volume is

$$\begin{aligned} dV' &= dx_1 dx_2 dx_3 (1 + e_{11})(1 + e_{22})(1 + e_{33}) \\ &= dx_1 dx_2 dx_3 (1 + e_{11} + e_{22} + e_{33} + O(e_{kk}^2)). \end{aligned} \quad (4.57)$$

Since

$$\begin{aligned}
 e_{11} &= \frac{1}{2} \left(\frac{\partial e_1}{\partial x} + \frac{\partial e_1}{\partial x} \right) = \frac{\partial e_1}{\partial x} \\
 e_{22} &= \frac{1}{2} \left(\frac{\partial e_2}{\partial y} + \frac{\partial e_2}{\partial y} \right) = \frac{\partial e_2}{\partial y} \\
 e_{33} &= \frac{1}{2} \left(\frac{\partial e_3}{\partial z} + \frac{\partial e_3}{\partial z} \right) = \frac{\partial e_3}{\partial z},
 \end{aligned}
 \tag{4.58}$$

we have

$$dV' = (1 + \nabla \cdot \mathbf{e})dV, \tag{4.59}$$

or

$$\frac{dV' - dV}{dV} = \nabla \cdot \mathbf{e}. \tag{4.60}$$

The relative change in volume can therefore be expressed as the divergence of \mathbf{e} , the displacement vector, and it is this relative volume change that is “waving” in the **P**-wave equation as illustrated in the following fig. 4.2 sample 1D compression wave

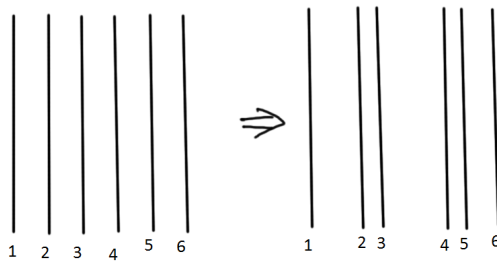

Figure 4.2: A 1D compression wave.

Exercise 4.2 P-waves and S-waves. (2012 midterm, p1 b)

Between a **P**-wave and an **S**-wave which one is longitudinal and which one is transverse?

Answer for Exercise 4.2

P-waves are longitudinal. **S**-waves are transverse.

Exercise 4.3 Speed of P-waves and S-waves. (2012 midterm, p1 c)

Whose speed is higher?

Answer for Exercise 4.3

From the (midterm) formula sheet we have

$$\begin{aligned} \left(\frac{c_L}{c_T}\right)^2 &= \frac{\lambda + 2\mu}{\rho} \frac{\rho}{\mu} \\ &= \frac{\lambda}{\mu} + 2 \\ &> 1, \end{aligned} \tag{4.61}$$

so **P**-waves travel faster than **S**-waves.

Exercise 4.4 Love waves. (2012 midterm, p1 d)

Is Love wave a body wave or a surface wave?

Answer for Exercise 4.4

Love waves are surface waves, traveling in a medium that can slide on top of another surface. They are characterized by shear displacements perpendicular to the direction of propagation.

Reviewing for the final I see that I had answered this wrong, and have corrected it. I had described a Rayleigh wave (also a surface wave). A Rayleigh wave is characterized by vorticity rotating backwards compared to the direction of propagation as shown in fig. 4.3

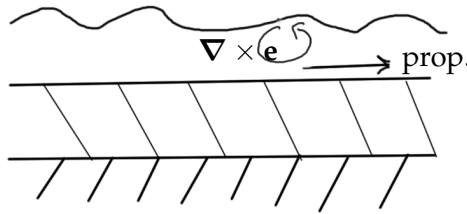

Figure 4.3: Rayleigh wave illustrated.

Exercise 4.5 Equilibrium.

Suppose that the state of a body is given by

$$\begin{aligned} \sigma_{11} &= Ax^4y^3\sigma_{22} \\ &= 3Bx^2y^5\sigma_{12} \\ &= -Cx^3y^4. \end{aligned} \tag{4.62}$$

Determine the constants A , B and C so that the body is in equilibrium (2011 Final Exam question II).

Answer for Exercise 4.5

We have

$$\begin{aligned} 0 &= \frac{\partial \sigma_{1j}}{\partial x_j} \\ &= \frac{\partial \sigma_{11}}{\partial x} + \frac{\partial \sigma_{12}}{\partial y} \\ &= 4Ax^3y^3 - 4Cx^3y^3, \end{aligned} \tag{4.63}$$

and

$$\begin{aligned} 0 &= \frac{\partial \sigma_{2j}}{\partial x_j} \\ &= \frac{\partial \sigma_{21}}{\partial x} + \frac{\partial \sigma_{22}}{\partial y} \\ &= -3Cx^2y^4 + 15Bx^2y^4. \end{aligned} \tag{4.64}$$

We must then have

$$\begin{aligned} 0 &= A - C0 \\ &= -C + 5B, \end{aligned} \tag{4.65}$$

or

$$A = CB = \frac{C}{5}. \tag{4.66}$$

Exercise 4.6 **Tsunami.** (2011 final)

Explain how the strain energy of tectonic plates causes Tsunami.

Answer for Exercise 4.6

The root cause of the Tsunami is the earthquake under the body of water. Once that earthquake occurs we will have a body wave in the mantle, which will trigger a much more destructive (higher amplitude) surface wave (probably of the Rayleigh type). Looking back to the connection with strain energy, we see that once we have a change in the strain divergence, we will have to have a restoring force to put things back in equilibrium. That restoring force can come either from the surrounding mantle or the fluid above it, and it is that fluid restoring force that induces the wave as a side effect.

Exercise 4.7 Wave equation solutions.

PLACEHOLDER.

NAVIER-STOKES EQUATION.

5.1 TIME DEPENDENT DISPLACEMENTS.

Reading: §1.4 from [2].

In fluid dynamics we look at displacements with respect to time as illustrated in fig. 5.1

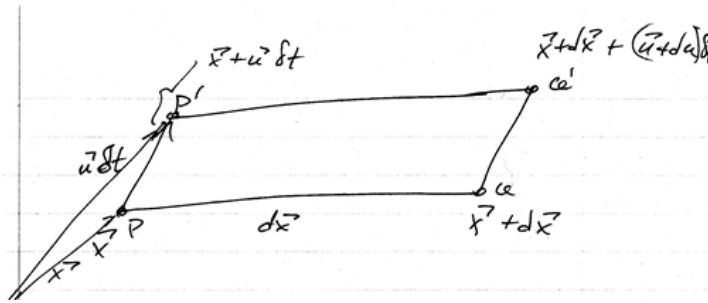

Figure 5.1: Differential displacement.

$$dx' = dx + du \delta t. \quad (5.1)$$

In index notation

$$\begin{aligned} dx'_i &= dx_i + du_i \delta t \\ &= dx_i + \frac{\partial u_i}{\partial x_j} dx_j \delta t. \end{aligned} \quad (5.2)$$

We define the strain tensor, still symmetric, using only first order partials

$$e_{ij} = \frac{1}{2} \left(\frac{\partial u_i}{\partial x_j} + \frac{\partial u_j}{\partial x_i} \right). \quad (5.3)$$

We also define an antisymmetric vorticity tensor

$$\omega_{ij} = \frac{1}{2} \left(\frac{\partial u_i}{\partial x_j} - \frac{\partial u_j}{\partial x_i} \right). \quad (5.4)$$

Effect of e_{ij} when diagonalized

$$e_{ij} = \begin{bmatrix} e_{11} & 0 & 0 \\ 0 & e_{22} & 0 \\ 0 & 0 & e_{33} \end{bmatrix}, \quad (5.5)$$

so that in this frame of reference we have

$$\begin{aligned} dx'_1 &= (1 + e_{11}\delta t)dx_1 \\ dx'_2 &= (1 + e_{22}\delta t)dx_2 \\ dx'_3 &= (1 + e_{33}\delta t)dx_3. \end{aligned} \quad (5.6)$$

Let us find the matrix form of the antisymmetric tensor. We find

$$\omega_{11} = \omega_{22} = \omega_{33} = 0. \quad (5.7)$$

Introducing a vorticity vector

$$\boldsymbol{\omega} = \nabla \times \mathbf{u}, \quad (5.8)$$

we find

$$\begin{aligned} \omega_{12} &= \frac{1}{2} \left(\frac{\partial u_1}{\partial x_2} - \frac{\partial u_2}{\partial x_1} \right) = -\frac{1}{2}(\nabla \times \mathbf{u})_3 \\ \omega_{23} &= \frac{1}{2} \left(\frac{\partial u_2}{\partial x_3} - \frac{\partial u_3}{\partial x_2} \right) = -\frac{1}{2}(\nabla \times \mathbf{u})_1 \\ \omega_{31} &= \frac{1}{2} \left(\frac{\partial u_3}{\partial x_1} - \frac{\partial u_1}{\partial x_3} \right) = -\frac{1}{2}(\nabla \times \mathbf{u})_2. \end{aligned} \quad (5.9)$$

Writing

$$\Omega_i = \frac{1}{2}\omega_i, \quad (5.10)$$

we find the matrix form of this antisymmetric tensor

$$\omega_{ij} = \begin{bmatrix} 0 & -\Omega_3 & \Omega_2 \\ \Omega_3 & 0 & -\Omega_1 \\ -\Omega_2 & \Omega_1 & 0 \end{bmatrix}, \quad (5.11)$$

and

$$\begin{aligned} dx'_1 &= dx_1 + (\omega_{11}dx_1 + \omega_{12}dx_2 + \omega_{13}dx_3) \delta t \\ &= dx_1 + (\omega_{12}dx_2 + \omega_{13}dx_3) \delta t \\ &= dx_1 + (\Omega_2dx_3 - \Omega_3dx_2) \delta t. \end{aligned} \quad (5.12)$$

Doing this for all components we find

$$d\mathbf{x}' = d\mathbf{x} + (\boldsymbol{\Omega} \times d\mathbf{x})\delta t. \quad (5.13)$$

The tensor ω_{ij} implies rotation of a control volume with an angular velocity $\boldsymbol{\Omega} = \boldsymbol{\omega}/2$ (half the vorticity vector). In general we have

$$dx'_i = dx_i + e_{ij}dx_j\delta t + \omega_{ij}dx_j\delta t. \quad (5.14)$$

5.2 COMPARING TO ELASTOSTATICS.

Recall that for elastic materials we derived the strain tensor by considering differences in squared displacements? It was not obvious to me why we had no such term when analyzing solids.

For solids we could have also done this first order decomposition of the displacement (per unit time) of a point. Note that this is really just a gradient evaluation, split into coordinates by grouping into symmetric and antisymmetric terms. Here, as in the solids case, we write

$$\mathbf{u} = \mathbf{x}' - \mathbf{x}, \quad (5.15)$$

$$\begin{aligned} x'_i &= x_i + (\nabla u_i) \cdot d\mathbf{x}\delta t \\ &= x_i + \frac{\partial u_i}{\partial x_j} dx_j \delta t \\ &= x_i + \frac{1}{2} \left(\frac{\partial u_i}{\partial x_j} + \frac{\partial u_j}{\partial x_i} \right) dx_j \delta t + \frac{1}{2} \left(\frac{\partial u_i}{\partial x_j} - \frac{\partial u_j}{\partial x_i} \right) dx_j \delta t \\ &= x_i + e_{ij} dx_j \delta t + \omega_{ij} dx_j \delta t. \end{aligned} \quad (5.16)$$

5.3 ANTISYMMETRIC TERM, THE VORTICITY.

With

$$\boldsymbol{\omega} = \nabla \times \mathbf{u}, \quad (5.17)$$

we introduce the dual vector

$$\boldsymbol{\Omega} = \Omega_k \mathbf{e}_k = \frac{1}{2} \boldsymbol{\omega}, \quad (5.18)$$

defined according to

$$\begin{aligned}\Omega_1 &= \frac{1}{2}\omega_{32} = \frac{1}{2}\omega_1 \\ \Omega_2 &= \frac{1}{2}\omega_{13} = \frac{1}{2}\omega_2 \\ \Omega_3 &= \frac{1}{2}\omega_{21} = \frac{1}{2}\omega_3.\end{aligned}\tag{5.19}$$

With

$$\omega_k = \epsilon_{ijk}\partial_i u_j,\tag{5.20}$$

we can write

$$\Omega_k = \frac{1}{2}\epsilon_{ijk}\partial_i u_j.\tag{5.21}$$

In matrix form this becomes

$$\omega_{ij} = \begin{bmatrix} 0 & -\Omega_3 & \Omega_2 \\ \Omega_3 & 0 & -\Omega_1 \\ -\Omega_2 & \Omega_1 & 0 \end{bmatrix}.\tag{5.22}$$

For the special case $e_{ij} = 0$, our displacement equation in vector form becomes

$$d\mathbf{x}' = d\mathbf{x} + \boldsymbol{\Omega} \times d\mathbf{x}\delta t.\tag{5.23}$$

Let us do a quick verification that this is all kosher.

$$\begin{aligned}(\boldsymbol{\Omega} \times d\mathbf{x})_i &= \Omega_r dx_s \epsilon_{rsi} \\ &= \left(\frac{1}{2}\epsilon_{abr}\partial_a u_b\right) dx_s \epsilon_{rsi} \\ &= \frac{1}{2}\partial_a u_b dx_s \delta_{si}^{[ab]} \\ &= \frac{1}{2}(\partial_s u_i - \partial_i u_s) dx_s \\ &= \frac{1}{2}\left(-\frac{\partial u_s}{\partial x_i} + \frac{\partial u_i}{\partial x_s}\right) dx_s \\ &= \frac{1}{2}\left(\frac{\partial u_i}{\partial x_j} - \frac{\partial u_j}{\partial x_i}\right) dx_j \\ &= \omega_{ij} dx_j.\end{aligned}\tag{5.24}$$

All's good in the world of signs and indices.

5.4 SYMMETRIC TERM, THE STRAIN TENSOR.

Now let us look at the symmetric term. With the initial volume

$$dV = dx_1 dx_2 dx_3, \quad (5.25)$$

and the final volume written assuming that we are working in our principle strain basis, we have (very much like the solids case)

$$\begin{aligned} dV' &= dx'_1 dx'_2 dx'_3 \\ &= (1 + e_{11} \delta t) dx_1 + (1 + e_{22} \delta t) dx_2 + (1 + e_{33} \delta t) dx_3 \\ &= (1 + (e_{11} + e_{22} + e_{33}) \delta t) dx_1 dx_2 dx_3 + O((\delta t)^2) \\ &= \left(1 + \left(\frac{\partial u_1}{\partial x_1} + \frac{\partial u_2}{\partial x_2} + \frac{\partial u_3}{\partial x_3} \right) \delta t \right) dV \\ &= (1 + (\nabla \cdot \mathbf{u}) \delta t) dV. \end{aligned} \quad (5.26)$$

So much like we expressed the relative change of volume in solids, we now can express the relative change of volume per unit time as

$$\frac{dV' - dV}{dV \delta t} = \nabla \cdot \mathbf{u}, \quad (5.27)$$

or

$$\frac{\delta(dV)}{dV \delta t} = \nabla \cdot \mathbf{u}. \quad (5.28)$$

We identify the divergence of the displacement as the relative change in volume per unit time.

5.5 NEWTONIAN FLUIDS.

Definition 5.1: Newtonian Fluids

A fluid for which the rate of strain tensor is linearly related to stress tensor.

For such a fluid, the constitutive relation takes the form

$$\sigma_{ij} = -p \delta_{ij} + 2\mu e_{ij}, \quad (5.29)$$

where p is called the isotropic pressure, and μ is the viscosity of the fluid. For comparison, in solids we had

$$\sigma_{ij} = \lambda e_{kk} \delta_{ij} + 2\mu e_{ij}. \quad (5.30)$$

While we are allowing for rotation in the fluids (ω_{ij}) that we did not consider for solids, we now impose a requirement that the strain tensor trace is not a function of the fluid displacements, with

$$\lambda e_{kk} = \lambda \nabla \cdot \mathbf{u} = -p. \quad (5.31)$$

What is the physical justification for this? In words this was explained after class as the effect of rotation invariance with an attempt to measure the pressure at a given point in the fluid. It does not matter what direction we place our pressure measurement device at a given fixed location in the fluid. Note that this does not mean the pressure itself is constant. For example with a gravitational body force applied, our pressure will increase with depth in the fluid. Noting this provides a nice physical interpretation of the trace of the strain tensor.

Can we mathematically justify this explanation? We see above that we have

$$\nabla \cdot \mathbf{u} = \frac{\delta \ln(dV)}{\delta t}, \quad (5.32)$$

so we are in effect making the identification

$$\ln dV = -pt/\lambda + \ln dV_0, \quad (5.33)$$

or

$$dV = dV_0 e^{-pt/\lambda}. \quad (5.34)$$

The relative change in a differential volume element changes exponentially.

5.6 DIMENSIONS OF VISCOSITY.

$$[\mu] = \frac{\text{M}}{\text{LT}}. \quad (5.35)$$

Some examples

- $\mu_{\text{air}} = 1.8 \times 10^{-5} \frac{\text{kg}}{\text{m s}},$
- $\mu_{\text{water}} = 1.1 \times 10^{-3} \frac{\text{kg}}{\text{m s}},$
- $\mu_{\text{glycerin}} = 2.3 \frac{\text{kg}}{\text{m s}}.$

5.7 CONSERVATION OF MASS IN FLUID.

Referring to fig. 5.2 we have a flow rate

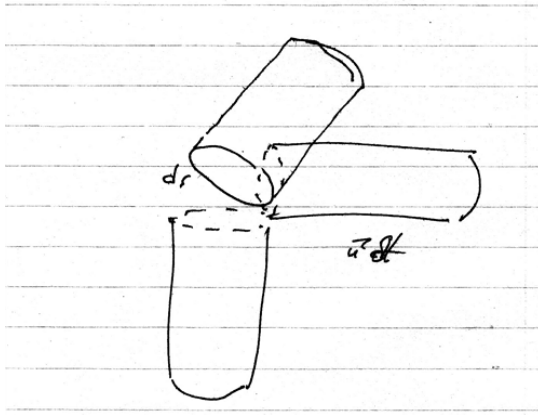

Figure 5.2: Area projections for mass conservation argument.

$$\rho \mathbf{u} \delta t ds, \quad (5.36)$$

or

$$\rho \mathbf{u} ds, \quad (5.37)$$

per unit time. Here the velocity of fluid particle is \mathbf{u} .

$$\oint \rho \mathbf{u} \cdot d\mathbf{s}, \quad (5.38)$$

we must have

$$\frac{\partial}{\partial t} \int \rho dV = - \oint \rho \mathbf{u} \cdot d\mathbf{s}. \quad (5.39)$$

With

$$dm = \rho dV, \quad (5.40)$$

the mass flow rate is

$$\frac{dm}{dt} = \frac{d}{dt}(\rho dV), \text{ which is} \quad (5.41)$$

- positive if fluid is coming in, and
- negative if fluid is going out.

By Green's theorem

$$\oint \mathbf{A} \cdot d\mathbf{s} = \int_V (\nabla \cdot \mathbf{A}) dV, \quad (5.42)$$

so we have

$$-\oint \rho \mathbf{u} \cdot d\mathbf{s} = -\int \nabla \cdot (\rho \mathbf{u}) dV, \quad (5.43)$$

and must have

$$\int \left(\frac{\partial \rho}{\partial t} + \nabla \cdot (\rho \mathbf{u}) \right) dV = 0. \quad (5.44)$$

The total mass has to be conserved. The mass that is leaving the volume per unit time must move through the surface of the volume in that time. In differential form this is ¹

$$\boxed{\frac{\partial \rho}{\partial t} + \nabla \cdot (\rho \mathbf{u}) = 0.} \quad (5.45)$$

Operating by chain rule we can write this as

$$\frac{\partial \rho}{\partial t} + \mathbf{u} \cdot \nabla \rho = -\rho \nabla \cdot \mathbf{u}. \quad (5.46)$$

To make sense of this, observe that we have for $f = f(x, y, z, t)$

$$\begin{aligned} \delta f &= \lim_{\delta t \rightarrow 0} \frac{\delta f}{\delta t} dt \\ &= \frac{\partial f}{\partial x} \frac{\delta x}{\delta t} + \frac{\partial f}{\partial y} \frac{\delta y}{\delta t} + \frac{\partial f}{\partial z} \frac{\delta z}{\delta t} + \frac{\partial f}{\partial t} \\ &= (\nabla f) \cdot \mathbf{u} + \frac{\partial f}{\partial t}, \end{aligned} \quad (5.47)$$

so we have

$$\frac{\partial \rho}{\partial t} + \mathbf{u} \cdot \nabla \rho = \frac{d\rho}{dt}, \quad (5.48)$$

or

$$\frac{d\rho}{dt} = -\rho \nabla \cdot \mathbf{u}. \quad (5.49)$$

¹ Note that this is what I had thought we called the continuity equation in physics, but I think we were using that for $\nabla \cdot \mathbf{u} = 0$ instead.

5.8 INCOMPRESSIBLE FLUID.

When the density does not change note that we have

$$\frac{d\rho}{dt} = 0, \quad (5.50)$$

which then implies

$$\boxed{\nabla \cdot \mathbf{u} = 0}, \quad (5.51)$$

at all points in the fluid.

5.9 CONSERVATION OF MOMENTUM (NAVIER-STOKES EQUATION).

Reading: §6.* from [2].

In classical mechanics we have

$$\mathbf{f} = m\mathbf{a}, \quad (5.52)$$

our analogue here is found in terms of the stress tensor

$$\int_V F_i dV = \int_V \frac{\partial \sigma_{ij}}{\partial x_j} dV. \quad (5.53)$$

Here F_i is the force per unit volume. With body forces we have

$$F_i = \rho \frac{du_i}{dt} = \frac{\partial \sigma_{ij}}{\partial x_j} + \rho f_i, \quad (5.54)$$

where f_i is an external force per unit volume. Observe that σ_{ij} , through the constitutive relation, includes both contributions of linear displacement and the vorticity component. From the constitutive relation eq. (5.29), we have

$$\begin{aligned} \frac{\partial \sigma_{ij}}{\partial x_j} &= -\frac{\partial p}{\partial x_j} \delta_{ij} + 2\mu \frac{\partial e_{ij}}{\partial x_j} \\ &= -\frac{\partial p}{\partial x_i} + 2\mu \frac{\partial}{\partial x_j} \left(\frac{1}{2} \left(\frac{\partial u_i}{\partial x_j} + \frac{\partial u_j}{\partial x_i} \right) \right) \\ &= -\frac{\partial p}{\partial x_i} + \mu \left(\frac{\partial^2 u_i}{\partial x_j \partial x_j} + \frac{\partial^2 u_j}{\partial x_i \partial x_j} \right). \end{aligned} \quad (5.55)$$

Observe that the term

$$\frac{\partial^2 u_i}{\partial x_j \partial x_j}, \quad (5.56)$$

is the i^{th} component of $\nabla^2 \mathbf{u}$, whereas

$$\begin{aligned} \frac{\partial^2 u_j}{\partial x_i \partial x_j} &= \frac{\partial}{\partial x_i} \left(\frac{\partial u_j}{\partial x_j} \right) \\ &= \frac{\partial}{\partial x_i} (\nabla \cdot \mathbf{u}), \end{aligned} \quad (5.57)$$

is the i^{th} component of $\nabla(\nabla \cdot \mathbf{u})$. Therefore

$$\rho \frac{du_i}{dt} = \left(-\nabla p + \mu \nabla^2 \mathbf{u} + \mu \nabla(\nabla \cdot \mathbf{u}) + \rho \mathbf{f} \right)_i, \quad (5.58)$$

or in vector notation

$$\rho \frac{d\mathbf{u}}{dt} = -\nabla p + \mu \nabla^2 \mathbf{u} + \mu \nabla(\nabla \cdot \mathbf{u}) + \rho \mathbf{f}. \quad (5.59)$$

We can expand this a bit more writing our velocity $\mathbf{u} = \mathbf{u}(x, y, z, t)$ differential

$$du_i = \frac{\partial u_i}{\partial x_j} \delta x_j + \frac{\partial u_i}{\partial t} \delta t. \quad (5.60)$$

Considering rates

$$\frac{du_i}{dt} = \frac{\partial u_i}{\partial x_j} \frac{dx_j}{dt} + \frac{\partial u_i}{\partial t}. \quad (5.61)$$

In vector notation we have

$$\frac{d\mathbf{u}}{dt} = (\mathbf{u} \cdot \nabla) \mathbf{u} + \frac{\partial \mathbf{u}}{\partial t}. \quad (5.62)$$

Newton's second law eq. (5.59) now becomes

$$\rho (\mathbf{u} \cdot \nabla) \mathbf{u} + \rho \frac{\partial \mathbf{u}}{\partial t} = -\nabla p + \mu \nabla^2 \mathbf{u} + \mu \nabla(\nabla \cdot \mathbf{u}) + \rho \mathbf{f}. \quad (5.63)$$

This is the Navier-Stokes equation. Observe that we have an explicitly non-linear term

$$(\mathbf{u} \cdot \nabla) \mathbf{u}, \quad (5.64)$$

something we do not encounter in most classical mechanics. The impacts of this non-linear term are very significant and produce some interesting effects.

5.10 INCOMPRESSIBLE FLUIDS.

We have seen that incompressibility was equivalent to

$$\nabla \cdot \mathbf{u} = 0. \quad (5.65)$$

With such a restriction the Navier-Stokes equation takes the much simpler form

$$\rho(\mathbf{u} \cdot \nabla)\mathbf{u} + \rho \frac{\partial \mathbf{u}}{\partial t} = -\nabla p + \mu \nabla^2 \mathbf{u} + \rho \mathbf{f}, \quad \nabla \cdot \mathbf{u} = 0. \quad (5.66)$$

We will not treat compressible fluids in this course.

5.11 BOUNDARY VALUE CONDITIONS.

In order to solve any sort of PDE we need to consider the boundary value conditions. Consider the interface between two layers of liquids as in fig. 5.3 Also found an illustration of this in fig 1.13 of

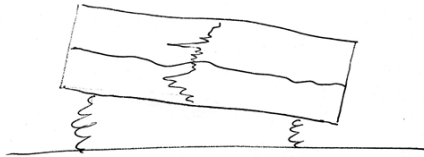

Figure 5.3: Rocker tank with two viscosity fluids.

White's text online

We see the fluids sticking together at the boundary. This is due to matching of the tangential velocity components at the interface.

5.12 NORMALS AND TANGENTS AT FLUID INTERFACES.

We watched a video of the rocking tank as in fig. 5.4. The boundary condition that accounted for the matching of the dye marker is that we have no slipping at the interface. Writing $\hat{\tau}$ for the unit tangent to the interface then this condition at the interface is described mathematically by the conditions

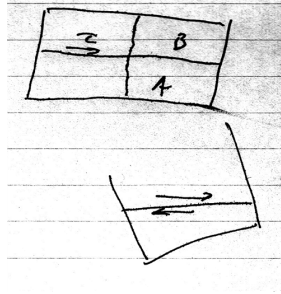

Figure 5.4: Rocking tank velocity matching.

$$\begin{aligned} \mathbf{u}_A \cdot \hat{\boldsymbol{\tau}} &= \mathbf{u}_B \cdot \hat{\boldsymbol{\tau}} \\ \mathbf{u}_A \cdot \hat{\mathbf{n}} &= \mathbf{u}_B \cdot \hat{\mathbf{n}}. \end{aligned} \tag{5.67}$$

Referring to fig. 5.5 where the tangents and normals are depicted an example representation of the normal and tangent vectors for the fluids are

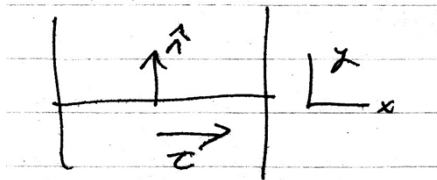

Figure 5.5: Normals and tangents at interface for 2D system.

$$\hat{\boldsymbol{\tau}} = \begin{bmatrix} 1 \\ 0 \end{bmatrix}, \quad \hat{\mathbf{n}} = \begin{bmatrix} 0 \\ 1 \end{bmatrix}. \tag{5.68}$$

For the traction vector with components

$$T_i = \sigma_{ij}n_j, \tag{5.69}$$

we also have at the interface we must have matching of

$$\hat{\boldsymbol{\tau}} \cdot \mathbf{T}. \tag{5.70}$$

More explicitly, in coordinates this is

$$\tau_i(\sigma_{ij}n_j)|_A = \tau_i(\sigma_{ij}n_j)|_B \tag{5.71}$$

Example 5.1: Steady incompressible flow.

For steady incompressible rectilinear (unidirectional) flow, we can fix our axis so that

$$\mathbf{u} = \hat{x}u(x, y, z, t), \quad (5.72)$$

where the velocity components in the other directions

$$\begin{aligned} v &= 0 \\ w &= 0, \end{aligned} \quad (5.73)$$

are both zero. Symbolically, the steady state condition is

$$\frac{\partial \mathbf{u}}{\partial t} = 0. \quad (5.74)$$

We start with the incompressibility condition, which written explicitly, is

$$\nabla \cdot \mathbf{u} = 0, \quad (5.75)$$

or

$$\frac{\partial u}{\partial x} + \frac{\partial v}{\partial y} + \frac{\partial w}{\partial z} = 0. \quad (5.76)$$

This implies

$$\frac{\partial u}{\partial x} = 0, \quad (5.77)$$

so our velocity can only be function of the y and z coordinates only

$$u = u(y, z). \quad (5.78)$$

The non-linear term of the Navier-Stokes equation takes the form

$$\begin{aligned} (\mathbf{u} \cdot \nabla)\mathbf{u} &= \left(u \frac{\partial}{\partial x} + v \frac{\partial}{\partial y} + w \frac{\partial}{\partial z} \right) (\hat{\mathbf{x}}u(y, z) + \hat{\mathbf{y}}v + \hat{\mathbf{z}}w) \\ &= \hat{\mathbf{x}}u \frac{\partial u}{\partial x} \\ &= 0. \end{aligned} \tag{5.79}$$

With incompressibility and $u = v = 0$ conditions killing this term, and the steady state condition eq. (5.74) killing the $\rho \partial \mathbf{u} / \partial t$ term, the Navier-Stokes equation for this incompressible unidirectional steady state flow (in the absence of body forces) is reduced to

$$0 = -\nabla p + \mu \nabla^2 \mathbf{u}. \tag{5.80}$$

In coordinates this is

$$\frac{\partial p}{\partial x} = \mu \left(\frac{\partial^2 u}{\partial y^2} + \frac{\partial^2 u}{\partial z^2} \right) \tag{5.81a}$$

$$\frac{\partial p}{\partial y} = 0 \tag{5.81b}$$

$$\frac{\partial p}{\partial z} = 0. \tag{5.81c}$$

Operating on the first with an x partial we find

$$\frac{\partial^2 p}{\partial x^2} = \mu \left(\frac{\partial^2}{\partial y^2} \frac{\partial u}{\partial x} + \frac{\partial^2}{\partial z^2} \frac{\partial u}{\partial x} \right) = 0. \tag{5.82}$$

Since we have

$$\frac{\partial^2 p}{\partial x^2} = 0, \tag{5.83}$$

we also have

$$\frac{d^2 p}{dx^2} = 0, \quad (5.84)$$

so our pressure must be linear with position

$$p = Ax + B, \quad (5.85)$$

as illustrated in fig. 5.6

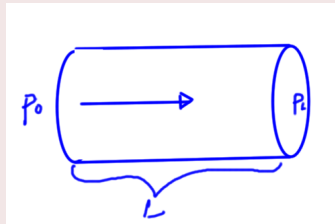

Figure 5.6: Pressure gradient in 1D system.

The pressure is

$$p = \begin{cases} p_0 & x = 0 \\ p_L & x = L, \end{cases} \quad (5.86)$$

so

$$p = \frac{p_L - p_0}{L}x + p_0, \quad (5.87)$$

and

$$\frac{dp}{dx} = \frac{p_L - p_0}{L} = \text{constant} \equiv -G. \quad (5.88)$$

Example 5.2: Shearing flow.

The flows of this sort do not have to be trivial. For example, even with constant pressure ($p_0 = p_L$) as in fig. 5.7 we can have a “shearing flow” where the fluids at the top surface are not necessarily moving at the same rates as the fluid below that surface. We have fluid flow in the x direction only, and our velocity is a function only of the y coordinate.

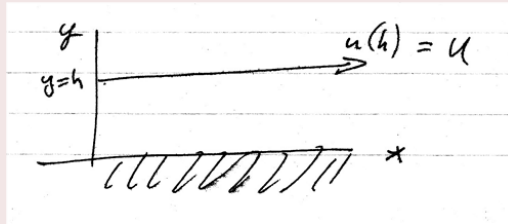

Figure 5.7: Velocity variation with height in shearing flow.

$$\begin{aligned}
 \mathbf{u} &= \hat{x}u(y) \\
 G &= 0 \\
 u(0) &= 0 \\
 u(h) &= U.
 \end{aligned}
 \tag{5.89}$$

For such a flow eq. (5.81a) simplifies to

$$\frac{d^2u}{dy^2} = 0,
 \tag{5.90}$$

with solution

$$u = \frac{U}{h}y + u(0) = \frac{U}{h}y.
 \tag{5.91}$$

Example 5.3: Channel flow.

$$\begin{aligned} \mathbf{u} &= \hat{\mathbf{x}}u(y) \\ G &= -\frac{dp}{dx} \neq 0. \end{aligned} \tag{5.92}$$

This time our simplified Navier-Stokes equation eq. (5.81a) is reduced to something slightly more complicated

$$\mu \frac{d^2u}{dy^2} = -G, \tag{5.93}$$

with solution

$$u = -\frac{G}{2\mu}y^2 + Ay + B. \tag{5.94}$$

The boundary value conditions with the coordinate system in use illustrated in fig. 5.8 require the velocity to be zero at the interface (the pipe walls preventing flow in the interior of the pipe)

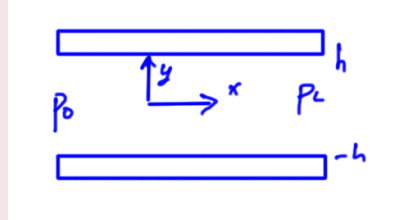

Figure 5.8: 1D Channel flow coordinate system setup.

$$u(\pm h) = -\frac{G}{2\mu}h^2 \pm Ah + B = 0. \quad (5.95)$$

One solution, immediately evident is,

$$\begin{aligned} A &= 0 \\ B &= \frac{G}{2\mu}h^2, \end{aligned} \quad (5.96)$$

so our solution becomes

$$u = \frac{G}{2\mu}(h^2 - y^2), \quad (5.97)$$

a parabolic velocity flow. This is illustrated graphically in fig. 5.9.

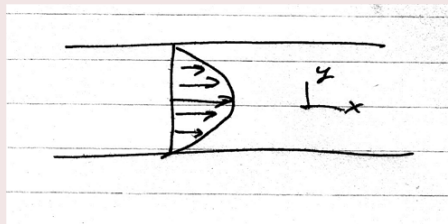

Figure 5.9: Parabolic velocity distribution.

It is clear that this is maximized by $y = 0$, but we can also see this by computing

$$\frac{du}{dy} = \frac{G}{\mu}y = 0. \quad (5.98)$$

This maximum is

$$u_{\max} = \frac{G}{2\mu}h^2. \quad (5.99)$$

The flux, or flow rate is

$$\begin{aligned} Q &= \iint_S \mathbf{u} \cdot \hat{\mathbf{x}} ds \\ &= \int_0^1 dz \int_{-h}^h dy u(y) \\ &= \frac{2Gh^3}{3}. \end{aligned} \quad (5.100)$$

Let us now compute the strain (e_{ij}) and the stress ($\sigma_{ij} = -p\delta_{ij} + 2\mu e_{ij}$)

$$\begin{aligned} e_{12} = e_{21} &= \frac{1}{2} \left(\frac{\partial u}{\partial y} \right) = -\frac{Gy}{2\mu} \\ e_{11} &= \frac{\partial u}{\partial x} = 0 \\ e_{22} &= \frac{\partial v}{\partial y} = 0, \end{aligned} \quad (5.101)$$

stress

$$\sigma_{12} = 2\mu e_{12} = -Gy. \quad (5.102)$$

This can be used to compute the forces on the inner surfaces of the tube. As illustrated in fig. 5.10, our normals at $\pm h$ are $\mp \hat{\mathbf{y}}$ respectively. The traction vector in the y direction is at $y = h$ is

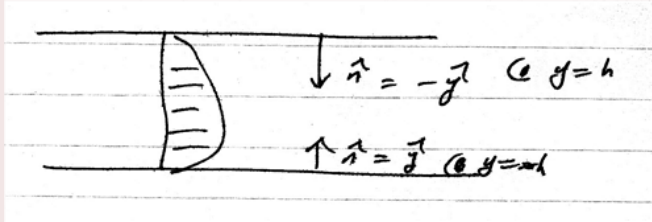

Figure 5.10: Normals in 1D channel flow system.

$$\tau_i = \sigma_{i2} n_2|_{y=h} = Gh, \quad (5.103)$$

so that

$$\tau = \hat{x}Gh. \quad (5.104)$$

Here the x directionality comes from the $i = 1$ index of the stress tensor, so the force per unit distance is

$$F_{xL} = \hat{x} \cdot \tau = Gh. \quad (5.105)$$

The total force is then

$$\int_0^L F_x dx = +GhL. \quad (5.106)$$

5.13 SOLUTIONS BY INTUITION.

Two examples that we have solved analytically are illustrated in fig. 5.11 and fig. 5.12. Sometimes we can utilize solutions already

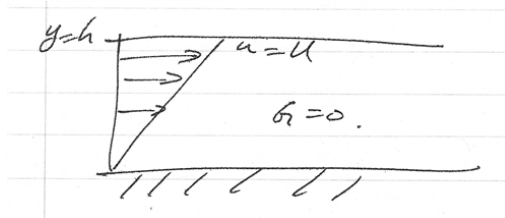

Figure 5.11: Simple shear flow.

found to understand the behavior of more complex systems. Combining the two we can look at flow over a plate as in fig. 5.13

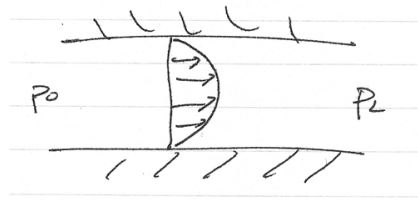

Figure 5.12: Channel flow.

Example 2. Fluid in a container. If the surface tension is altered on

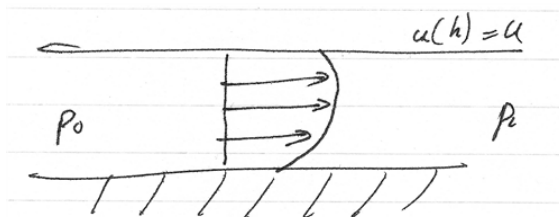

Figure 5.13: Flow on a plate.

one side, we induce a flow on the surface, leading to a circulation flow. This can be done for example, by introducing a heat source or addition of surfactant.

This is illustrated in fig. 5.14 This sort of flow is hard to analyze, only first done by Steve Davis in the 1980's. The point here is that we can use some level of intuition to guide our attempts at solution.

Example 5.4: Flow down a pipe.

Reading: §2 from [2].

Recall that the Navier-Stokes equation is

$$\rho \frac{\partial \mathbf{u}}{\partial t} + \rho(\mathbf{u} \cdot \nabla)\mathbf{u} = -\nabla p + \mu \nabla^2 \mathbf{u} + \rho \mathbf{f}. \quad (5.107)$$

We need to express this in cylindrical coordinates (r, θ, z) as in fig. 5.15

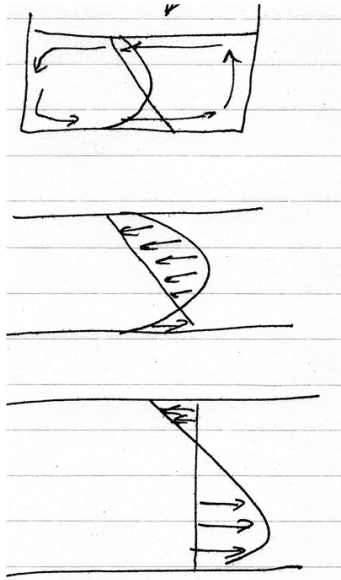

Figure 5.14: Circulation flow induced by altering surface tension.

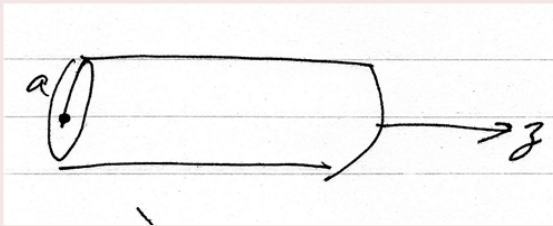

Figure 5.15: Flow through a pipe.

Our gradient is

$$\nabla = \hat{\mathbf{r}} \frac{\partial}{\partial r} + \frac{\hat{\boldsymbol{\theta}}}{r} \frac{\partial}{\partial \theta} + \hat{\mathbf{z}} \frac{\partial}{\partial z}. \quad (5.108)$$

For our Laplacian we find

$$\begin{aligned}
 \nabla^2 &= \left(\hat{\mathbf{r}} \frac{\partial}{\partial r} + \frac{\hat{\boldsymbol{\theta}}}{r} \frac{\partial}{\partial \theta} + \hat{\mathbf{z}} \frac{\partial}{\partial z} \right) \cdot \left(\hat{\mathbf{r}} \frac{\partial}{\partial r} + \frac{\hat{\boldsymbol{\theta}}}{r} \frac{\partial}{\partial \theta} + \hat{\mathbf{z}} \frac{\partial}{\partial z} \right) \\
 &= \partial_{rr} + \frac{\hat{\boldsymbol{\theta}}}{r} \cdot (\partial_\theta \hat{\mathbf{r}}) \partial_r + \frac{1}{r} \partial_\theta \left(\frac{1}{r} \partial_\theta \right) + \partial_{zz} \quad (5.109) \\
 &= \partial_{rr} + \frac{1}{r} \partial_r + \frac{1}{r^2} \partial_{\theta\theta} + \partial_{zz},
 \end{aligned}$$

which we can write as

$$\nabla^2 = \frac{1}{r} \frac{\partial}{\partial r} \left(r \frac{\partial}{\partial r} \right) + \frac{1}{r^2} \frac{\partial^2}{\partial \theta^2} + \frac{\partial^2}{\partial z^2}. \quad (5.110)$$

Navier-Stokes takes the form

$$\begin{aligned}
 \rho \frac{\partial \mathbf{u}}{\partial t} + \rho \left(u_r \frac{\partial}{\partial r} + \frac{u_\theta}{r} \frac{\partial}{\partial \theta} + u_z \frac{\partial}{\partial z} \right) \mathbf{u} = \\
 - \left(\hat{\mathbf{r}} \frac{\partial}{\partial r} + \frac{\hat{\boldsymbol{\theta}}}{r} \frac{\partial}{\partial \theta} + \hat{\mathbf{z}} \frac{\partial}{\partial z} \right) p \quad (5.111) \\
 + \mu \left(\frac{1}{r} \frac{\partial}{\partial r} \left(r \frac{\partial}{\partial r} \right) + \frac{1}{r^2} \frac{\partial^2}{\partial \theta^2} + \frac{\partial^2}{\partial z^2} \right) \mathbf{u} + \rho \mathbf{f}.
 \end{aligned}$$

It is pointed out in [2], that our non-linear term $(\mathbf{u} \cdot \nabla)\mathbf{u}$, with $\mathbf{u} = \hat{\mathbf{r}}u_r + \hat{\boldsymbol{\theta}}u_\theta + \hat{\mathbf{z}}u_z$ has contributions both from the coordinates (u_r, u_θ, u_z) and the unit vectors $\{\hat{\mathbf{r}}, \hat{\boldsymbol{\theta}}, \hat{\mathbf{z}}\}$ since both $\hat{\mathbf{r}}$ and $\hat{\boldsymbol{\theta}}$ have θ dependence. So if we wish to express Navier-Stokes in coordinate form we must write

$$\begin{aligned}
 (\mathbf{u} \cdot \nabla)\mathbf{u} &= \hat{\mathbf{r}}(\mathbf{u} \cdot \nabla)u_r + \hat{\boldsymbol{\theta}}(\mathbf{u} \cdot \nabla)u_\theta + \hat{\mathbf{z}}(\mathbf{u} \cdot \nabla)u_z + \frac{u_\theta}{r} \hat{\boldsymbol{\theta}}u_r - \frac{u_\theta}{r} \hat{\mathbf{r}}u_\theta \\
 &= \hat{\mathbf{r}} \left((\mathbf{u} \cdot \nabla)u_r - \frac{u_\theta^2}{r} \right) \\
 &\quad + \hat{\boldsymbol{\theta}} \left((\mathbf{u} \cdot \nabla)u_\theta + \frac{u_r u_\theta}{r} \right) + \hat{\mathbf{z}}((\mathbf{u} \cdot \nabla)u_z). \quad (5.112)
 \end{aligned}$$

For steady state and incompressible fluids in the absence of body forces we have

$$\left(\hat{\mathbf{r}} \frac{\partial}{\partial r} + \frac{\hat{\boldsymbol{\theta}}}{r} \frac{\partial}{\partial \theta} + \hat{\mathbf{z}} \frac{\partial}{\partial z} \right) p = \mu \left(\frac{1}{r} \frac{\partial}{\partial r} \left(r \frac{\partial}{\partial r} \right) + \frac{1}{r^2} \frac{\partial^2}{\partial \theta^2} + \frac{\partial^2}{\partial z^2} \right) \mathbf{u}, \quad (5.113)$$

or, in coordinates

$$\begin{aligned} \frac{\partial p}{\partial r} &= \mu \left(\frac{1}{r} \frac{\partial}{\partial r} \left(r \frac{\partial}{\partial r} \right) + \frac{1}{r^2} \frac{\partial^2}{\partial \theta^2} + \frac{\partial^2}{\partial z^2} \right) u_r \\ \frac{1}{r} \frac{\partial p}{\partial \theta} &= \mu \left(\frac{1}{r} \frac{\partial}{\partial r} \left(r \frac{\partial}{\partial r} \right) + \frac{1}{r^2} \frac{\partial^2}{\partial \theta^2} + \frac{\partial^2}{\partial z^2} \right) u_\theta \\ \frac{\partial p}{\partial z} &= \mu \left(\frac{1}{r} \frac{\partial}{\partial r} \left(r \frac{\partial}{\partial r} \right) + \frac{1}{r^2} \frac{\partial^2}{\partial \theta^2} + \frac{\partial^2}{\partial z^2} \right) u_z. \end{aligned} \quad (5.114)$$

With an assumption that we have no radial or circulatory flows ($u_r = u_\theta = 0$), and with $u_z = w$ assumed to only have a radial dependence, our velocity is

$$\mathbf{u} = \hat{\mathbf{z}} w(r), \quad (5.115)$$

and an assumption of linear pressure dependence

$$\frac{dp}{dz} = -G, \quad (5.116)$$

then Navier-Stokes takes the final simple form

$$\frac{1}{r} \frac{d}{dr} \left(r \frac{dw}{dr} \right) = -\frac{G}{\mu}. \quad (5.117)$$

Solving this we have

$$r \frac{dw}{dr} = -\frac{Gr^2}{2\mu} + A, \quad (5.118)$$

$$w = -\frac{Gr^2}{4\mu} + A \ln(r) + B. \quad (5.119)$$

Requiring finite solutions for $r = 0$ means that we must have $A = 0$. Also $w(a) = 0$, we have $B = Ga^2/4\mu$ so we must have

$$w(r) = \frac{G}{4\mu}(a^2 - r^2). \quad (5.120)$$

Example 5.5: Gravity driven flow of a liquid film.

Reading: §2.3 from [2].

Coordinates as in fig. 5.16 are

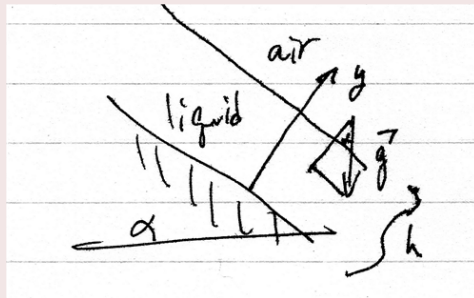

Figure 5.16: Gravity driven flow down an inclined plane.

$$\mathbf{u} = \hat{x}u(y). \quad (5.121)$$

Our boundary conditions are

1. $u(y = 0) = 0$
2. Tangential stress at the air-liquid interface $y = h$ is equal.

$$\boldsymbol{\tau} \cdot (\boldsymbol{\sigma}_l \cdot \hat{\mathbf{n}}) = \boldsymbol{\tau} \cdot (\boldsymbol{\sigma}_a \cdot \hat{\mathbf{n}}), \quad (5.122)$$

We write

$$\boldsymbol{\tau} = \begin{bmatrix} 1 \\ 0 \\ 0 \end{bmatrix}, \quad \hat{\mathbf{n}} = \begin{bmatrix} 0 \\ 1 \\ 0 \end{bmatrix}, \quad (5.123)$$

and seek simultaneous solutions to the pair of stress tensor equations

$$\begin{aligned}\sigma_{ij}^l &= -p\delta_{ij} + \mu^l \left(\frac{\partial u_i}{\partial x_j} + \frac{\partial u_j}{\partial x_i} \right) \\ \sigma_{ij}^a &= -p\delta_{ij} + \mu^a \left(\frac{\partial u_i}{\partial x_j} + \frac{\partial u_j}{\partial x_i} \right).\end{aligned}\tag{5.124}$$

In general this requires an iterated approach, solving for one with an initial approximation of the other, then switching and tuning the numerical method carefully for convergence.

We expect that the flow of liquid will induce a flow of air at the interface, but may be able to make a one-sided approximation. Let us see how far we get before we have to introduce any approximations and compute the traction vector for the liquid

$$\begin{aligned}\sigma^l \cdot \hat{\mathbf{n}} &= \begin{bmatrix} -p & \mu^l \partial u / \partial y & 0 \\ \mu^l \partial u / \partial y & -p & 0 \\ 0 & 0 & 0 \end{bmatrix} \begin{bmatrix} 0 \\ 1 \\ 0 \end{bmatrix} \\ &= \begin{bmatrix} \mu^l \partial u / \partial y \\ -p \\ 0 \end{bmatrix}\end{aligned}\tag{5.125}$$

So

$$\boldsymbol{\tau} \cdot (\sigma^l \cdot \hat{\mathbf{n}}) = \begin{bmatrix} 1 & 0 & 0 \end{bmatrix} \begin{bmatrix} \mu^l \partial u / \partial y \\ -p \\ 0 \end{bmatrix} = \mu^l \frac{\partial u}{\partial y}.\tag{5.126}$$

Our boundary value condition is therefore

$$\mu^l \frac{\partial u^l}{\partial y} \Big|_{y=h} = \mu^a \frac{\partial u^a}{\partial y} \Big|_{y=h}.\tag{5.127}$$

When can we decouple this, treating only the liquid? Observe that we have

$$\left. \frac{\partial u^l}{\partial y} \right|_{y=h} = \frac{\mu^a}{\mu^l} \left. \frac{\partial u^a}{\partial y} \right|_{y=h}, \quad (5.128)$$

so if

$$\frac{\mu_a}{\mu_l} \ll 1, \quad (5.129)$$

we can treat only the liquid portion of the problem, with a boundary value condition

$$\left. \frac{\partial u^l}{\partial y} \right|_{y=h} = 0. \quad (5.130)$$

Let us look at the component of the traction vector in the direction of the normal (liquid pressure acting on the air)

$$\hat{\mathbf{n}} \cdot (\boldsymbol{\sigma}^l \cdot \hat{\mathbf{n}}) = \hat{\mathbf{n}} \cdot (\boldsymbol{\sigma}^a \cdot \hat{\mathbf{n}}), \quad (5.131)$$

or

$$\begin{bmatrix} 0 & 1 & 0 \end{bmatrix} \begin{bmatrix} \mu^l \frac{\partial u}{\partial y} \\ -p^l \\ 0 \end{bmatrix} = -p^l \Big|_{y=h} = -p^a \Big|_{y=h}. \quad (5.132)$$

i.e. We have pressure matching at the interface. Our body force is

$$\mathbf{f} = \begin{bmatrix} g \sin \alpha \\ -g \cos \alpha \\ 0 \end{bmatrix}. \quad (5.133)$$

Referring to the Navier-Stokes equation eq. (5.107), we see that our only surviving parts are

$$0 = -\frac{\partial p}{\partial x} + \mu \frac{\partial^2 u}{\partial y^2} + \rho g \sin \alpha, \quad (5.134a)$$

$$0 = -\frac{\partial p}{\partial y} - \rho g \cos \alpha, \quad (5.134b)$$

$$0 = -\frac{\partial p}{\partial z}. \quad (5.134c)$$

The last gives us $p \neq p(z)$. Integrating the second we have

$$p = \rho g y \cos \alpha + p_1. \quad (5.135)$$

Since $p = p_{\text{atm}}$ at $y = h$, we have

$$p_{\text{atm}} = \rho g h \cos \alpha + p_1. \quad (5.136)$$

Our first Navier-Stokes equation eq. (5.134a) becomes

$$0 = \mu \frac{\partial^2 u}{\partial y^2} + \rho g \sin \alpha, \quad (5.137)$$

or

$$\frac{\partial^2 u}{\partial y^2} = -\frac{\rho g}{\mu} \sin \alpha. \quad (5.138)$$

This we integrate twice

$$u = -\rho g \frac{\sin \alpha}{2\mu} y^2 + Ay + B. \quad (5.139)$$

With

$$u(0) = 0, \quad (5.140)$$

we see that $B = 0$, and with

$$\left. \frac{\partial u}{\partial y} \right|_{y=h} = 0, \quad (5.141)$$

we find that

$$0 = -\rho g \frac{\sin \alpha}{\mu} h + A, \quad (5.142)$$

for

$$u = \rho g y \frac{\sin \alpha}{2\mu} y (2h - y). \quad (5.143)$$

This velocity distribution is illustrated fig. 5.17.

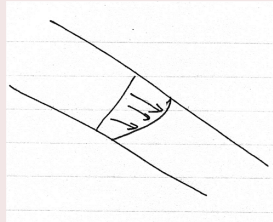

Figure 5.17: Velocity streamlines for flow down a plane.

It is important to note that in these problems we have to derive our boundary value conditions! They are not given.

In this discussion, the height h was assumed to be constant, with the tangential direction constant and parallel to the surface that the liquid is flowing on. It is claimed in class that this is actually a consequence of surface tension only!

5.14 SUMMARY.

5.14.1 *Vector displacements.*

Those portions of the theory of elasticity that we did cover have the appearance of providing some logical context for the derivation of the Navier-Stokes equation. Our starting point is almost identical, but we now look at displacements that vary with time, forming

$$d\mathbf{x}' = d\mathbf{x} + d\mathbf{u}\delta t. \quad (5.144)$$

We compute a first order Taylor expansion of this differential, defining a symmetric strain and antisymmetric vorticity tensor

$$e_{ij} = \frac{1}{2} \left(\frac{\partial u_i}{\partial x_j} + \frac{\partial u_j}{\partial x_i} \right), \quad (5.145a)$$

$$\omega_{ij} = \frac{1}{2} \left(\frac{\partial u_i}{\partial x_j} - \frac{\partial u_j}{\partial x_i} \right), \quad (5.145b)$$

allowing us to write

$$dx'_i = dx_i + e_{ij} dx_j \delta t + \omega_{ij} dx_j \delta t. \quad (5.146)$$

We introduced vector and dual vector forms of the vorticity tensor with

$$\Omega_k = \frac{1}{2} \partial_i u_j \epsilon_{ijk}, \quad (5.147a)$$

$$\omega_{ij} = -\Omega_k \epsilon_{ijk}, \quad (5.147b)$$

or

$$\boldsymbol{\omega} = \nabla \times \mathbf{u}, \quad (5.148a)$$

$$\boldsymbol{\Omega} = \frac{1}{2} (\omega)_a \mathbf{e}_a. \quad (5.148b)$$

We were then able to put our displacement differential into a partial vector form

$$d\mathbf{x}' = d\mathbf{x} + (\mathbf{e}_i (e_{ij} \mathbf{e}_j) \cdot d\mathbf{x} + \boldsymbol{\Omega} \times d\mathbf{x}) \delta t. \quad (5.149)$$

5.14.2 *Relative change in volume.*

We are able to identify the divergence of the displacement as the relative change in volume per unit time in terms of the strain tensor trace (in the basis for which the strain is diagonal at a given point)

$$\frac{dV' - dV}{dV \delta t} = \nabla \cdot \mathbf{u}. \quad (5.150)$$

5.14.3 *Conservation of mass.*

Utilizing Green's theorem we argued that

$$\int \left(\frac{\partial \rho}{\partial t} + \nabla \cdot (\rho \mathbf{u}) \right) dV = 0. \quad (5.151)$$

We were able to relate this to rate of change of density, computing

$$\frac{d\rho}{dt} = \frac{\partial \rho}{\partial t} + \mathbf{u} \cdot \nabla \rho = -\rho \nabla \cdot \mathbf{u}. \quad (5.152)$$

An important consequence of this is that for incompressible fluids (the only types of fluids considered in this course) the divergence of the displacement $\nabla \cdot \mathbf{u} = 0$.

5.14.4 *Constitutive relation.*

We consider only Newtonian fluids, for which the stress is linearly related to the strain. We will model fluids as disjoint sets of hydrostatic materials for which the constitutive relation was previously found to be

$$\sigma_{ij} = -p\delta_{ij} + 2\mu e_{ij}. \quad (5.153)$$

5.14.5 *Conservation of momentum (Navier-Stokes).*

As in elasticity, our momentum conservation equation had the form

$$\rho \frac{du_i}{dt} = \frac{\partial \sigma_{ij}}{\partial x_j} + f_i, \quad (5.154)$$

where f_i are the components of the external (body) forces per unit volume acting on the fluid.

5.14.6 *Observe the first order time derivative here.*

Note that unlike our momentum conservation equation in elasticity eq. (4.40), we have a first order time derivative on the LHS. This is because u_i is taken to be a velocity here, but was a position displacement in the elasticity review.

Utilizing the constitutive relation and explicitly evaluating the stress tensor divergence $\partial\sigma_{ij}/\partial x_j$ we find

$$\rho \frac{d\mathbf{u}}{dt} = \rho \frac{\partial\mathbf{u}}{\partial t} + \rho(\mathbf{u} \cdot \nabla)\mathbf{u} = -\nabla p + \mu \nabla^2 \mathbf{u} + \mu \nabla(\nabla \cdot \mathbf{u}) + \rho \mathbf{f}. \quad (5.155)$$

Since we treat only incompressible fluids in this course we can decompose this into a pair of equations

$$\rho \frac{\partial\mathbf{u}}{\partial t} + \rho(\mathbf{u} \cdot \nabla)\mathbf{u} = -\nabla p + \mu \nabla^2 \mathbf{u} + \rho \mathbf{f}, \quad (5.156a)$$

$$\nabla \cdot \mathbf{u} = 0. \quad (5.156b)$$

5.14.7 *No slip condition.*

We will find in general that we have to solve for our boundary value conditions. One of the important constraints that we have to do so will be a requirement (experimentally motivated) that our velocities match at an interface. This was illustrated with a rocker tank video in class.

This is the no-slip condition, and includes a requirement that the fluid velocity at the boundary of a non-moving surface is zero, and that the fluid velocity on the boundary of a moving surface matches the rate of the surface itself.

For fluids A and B separated at an interface with unit normal $\hat{\mathbf{n}}$ and unit tangent $\hat{\boldsymbol{\tau}}$ we wrote the no-slip condition as

$$\mathbf{u}_A \cdot \hat{\boldsymbol{\tau}} = \mathbf{u}_B \cdot \hat{\boldsymbol{\tau}}, \quad (5.157a)$$

$$\mathbf{u}_A \cdot \hat{\mathbf{n}} = \mathbf{u}_B \cdot \hat{\mathbf{n}}. \quad (5.157b)$$

For the problems we attempt, it will often be enough to consider only the tangential component of the velocity.

5.14.8 *Traction vector matching at an interface.*

As well as matching velocities, we have a force balance requirement at any interface. This will be expressed in terms of the traction vector

$$\boldsymbol{\tau} = \mathbf{e}_i \sigma_{ij} n_j = \boldsymbol{\sigma} \cdot \hat{\mathbf{n}}, \quad (5.158)$$

where $\hat{\mathbf{n}} = n_j \mathbf{e}_j$ is the normal pointing from the interface into the fluid (so the traction vector represents the force of the interface on the fluid). When that interface is another fluid, we are able to calculate the force of one fluid on the other.

In addition the the constraints provided by the no-slip condition, we will often have to constrain our solutions according to the equality of the tangential components of the traction vector

$$\tau_i(\sigma_{ij}n_j)|_A = \tau_i(\sigma_{ij}n_j)|_B, \quad (5.159)$$

We will sometimes also have to consider, especially when solving for the pressure, the force balance for the normal component of the traction vector at the interface too

$$n_i(\sigma_{ij}n_j)|_A = n_i(\sigma_{ij}n_j)|_B. \quad (5.160)$$

As well as having a messy non-linear PDE to start with, our boundary value constraints can be very complicated, making the subject rich and tricky.

5.14.9 Flux.

A number of problems we did asked for the flux rate. A slightly more sensible physical quantity is the mass flux, which adds the density into the mix

$$\int \frac{dm}{dt} = \rho \int \frac{dV}{dt} = \rho \int (\mathbf{u} \cdot \hat{\mathbf{n}}) dA. \quad (5.161)$$

5.15 PROBLEMS.

Exercise 5.1 Steady rectilinear blood flow. (2012 ps2)

Imagine a steady rectilinear blood flow of the form $\mathbf{u} = u(y)\hat{\mathbf{y}}$ through a two dimensional artery. It is driven by a constant pressure gradient $G = -dp/dx$ maintained by an external 'heart'. The top and bottom walls of the artery are $2h$ distance apart and the fluid satisfies no-slip boundary conditions at the walls. Assuming that the fluid is Newtonian,

- a. Show that the Navier-Stokes equation reduces to

$$\frac{d^2u}{dy^2} = -\frac{G}{\mu}, \quad (5.162)$$

where μ is the viscosity of the blood.

- b. Show that the velocity profile of the fluid inside the artery is a parabolic profile.
- c. What is the maximum speed of the fluid? Draw the velocity profile to show where the maximum speed occurs inside the artery.
- d. If due to smoking etc., the viscosity of the blood gets doubled, then what should be the new pressure gradient to be maintained by the 'heart' to keep the liquid flux through the artery at the same level as the non-smoking one?

Answer for Exercise 5.1

Solution Part a. Navier-Stokes. The Navier-Stokes equation, for an incompressible unidirectional fluid $\mathbf{u} = (u, 0, 0)$, assuming that there is no z dependence, takes the form

$$\rho \frac{\partial u}{\partial t} + u \frac{\partial u}{\partial x} = -\frac{\partial p}{\partial x} + \mu \left(\frac{\partial^2}{\partial x^2} + \frac{\partial^2}{\partial y^2} \right) u, \quad (5.163a)$$

$$0 = -\frac{\partial p}{\partial y}, \quad (5.163b)$$

$$0 = -\frac{\partial p}{\partial z}, \quad (5.163c)$$

$$0 = \frac{\partial u}{\partial x}. \quad (5.163d)$$

With a steady state assumption we kill the $\partial u/\partial t$ term, and eq. (5.163d) kills of the x -component of the Laplacian and our non-linear inertial term on the LHS, leaving just

$$0 = -\frac{\partial p}{\partial x} + \mu \frac{\partial^2 u}{\partial y^2}, \quad (5.164a)$$

$$0 = -\frac{\partial p}{\partial y'}, \quad (5.164b)$$

$$0 = -\frac{\partial p}{\partial z}. \quad (5.164c)$$

With $\frac{\partial p}{\partial z} = \frac{\partial p}{\partial y} = 0$, we have $\frac{\partial p}{\partial x} = dp/dx = -G$, so eq. (5.164a) is reduced to

$$0 = G + \mu \frac{\partial^2 u}{\partial y^2}. \quad (5.165)$$

Finally, since we have an assumption of no z-dependence ($\partial u/\partial z = 0$) and from the incompressibility assumption eq. (5.163d) ($\partial u/\partial x = 0$), we have

$$\frac{\partial^2 u}{\partial y^2} = \frac{d^2 u}{dy^2} = -\frac{G}{\mu}, \quad (5.166)$$

as desired.

Solution Part b. Velocity profile. For the velocity profile, integrating eq. (5.166) twice, we have

$$u = -\frac{G}{2\mu}y^2 + Ay + B. \quad (5.167)$$

Application of the no-slip boundary value condition $u(\pm h) = 0$, we have

$$\begin{aligned} 0 &= -\frac{G}{2\mu}h^2 + Ah + B, \\ 0 &= -\frac{G}{2\mu}h^2 - Ah + B. \end{aligned} \quad (5.168)$$

Adding and subtracting these, we find

$$A = 0, \quad (5.169a)$$

$$B = \frac{G}{2\mu}h^2, \quad (5.169b)$$

so the velocity is given by the parabolic function

$$u(y) = \frac{G}{2\mu} (h^2 - y^2). \quad (5.170)$$

Solution Part c. *Maximum speed.* It is clear that the maximum speed of the fluid is found at $y = 0$

$$u(0) = \frac{Gh^2}{2\mu}. \quad (5.171)$$

The velocity profile for this flow is drawn in fig. 5.18.

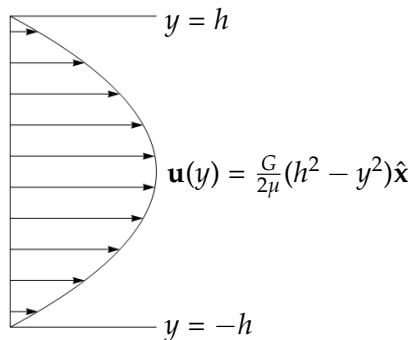

Figure 5.18: Velocity profile for 1D constant pressure gradient steady state flow.

Solution Part d. *Effects of viscosity doubling.* With our velocity being dependent on the G/μ ratio, it is clear that to consider the effects of viscosity doubling, even without calculating the flux, that we will need twice the pressure gradient if the viscosity is doubled to maintain the same flux through the artery and veins. To demonstrate this more thoroughly we can calculate this mass flux. For an element of mass leaving a portion of the conduit, bounded by the plane normal to \hat{x} we have

$$\frac{dm}{dt} = \rho \frac{dV}{dt} = \rho dz dy \mathbf{u} \cdot \hat{x}. \quad (5.172)$$

Integrating this over a width Δz , our flux through the plane is

$$\begin{aligned}
 \text{Flux} &= \int_0^{\Delta z} dz \int_{-h}^h dy \frac{G}{2\mu} (h^2 - y^2) \\
 &= \Delta z \frac{G}{2\mu} \left(h^2 y - \frac{1}{3} y^3 \right) \Big|_{-h}^h \\
 &= \Delta z \frac{Gh^3}{\mu} \left(1 - \frac{1}{3} \right) \\
 &= \Delta z \frac{2Gh^3}{3\mu}.
 \end{aligned} \tag{5.173}$$

Doubling the blood viscosity for our smoker, our respective fluxes are

$$\begin{aligned}
 \text{Flux}_{\text{smoker}} &= \Delta z \frac{2G_{\text{smoker}}h^3}{3(2\mu)} \\
 \text{Flux}_{\text{non-smoker}} &= \Delta z \frac{2Gh^3}{3\mu}.
 \end{aligned} \tag{5.174}$$

Demanding equality before and after smoking we find

$$G_{\text{smoker}} = 2G. \tag{5.175}$$

where G is the magnitude of the pressure gradient before the bad habits kicked in. The smoker's poor little heart (soon to be a big overworked and weak heart) has to generate pressure gradients that are twice as big to get the same quantity of blood distributed through the body.

Exercise 5.2 Simple shearing flow. (2012 ps2)

Consider steady simple shearing flow with no imposed pressure gradient ($G = 0$) of a two layer fluid with viscosity

$$\mu = \begin{cases} \mu^{(1)} & -h < y < 0, \\ \mu^{(2)} & 0 < y < h. \end{cases} \tag{5.176}$$

The boundary conditions are no-slip at the lower plate ($y = -h$) and at $y = 0$. The top plate is moving with a velocity $-U$ at $y = h$ and fluid is sticking to it. using the continuity of tangential (shear) stress at the interface ($y = 0$)

- Derive the velocity profile of the two fluids.
- Calculate the maximum speed.
- Calculate the mean speed.
- Calculate the flux (the volume flow rate.).
- Calculate the tangential force (per unit width) F_x on the strip $0 \leq x \leq L$ of the wall $y = -h$.
- Calculate the tangential force (per unit width) F_x^0 on the strip $0 \leq x \leq L$ at the interface $y = 0$ by the top fluid on the lower fluid.

Answer for Exercise 5.2

Solution Part a. Velocity profiles. Starting with the velocity profile derivation for the two fluids, we set up coordinates as in fig. 5.19. Our steady flow for layers 1 and 2 has the form

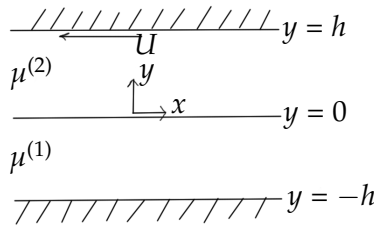

Figure 5.19: Two layer flow induced by moving wall.

$$0 = -\frac{\partial p}{\partial x} + \mu^{(i)} \frac{\partial^2 u^{(i)}}{\partial y^2}, \quad (5.177a)$$

$$0 = -\frac{\partial p}{\partial y}, \quad (5.177b)$$

$$0 = -\frac{\partial p}{\partial z}, \quad (5.177c)$$

as we found in Q1. Only the boundary value conditions and the driving pressure are different here. In this problem and the next, we have constant pressure gradients $dp/dx = -G$ to deal with, so we really have just the pair of equations

$$0 = G + \mu^{(i)} \frac{d^2 u^{(i)}(y)}{dy^2}, \quad (5.178)$$

to solve. For this Q2 problem we have $G = 0$, so the algebra to match our boundary value constraints becomes a bit easier. Our boundary value constraints are

$$u^{(1)}(-h) = 0, \quad (5.179a)$$

$$u^{(2)}(h) = -U, \quad (5.179b)$$

$$u^{(1)}(0) = u^{(2)}(0), \quad (5.179c)$$

plus one more to match the tangential components of the traction vector with respect to the normal $\hat{\mathbf{n}} = (0, 1, 0)$. The components of that traction vector are

$$\begin{aligned} t_i &= (-p\delta_{ij} + 2\mu e_{ij}) n_j \\ &= (-p\delta_{ij} + 2\mu e_{ij}) \delta_{2j} \\ &= -p\delta_{i2} + 2\mu e_{i2}, \end{aligned} \quad (5.180)$$

but we are only interested in the horizontal component t_1 which is

$$\begin{aligned} t_1 &= -p\delta_{12} + 2\mu e_{12} \\ &= 2\mu \frac{1}{2} \left(\frac{\partial y}{\partial u} + \frac{\partial x}{\partial v} \right). \end{aligned} \quad (5.181)$$

So the matching the tangential components of the traction vector at the interface gives us our last boundary value constraint

$$\mu^{(1)} \frac{\partial y}{\partial u} \Big|_{y=0} = \mu^{(2)} \frac{\partial y}{\partial u} \Big|_{y=0}, \quad (5.182)$$

and we are ready to do our remaining bits of algebra. We wish to solve the pair of equations

$$\begin{aligned} u^{(1)} &= A^{(1)}y + B^{(1)} \\ u^{(2)} &= A^{(2)}y + B^{(2)}, \end{aligned} \quad (5.183)$$

for the four integration constants $A^{(i)}$ and $B^{(i)}$ using our boundary value constraints. The linear system to solve is

$$\begin{aligned} 0 &= -A^{(1)}h + B^{(1)} \\ -U &= A^{(2)}h + B^{(2)} \\ B^{(1)} &= B^{(2)} \\ \mu^{(1)}A^{(1)} &= \mu^{(2)}A^{(2)}. \end{aligned} \quad (5.184)$$

With $B = B^{(i)}$, we have

$$\begin{aligned} 0 &= -A^{(1)}h + B \\ -U &= \frac{\mu^{(1)}}{\mu^{(2)}} A^{(1)}h + B. \end{aligned} \quad (5.185)$$

Subtracting these to solve for $A^{(1)}$ we find

$$-U = hA^{(1)} \left(\frac{\mu^{(1)}}{\mu^{(2)}} + 1 \right). \quad (5.186)$$

This gives us everything we need

$$\begin{aligned} A^{(1)} &= -\frac{U\mu^{(2)}}{h(\mu^{(1)} + \mu^{(2)})} \\ A^{(2)} &= -\frac{U\mu^{(1)}}{h(\mu^{(1)} + \mu^{(2)})} \\ B^{(1)} = B^{(2)} &= -\frac{U\mu^{(2)}}{\mu^{(1)} + \mu^{(2)}}, \end{aligned} \quad (5.187)$$

Referring back to eq. (5.183) our velocities are

$$\begin{aligned} u^{(1)} &= -\frac{U\mu^{(2)}}{(\mu^{(1)} + \mu^{(2)})} \left(1 + \frac{y}{h} \right) \\ u^{(2)} &= -\frac{U\mu^{(1)}}{(\mu^{(1)} + \mu^{(2)})} \left(1 + \frac{\mu^{(1)} y}{\mu^{(2)} h} \right). \end{aligned} \quad (5.188)$$

Checking, we see at a glance we see that we have $u^{(2)}(h) = -U$, $u^{(1)}(-h) = 0$, $u^{(1)}(0) = u^{(2)}(0)$, and $\mu^{(1)} du^{(1)}/dy|_{y=0} = \mu^{(2)} du^{(2)}/dy|_{y=0}$ as desired.

As an example, let us add some numbers. With mercury and water in layers (1) and (2) respectively, we have

$$\begin{aligned} \mu^{(1)} &= 0.001526 \text{ Pa-s} \\ \mu^{(2)} &= 0.00089 \text{ Pa-s}, \end{aligned} \quad (5.189)$$

so that our velocity is

$$u(y) = \begin{cases} -1.37U \left(1 + \frac{y}{h} \right) & y \in [-h, 0] \\ -1.37U \left(1 + 1.7\frac{y}{h} \right) & y \in [0, h]. \end{cases} \quad (5.190)$$

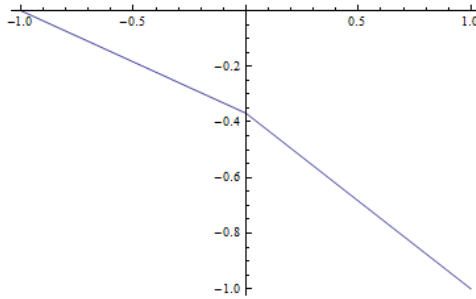

Figure 5.20: Two layer shearing flow with water over mercury.

This is plotted with $h = U = 1$ in fig. 5.20

Solution Part b. Maximum speed. We are now ready to calculate the maximum speed.

With $u^{(1)}(-h) = 0$, and $u^{(1)}$ linearly decreasing, then $u^{(2)}$ linearly decreasing further from the value at $y = 0$, it is clear that the maximum speed, no matter the viscosities of the fluids, is on the upper moving interface. This maximum takes the value $|u^{(2)}(h)| = U$.

Solution Part c. Mean speed. As linear functions the average speeds of the respective fluids fall on the midpoints $y = \pm h/2$. These are

$$\begin{aligned} \langle u^{(1)} \rangle &= -\frac{U\mu^{(2)}}{2(\mu^{(1)} + \mu^{(2)})} \\ \langle u^{(2)} \rangle &= -\frac{U\mu^{(2)}}{(\mu^{(1)} + \mu^{(2)})} \left(1 + \frac{\mu^{(1)}}{2\mu^{(2)}} \right). \end{aligned} \quad (5.191)$$

Averaging these two gives us the overall average, so we find

$$\langle u(y) \rangle = -\frac{U}{4(\mu^{(1)} + \mu^{(2)})} \left(3\mu^{(2)} + \mu^{(1)} \right). \quad (5.192)$$

Solution Part d. Volume flux. We can calculate the volume flux, much like the mass flux (although the mass flux seems a more sensible quantity to calculate). Looking at the rate of change of an element of fluid passing through the $y - z$ plane we have

$$\frac{dV}{dt} = dydz\mathbf{u} \cdot \hat{\mathbf{x}}. \quad (5.193)$$

Integrating over the total height, for a width Δz we have

$$\begin{aligned}\text{Volume Flux} &= \Delta z \int_{-h}^h u(y) dy \\ &= \Delta z 2h \langle u \rangle.\end{aligned}\tag{5.194}$$

So our volume flux through a width Δz is

$$\text{Volume Flux} = -\frac{2hU\Delta z}{4(\mu^{(1)} + \mu^{(2)})} \left(3\mu^{(2)} + \mu^{(1)} \right).\tag{5.195}$$

Solution Part e. *Tangential force on lower wall.* We see from eq. (5.188) the tangential components of our traction vectors are

$$\begin{aligned}t^{(1)} &= \mu^{(1)} \frac{du^{(1)}}{dy} \\ &= -\frac{U\mu^{(1)}\mu^{(2)}}{(\mu^{(1)} + \mu^{(2)})} \frac{1}{h},\end{aligned}\tag{5.196}$$

and

$$\begin{aligned}t^{(2)} &= \mu^{(2)} \frac{du^{(2)}}{dy} \\ &= -\frac{U\mu^{(1)}\mu^{(2)}}{(\mu^{(1)} + \mu^{(2)})} \frac{1}{h}.\end{aligned}\tag{5.197}$$

We see that the tangential component of the traction vector is a constant throughout both fluids. Allowing this force to act on a length L of the lower wall, our force per unit width over that strip is just

$$F = -\frac{U\mu^{(1)}\mu^{(2)}}{(\mu^{(1)} + \mu^{(2)})} \frac{L}{h}.\tag{5.198}$$

The negative value here makes sense since it is acting to push the fluid backwards in the direction of the upper wall motion.

Solution Part f. *Tangential force on upper wall.* We note that due to constant nature of the tangential component of the traction vector shown above, the force per unit width of the upper fluid acting on the lower fluid, is also given by eq. (5.198).

Exercise 5.3 Shearing flow, w/ pressure gradient. (2012 ps2)

Add a constant pressure gradient $G = -dp/dx$, applied between the boundaries $y = \pm h$, to the problem above. Describe qualitatively what type of flow profile you would expect in the steady state. Draw the velocity profiles for two cases (i) $\mu^{(1)} > \mu^{(2)}$ (ii) $\mu^{(1)} < \mu^{(2)}$. Explain your result.

Answer for Exercise 5.3

We showed earlier that the Navier-Stokes equations for this Q3 case, where G is non-zero were given by eq. (5.178), which restated is

$$0 = G + \mu^{(i)} \frac{d^2 u^{(i)}(y)}{dy^2}. \quad (5.199)$$

Our solutions will now necessarily be parabolic, of the form

$$u^{(i)}(y) = -\frac{G}{2\mu^{(i)}} y^2 + A^{(i)} y + B^{(i)}, \quad (5.200)$$

with the tangential traction vector components given by

$$t^{(i)} = -Gy + A^{(i)} \mu^{(i)}. \quad (5.201)$$

The boundary value constants become a bit messier to solve for, and should we wish to do so we would have to solve the system

$$\begin{aligned} 0 &= -\frac{G}{2\mu^{(1)}} h^2 - A^{(1)} h + B^{(1)} \\ -U &= -\frac{G}{2\mu^{(2)}} h^2 + A^{(2)} h + B^{(2)} \\ B^{(1)} &= B^{(2)} \\ A^{(1)} \mu^{(1)} &= A^{(2)} \mu^{(2)}. \end{aligned} \quad (5.202)$$

Without actually solving this system we should expect that our solution will have the form of our pure shear flow, with parabolas superimposed on these linear flows. For a higher viscosity bottom layer $\mu^{(1)} > \mu^{(2)}$, this should look something like fig. 5.21 whereas for the higher viscosity on the top, these would be roughly flipped as in fig. 5.22. This superposition can be justified since we have no $(\mathbf{u} \cdot \nabla) \mathbf{u}$ term in the Navier-Stokes equations for these systems.

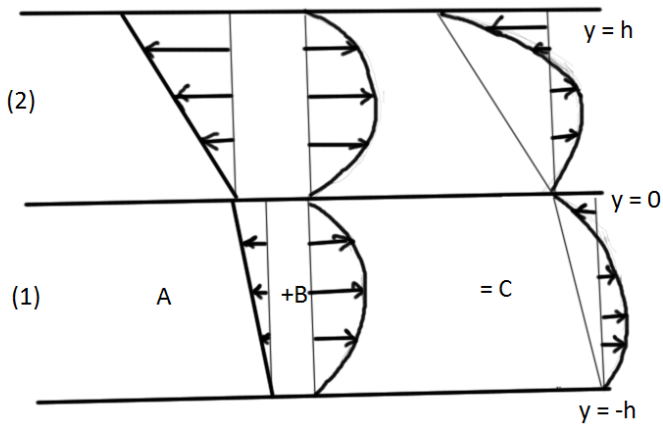

Figure 5.21: Superposition of constant pressure gradient and shear flow solutions ($\mu^{(1)} > \mu^{(2)}$).

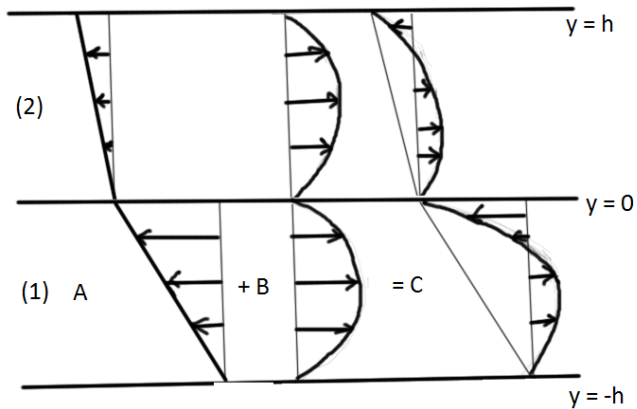

Figure 5.22: Superposition of constant pressure gradient and shear flow solutions ($\mu^{(1)} < \mu^{(2)}$).

The figures above are kind of rough. It is not actually hard to solve the system above. After some simplification, I find using Mathematica in ([problemSetIIQ3exactSolution.cdf](#)) the following solution

$$\begin{aligned} u^{(1)}(y) &= -\frac{\mu^{(2)}U - Gh^2}{\mu^{(1)} + \mu^{(2)}} - \frac{y(Gh^2(\mu^{(2)} - \mu^{(1)}) + 2\mu^{(1)}\mu^{(2)}U)}{2h\mu^{(1)}(\mu^{(1)} + \mu^{(2)})} - \frac{Gy^2}{2\mu^{(1)}} \\ u^{(2)}(y) &= -\frac{\mu^{(2)}U - Gh^2}{\mu^{(1)} + \mu^{(2)}} - \frac{y(Gh^2(\mu^{(2)} - \mu^{(1)}) + 2\mu^{(1)}\mu^{(2)}U)}{2h\mu^{(2)}(\mu^{(1)} + \mu^{(2)})} - \frac{Gy^2}{2\mu^{(2)}}. \end{aligned} \quad (5.203)$$

Should we wish a more exact plot for any specific values of the viscosities, we could plot exactly with software the vector field described by these velocities.

I suppose it is cheating to use Mathematica and then say that the solution is easy? To make amends for being lazy with my algebra, let us show that it is easy to do manually too. I will do the same problem manually, but generalize it slightly. We can do this easily if we just be a bit smarter with our integration constants. Let us solve the problem for the upper and lower walls moving with velocity V_2 and V_1 respectively, and let the heights from the interface be h_2 and h_1 respectively.

We have the same set of differential equations to solve, but now let us write our solution with the undetermined coefficients expressed as

$$\begin{aligned} u^{(2)} &= -\frac{G}{2\mu^{(2)}}(h_2^2 - y^2) + \frac{A_2}{\mu^{(2)}}(y - h_2) + B_2 \\ u^{(1)} &= -\frac{G}{2\mu^{(1)}}(h_1^2 - y^2) + \frac{A_1}{\mu^{(1)}}(y + h_1) + B_1. \end{aligned} \quad (5.204)$$

Now it is super easy to match the boundary conditions at $y = -h_1$ and $y = h_2$ (the lower and upper walls respectively). Clearly the integration constants B_1, B_2 are just the velocities. Matching the tangential component of the traction vectors at $y = 0$ we have

$$A_2 = A_1, \quad (5.205)$$

and matching velocities at $y = 0$ gives us

$$-\frac{G}{2\mu^{(2)}}h_2^2 - \frac{A_2}{\mu^{(2)}}h_2 + V_2 = -\frac{G}{2\mu^{(1)}}h_1^2 + \frac{A_1}{\mu^{(1)}}h_1 + V_1. \quad (5.206)$$

This gives us

$$\begin{aligned}
 u^{(2)} &= \frac{Gh_2^2}{2\mu^{(2)}} \left(\frac{y^2}{h_2^2} - 1 \right) + A \frac{h_2}{\mu^{(2)}} \left(\frac{y}{h_2} - 1 \right) + V_2 \\
 u^{(1)} &= \frac{Gh_1^2}{2\mu^{(1)}} \left(\frac{y^2}{h_1^2} - 1 \right) + A \frac{h_1}{\mu^{(1)}} \left(\frac{y}{h_1} + 1 \right) + V_1 \\
 A &= \frac{V_2 - V_1 + \frac{Gh_1^2}{2\mu^{(1)}} - \frac{Gh_2^2}{2\mu^{(2)}}}{\frac{h_1}{\mu^{(1)}} + \frac{h_2}{\mu^{(2)}}}.
 \end{aligned} \tag{5.207}$$

Plotting this with sliders or animation in Mathematica ([problem-SetIIQ3PlotWithManipulate.cdf](#)) is a fun way to explore visualizing this. The results vary widely depending on the various parameters. Here are animations with variation of the pressure gradient for $v_1 = 0$, $h_1 = h_2$, showing the superposition of the shear and channel flow solutions

- With $\mu^{(1)} > \mu^{(2)}$. See <http://youtu.be/2xVoFAL9XGA>.
- With $\mu^{(2)} > \mu^{(1)}$. See <http://youtu.be/FJekyGf6XJw>.

I lost a couple of marks on this assignment, all on the hand plotting. The remarks were

1. Gradients are the wrong way around.
2. G is constant across the fluid.

I am assuming that the comment about G being constant across the fluid means that the two humped velocity distribution I drew is not realistic. Here is two actual plots using the above calculations.

It was not clear to me initially what the grader meant by the gradients were the wrong way around, but I see that too looking at the actual plots. If you check out the Mathematica worksheet itself you will see that I do not have a pressure gradient slider, but a velocity V_{pressure} slider. This was based on the fact that for a channel flow our average speed is proportional to the pressure gradient

$$\langle u \rangle = \frac{Gh}{3\mu}, \tag{5.208}$$

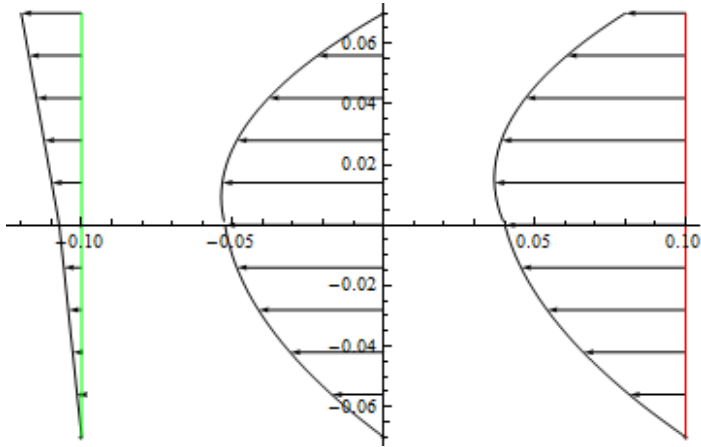

Figure 5.23: $\mu^{(1)} > \mu^{(2)}$.

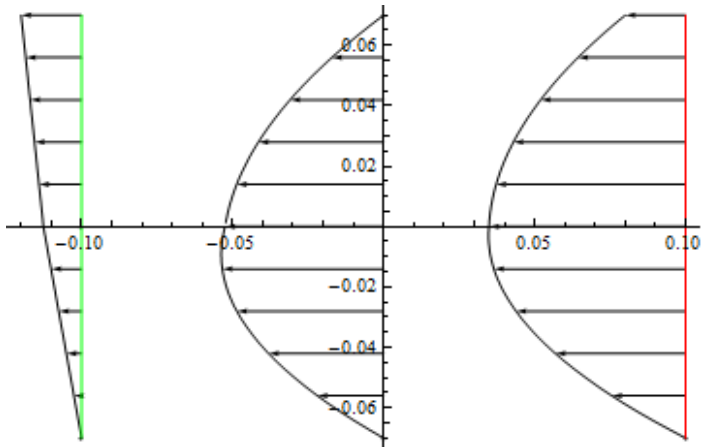

Figure 5.24: $\mu^{(2)} > \mu^{(1)}$.

so in order to parameterize the pressure gradient in an intuitive sense I defined it as a weighted average

$$G = 3V_{\text{pressure}} \frac{1}{2} \left(\frac{\mu^{(1)}}{h_1} + \frac{\mu^{(2)}}{h_2} \right). \quad (5.209)$$

Sure enough when I set $V_{\text{pressure}} > 0$ in the Mathematica slider (so that the pressure gradient is also positive) I get the channel flows pointing in the opposite direction as indicated in the grading comment. I should have sketched this channel flow more carefully in the very simplest case first before doing the two layer flow.

Exercise 5.4 **Non-Newtonian fluid. (2012 midterm, p1 c)**

What is the definition of a Non-Newtonian fluid?

Answer for Exercise 5.4

A non-Newtonian fluid would be one with a more general constitutive relationship.

A Newtonian fluid [18] is one with a linear stress strain relationship, and a non-Newtonian fluid would be one with a non-linear relationship. An example of a non-Newtonian material that we are all familiar with is Silly Putty.

Exercise 5.5 **No-slip boundary condition. (2012 midterm, p1 d)**

What do you mean by *no-slip* boundary condition at a fluid-fluid interface?

Answer for Exercise 5.5

The no slip boundary condition is just one of velocity matching. At a non-moving boundary, the no-slip condition means that we will require the fluid to also have no velocity (ie. at that interface the fluid is not slipping over the surface). Between two fluids, this is a requirement that the velocities of both fluids match at that point (and all the rest of the points along the region of the interaction.)

Exercise 5.6 **Continuity equation. (2012 midterm, p1 e)**

Write down the continuity equation for an incompressible fluid.

Answer for Exercise 5.6

An incompressible fluid has

$$\frac{d\rho}{dt} = 0, \quad (5.210)$$

but since we also have

$$\begin{aligned}
 0 &= \frac{d\rho}{dt} \\
 &= -\rho(\nabla \cdot \mathbf{u}) \\
 &= \frac{\partial\rho}{\partial t} + (\mathbf{u} \cdot \nabla)\rho \\
 &= 0.
 \end{aligned} \tag{5.211}$$

A consequence is that $\nabla \cdot \mathbf{u} = 0$ for an incompressible fluid. Let us recall where this statement comes from. Looking at mass conservation, the rate that mass leaves a volume can be expressed as

$$\begin{aligned}
 \frac{dm}{dt} &= \int \frac{d\rho}{dt} dV \\
 &= - \int_{\partial V} \rho \mathbf{u} \cdot d\mathbf{A} \\
 &= - \int_V \nabla \cdot (\rho \mathbf{u}) dV.
 \end{aligned} \tag{5.212}$$

The minus sign here signifying that the mass is leaving the volume through the surface, and that we are using an outwards facing normal on the volume. If the surface bounding the volume does not change with time (ie. $\partial V/\partial t = 0$) we can write

$$\frac{\partial}{\partial t} \int \rho dV = - \int \nabla \cdot (\rho \mathbf{u}) dV, \tag{5.213}$$

or

$$0 = \int \left(\frac{\partial\rho}{\partial t} + \nabla \cdot (\rho \mathbf{u}) \right) dV, \tag{5.214}$$

so that in differential form we have

$$0 = \frac{\partial\rho}{\partial t} + \nabla \cdot (\rho \mathbf{u}). \tag{5.215}$$

Expanding the divergence by chain rule we have

$$\frac{\partial\rho}{\partial t} + \mathbf{u} \cdot \nabla \rho = -\rho \nabla \cdot \mathbf{u}, \tag{5.216}$$

but this is just

$$\frac{d\rho}{dt} = -\rho \nabla \cdot \mathbf{u}. \tag{5.217}$$

So, for an incompressible fluid (one for which $d\rho/dt = 0$), we must also have $\nabla \cdot \mathbf{u} = 0$.

Exercise 5.7 **Steady simple shearing flow.** (2012 midterm, p2)

Consider steady simple shearing flow $\mathbf{u} = \hat{x}u(y)$ as shown in fig. 5.25 with imposed constant pressure gradient ($G = -dp/dx$), G being a positive number, of a single layer fluid with viscosity μ . The boundary conditions are no-slip at the lower plate ($y = -h$).

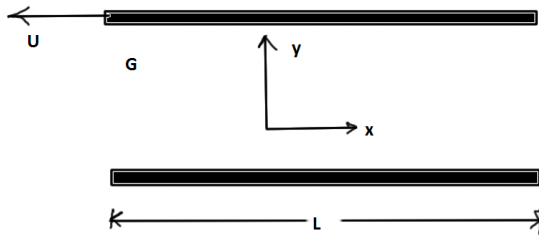

Figure 5.25: Shearing flow with pressure gradient and one moving boundary.

The top plate is moving with a velocity $-U$ at $y = h$ and fluid is sticking to it, so $u(h) = -U$, U being a positive number. Using the Navier-Stokes equation.

- Derive the velocity profile of the fluid.
- Draw the velocity profile with the direction of the flow of the fluid when $U = 0$, $G \neq 0$.
- Draw the velocity profile with the direction of the flow of the fluid when $G = 0$, $U \neq 0$.
- Using linear superposition draw the velocity profile of the fluid with the direction of flow qualitatively when $U \neq 0$, $G \neq 0$. (i) low U , (ii) large U .
- Calculate the maximum speed when $U \neq 0$, $G \neq 0$.
- Calculate the flux (the volume flow rate) when $U \neq 0$, $G \neq 0$.
- Calculate the mean speed when $U \neq 0$, $G \neq 0$.
- Calculate the tangential force (per unit width) F_x on the strip $0 \leq x \leq L$ of the wall $y = -h$ when $U \neq 0$, $G \neq 0$.

Answer for Exercise 5.7

Solution Part a. *Velocity profile.* Our equations of motion are

$$0 = \nabla \cdot \mathbf{u}, \quad (5.218a)$$

$$\rho \frac{\partial \mathbf{u}}{\partial t} + (\mathbf{u} \cdot \nabla) \mathbf{u} = -\nabla p + \mu \nabla (\nabla \cdot \mathbf{u}) + \mu \nabla^2 \mathbf{u} + \rho \mathbf{g}. \quad (5.218b)$$

Here, we have used the steady state condition and are neglecting gravity, and kill off our mass compression term with the incompressibility assumption. In component form, what we have left is

$$\begin{aligned} 0 &= \partial_x u \\ u \partial_x u &= -\partial_x p + \mu \nabla^2 u \\ 0 &= -\partial_y p \\ 0 &= -\partial_z p, \end{aligned} \quad (5.219)$$

with $\partial_y p = \partial_z p = 0$, we must have

$$\frac{\partial p}{\partial x} = \frac{dp}{dx} = -G, \quad (5.220)$$

which leaves us with just

$$\begin{aligned} 0 &= G + \mu \nabla^2 u(y) \\ &= G + \mu \frac{\partial^2 u}{\partial y^2} \\ &= G + \mu \frac{d^2 u}{dy^2}. \end{aligned} \quad (5.221)$$

Having dropped the partials we really just want to integrate our very simple ODE a couple times

$$u'' = -\frac{G}{\mu}. \quad (5.222)$$

Integrate once

$$u' = -\frac{G}{\mu} y + \frac{A}{h}, \quad (5.223)$$

and once more to find the velocity

$$u = -\frac{G}{2\mu}y^2 + \frac{A}{h}y + B'. \quad (5.224)$$

Let us incorporate an additional constant into B'

$$B' = \frac{G}{2\mu}h^2 + B, \quad (5.225)$$

so that we have

$$u = \frac{G}{2\mu}(h^2 - y^2) + \frac{A}{h}y + B. \quad (5.226)$$

(I did not do use B' this way on the exam, nor did I include the factor of $1/h$ in the first integration constant, but both of these should simplify the algebra since we will be evaluating the boundary value conditions at $y = \pm h$.)

$$u = \frac{G}{2\mu}(h^2 - y^2) + \frac{A}{h}y + B. \quad (5.227)$$

Applying the velocity matching conditions we have for the lower and upper plates respectively

$$\begin{aligned} 0 &= \frac{A}{h}(-h) + B \\ -U &= \frac{A}{h}(h) + B. \end{aligned} \quad (5.228)$$

Adding these we find

$$B = -\frac{U}{2}, \quad (5.229)$$

and subtracting find

$$A = -\frac{U}{2}. \quad (5.230)$$

Our velocity is

$$u = \frac{G}{2\mu}(h^2 - y^2) - \frac{U}{2h}y - \frac{U}{2}, \quad (5.231)$$

or rearranged a bit

$$u(y) = \frac{G}{2\mu}(h^2 - y^2) - \frac{U}{2} \left(1 + \frac{y}{h}\right). \quad (5.232)$$

Solution Part b. Zero shear. With $U = 0$ our velocity has a simple parabolic profile with a max of $\frac{G}{2\mu}(h^2 - y^2)$ at $y = 0$

$$u(y) = \frac{G}{2\mu}(h^2 - y^2). \quad (5.233)$$

This is plotted in fig. 5.26

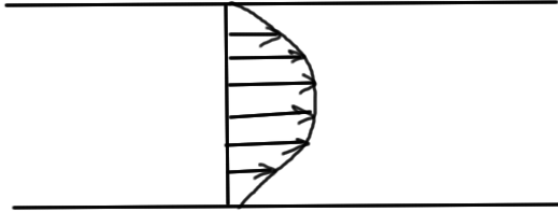

Figure 5.26: Parabolic velocity profile.

Solution Part c. Zero pressure gradient. With $G = 0$, we have a plain old shear flow

$$u(y) = -\frac{U}{2} \left(1 + \frac{y}{h}\right). \quad (5.234)$$

This is linear with minimum velocity $u = 0$ at $y = -h$, and a maximum of $-U$ at $y = h$. This is plotted in fig. 5.27

Solution Part d. Qualitative sketches.

For low U we will let the parabolic dominate, and can graphically add these two as in fig. 5.28 For high U , we will let the shear flow dominate, and have plotted this in fig. 5.29

Solution Part e. Maximum speed. Since our acceleration is

$$\frac{du}{dy} = -\frac{G}{\mu}y - \frac{U}{2h}, \quad (5.235)$$

our extreme values occur at

$$y_m = -\frac{U\mu}{2hG}. \quad (5.236)$$

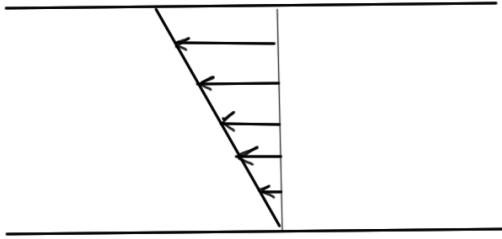

Figure 5.27: Shear flow.

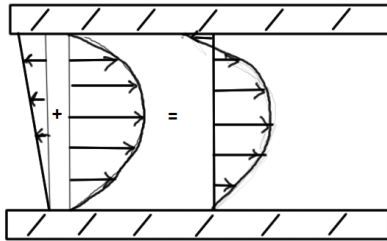

Figure 5.28: Superposition of shear and parabolic flow (low U).

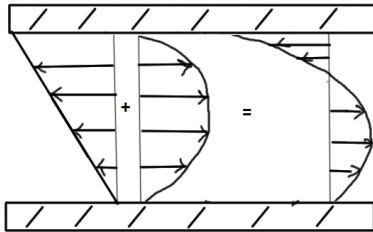

Figure 5.29: Superposition of shear and parabolic flow (high U).

At this point, our velocity is

$$\begin{aligned} u(y_m) &= \frac{G}{2\mu} \left(h^2 - \left(\frac{U\mu}{2hG} \right)^2 \right) - \frac{U}{2} \left(1 - \frac{U\mu}{2h^2G} \right) \\ &= \frac{Gh^2}{2\mu} - \frac{U}{2} + \frac{U^2\mu}{4h^2G} \left(1 - \frac{1}{2} \right), \end{aligned} \quad (5.237)$$

or just

$$u_{\max} = \frac{Gh^2}{2\mu} - \frac{U}{2} + \frac{U^2\mu}{8h^2G}. \quad (5.238)$$

Solution Part f. Volume flow rate. An element of our volume flux is

$$\frac{dV}{dt} = dydz \mathbf{u} \cdot \hat{\mathbf{x}}. \quad (5.239)$$

Looking at the volume flux through the width Δz is then

$$\begin{aligned} \text{Flux} &= \int_0^{\Delta z} dz \int_{-h}^h dy u(y) \\ &= \Delta z \int_{-h}^h dy \frac{G}{2\mu} (h^2 - y^2) - \frac{U}{2} \left(1 + \frac{y}{h} \right) \\ &= \Delta z \int_{-h}^h dy \frac{G}{2\mu} \left(h^2 y - \frac{1}{3} y^3 \right) - \frac{U}{2} \left(y + \frac{y^2}{2h} \right) \\ &= \Delta z \left(\frac{2Gh^3}{3\mu} - Uh \right). \end{aligned} \quad (5.240)$$

Solution Part g. Mean speed. We have done most of the work above, and just have to divide the flux by $2h\Delta z$. That is

$$\langle u \rangle = \frac{Gh^2}{3\mu} - \frac{U}{2}. \quad (5.241)$$

Solution Part h. Tangential force on the strip. Our traction vector is

$$\begin{aligned} T_1 &= \sigma_{1j} n_j \\ &= (-p\delta_{1j} + 2\mu e_{1j}) \delta_{2j} \\ &= 2\mu e_{12} \\ &= \mu \left(\frac{\partial u}{\partial y} + \frac{\partial \varphi}{\partial x} \right). \end{aligned} \quad (5.242)$$

So the \hat{x} directed component of the traction vector is just

$$T_1 = \mu \frac{\partial u}{\partial y}. \quad (5.243)$$

We have calculated that derivative above in eq. (5.235), so we have

$$\begin{aligned} T_1 &= \mu \left(-\frac{G}{\mu}y - \frac{U}{2h} \right) \\ &= -Gy - \frac{U\mu}{2h}. \end{aligned} \quad (5.244)$$

so at $y = -h$ we have

$$T_1(-h) = Gh - \frac{U\mu}{2h}. \quad (5.245)$$

To see the contribution of this force on the lower wall over an interval of length L we integrate, but this amounts to just multiplying by the length of the segment of the wall

$$\int_0^L T_1(-h)dx = \left(Gh - \frac{U\mu}{2h} \right) L. \quad (5.246)$$

Exercise 5.8 Rectilinear flow with shear and pressure gradients.

Solve for the velocity and discuss.

Answer for Exercise 5.8

Lets specify that we have fluid flowing between surfaces at $z = \pm h$, the lower surface moving at velocity v and pressure gradient $dp/dx = -G$ we find that Navier-Stokes for an assumed flow of $\mathbf{u} = u(z)\hat{x}$ takes the form

$$0 = \partial_x u + \partial_y(0) + \partial_z(0) \quad (5.247)$$

$$u \cancel{\partial_x} \cancel{u} = -\partial_x p + \mu \partial_{zz} u \quad (5.248)$$

$$0 = -\partial_y p \quad (5.249)$$

$$0 = -\partial_z p. \quad (5.250)$$

We find that this reduces to

$$\frac{d^2 u}{dz^2} = -\frac{G}{\mu}, \quad (5.251)$$

with solution

$$u(z) = \frac{G}{2\mu}(h^2 - z^2) + A(z+h) + B. \quad (5.252)$$

Application of the no-slip velocity matching constraint gives us in short order

$$u(z) = \frac{G}{2\mu}(h^2 - z^2) + v \left(1 - \frac{1}{2h}(z+h) \right). \quad (5.253)$$

With $v = 0$ this is the channel flow solution, and with $G = 0$ this is the shearing flow solution.

Having solved for the velocity at any height, we can also solve for the mass or volume flux through a slice of the channel. For the mass flux ρQ per unit time (given volume flux Q)

$$\int \frac{dm}{dt} = \int \rho \frac{dV}{dt} = \rho(\Delta A) \int \mathbf{u} \cdot \hat{\mathbf{t}}, \quad (5.254)$$

we find

$$\rho Q = \rho(\Delta y) \left(\frac{2Gh^3}{3\mu} + hv \right). \quad (5.255)$$

We can also calculate the force of the boundaries on the fluid. For example, the force per unit volume of the boundary at $z = \pm h$ on the fluid is found by calculating the tangential component of the traction vector taken with normal $\hat{\mathbf{n}} = \mp \hat{\mathbf{z}}$. That tangent vector is found to be

$$\boldsymbol{\sigma} \cdot (\pm \hat{\mathbf{n}}) = -p\hat{\mathbf{z}} \pm 2\mu \mathbf{e}_i e_{ij} \delta_{j3} = -p\hat{\mathbf{z}} \pm \hat{\mathbf{x}}\mu \frac{\partial u}{\partial z}. \quad (5.256)$$

The tangential component is the $\hat{\mathbf{x}}$ component evaluated at $z = \pm h$, so for the lower and upper interfaces we have

$$(\boldsymbol{\sigma} \cdot \hat{\mathbf{n}}) \cdot \hat{\mathbf{x}}|_{z=-h} = -G(-h) - \frac{v\mu}{2h} \quad (5.257)$$

$$(\boldsymbol{\sigma} \cdot -\hat{\mathbf{n}}) \cdot \hat{\mathbf{x}}|_{z=+h} = -G(+h) + \frac{v\mu}{2h}, \quad (5.258)$$

so the force per unit length that the lower interface boundary applies to the fluid is

$$L \left(Gh - \frac{v\mu}{2h} \right), \quad (5.259)$$

and the force per unit length that the upper interface boundary applies to the fluid is

$$L \left(-Gh + \frac{v\mu}{2h} \right). \quad (5.260)$$

Does the sign of the velocity term make sense? Let us consider the case where we have a zero pressure gradient and look at the lower interface. This is the force of the interface on the fluid, so the force of the fluid on the interface would have the opposite sign

$$\frac{v\mu}{2h}. \quad (5.261)$$

This does seem reasonable. Our fluid flowing along with a positive velocity is imparting a force on what it is flowing over in the same direction.

Exercise 5.9 Layered inclined viscous flow. (From §2 [2])

This is a slight variation on what we did in class.

Our problem is illustrated in fig. 5.30 with a plane set at angle α , fluid depths of $h^{(1)}$ and $h^{(2)}$ respectively, and viscosities $\mu^{(1)}$ and $\mu^{(2)}$.

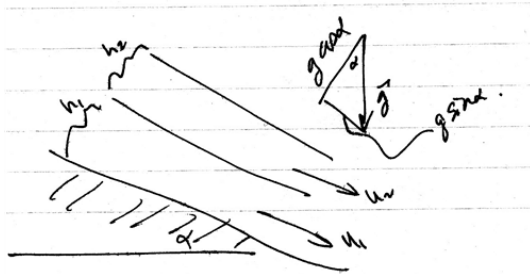

Figure 5.30: Two fluids layers in inclined flow.

Answer for Exercise 5.9

We have to setup of the equations of motion for this system. We will write $H = h^{(1)} + h^{(2)}$. We have a pair of Navier-Stokes equations to solve

$$\begin{aligned} \rho \frac{d\mathbf{u}^{(i)}}{dt} &= \rho \frac{\partial \mathbf{u}^{(i)}}{\partial t} + \rho(\mathbf{u}^{(i)} \cdot \nabla) \mathbf{u}^{(i)} \\ &= -\nabla p^{(i)} + \mu^{(i)} \nabla^2 \mathbf{u}^{(i)} + \mu^{(i)} \nabla(\nabla \cdot \mathbf{u}^{(i)}) + \rho \mathbf{g}. \end{aligned} \quad (5.262)$$

Our steady state and incompressibility constraints break this into a few independent equations

$$\begin{aligned}\rho \frac{\partial \mathbf{u}^{(i)}}{\partial t} &= 0 \\ \nabla \cdot \mathbf{u}^{(i)} &= 0 \\ \rho(\mathbf{u}^{(i)} \cdot \nabla) \mathbf{u}^{(i)} &= -\nabla p^{(i)} + \mu^{(i)} \nabla^2 \mathbf{u}^{(i)} + \rho \mathbf{g}.\end{aligned}\tag{5.263}$$

Let us require no components of the flows in the y , or z directions initially. As the equivalent of Newton's law for fluid flows, conservation of linear momentum requires that for our steady state problem we have $u_y = u_z = 0$ for the flows in both fluid layers.

Our problem is now reduced to a problem in four quantities (two velocities and two pressures). With $\mathbf{u}^{(i)} = (u^{(i)}, 0, 0)$ we can restate Navier-Stokes in coordinate form as

$$\partial_x u^{(i)}(x, y, z) = 0,\tag{5.264a}$$

$$\rho(u^{(i)} \partial_x u^{(i)} = -\partial_x p^{(i)} + \mu^{(i)}(\partial_{xx} + \partial_{yy} + \partial_{zz})u^{(i)} + \rho g \sin \alpha,\tag{5.264b}$$

$$0 = -\partial_y p^{(i)} - \rho g \cos \alpha,\tag{5.264c}$$

$$0 = -\partial_z p^{(i)}.\tag{5.264d}$$

In order to solve this, we have eight simultaneous non-linear PDEs, four unknown functions, plus boundary conditions!

What are the boundary conditions? One is the "no-slip" condition, the experimental observation that velocities match at the interfaces. So we should have zero velocity for the fluid lying against the plane, and velocity matching between the fluids. The air above the fluid will also be flowing along at the rate of the uppermost portion of the top layer, but we will neglect that effect (i.e. considering two layers of equal density and not three, with one having a separate density). We also have matching of the traction vectors at the interfaces.

Writing this, it occurred to me that I did not fully understand what motivated the traction vector matching boundary value condition. Talking to our Prof about this, the matching of the traction vectors at any point can be thought of as an observational issue, but this is also a force balance issue. There is an induced velocity in the direction of the traction vector at any given point. For example, when we have unidirectional flow, we must have no normal component of the traction vector, and only a tangential component, because we have only the tangential flow. It is probably reasonable to think about this roughly as the equivalent of matching both acceleration and velocity at the boundary, but because densities and viscosities vary, we have to match the traction vectors and not the acceleration itself.

Before continuing to solve our Navier-Stokes equations let us express the condition that the tangential component of the traction vectors match algebraically.

Dropping indices temporarily, for the normal to the surface $\hat{\mathbf{n}} = (n_1, n_2, n_3) = (0, 1, 0)$ we want to compute

$$\begin{aligned}
 \tau_1 &= \sigma_{1k}n_k \\
 &= \sigma_{1k}\delta_{2k} \\
 &= \sigma_{12} \\
 &= -p\delta_{12} + 2\mu e^{12} \\
 &= \mu \left(\frac{\partial u_1}{\partial y} + \frac{\partial u_2}{\partial x} \right).
 \end{aligned} \tag{5.265}$$

So the tangential component of the traction vector is

$$\mathbf{T}^{(i)} = \mu^{(i)} \frac{\partial u^{(i)}}{\partial y} \hat{\mathbf{x}}. \tag{5.266}$$

As noted above, this is in fact, the only component of the traction vector, since we do not have any non-horizontal flow.

Our boundary value conditions, what we need in addition to the Navier-Stokes equations of eq. (5.264), to solve our problem, are the matching at any interface of the following conditions

$$u^{(i)} = u^{(j)}, \tag{5.267a}$$

$$p^{(i)} = p^{(j)}, \tag{5.267b}$$

$$\mu^{(i)} \frac{\partial u^{(i)}}{\partial y} = \mu^{(i)} \frac{\partial u^{(j)}}{\partial y}. \quad (5.267c)$$

There are actually three interfaces to consider, that of the lower layer liquid with the inclined plane, the interface between the two fluid layers, and the interface between the upper layer fluid and the air above it.

Starting with the simplest, the z-coordinate equation, of Navier-Stokes eq. (5.264d), we can conclude that each of the pressures is not a function of z, so that we have

$$p^{(i)} = p^{(i)}(x, y). \quad (5.268)$$

Using this, we can integrate our y-coordinate Navier-Stokes equation eq. (5.264c), to find

$$p^{(i)} = -\rho g y \cos \alpha + f^{(i)}(x). \quad (5.269)$$

At this point we can introduce the first boundary value constraint, that the pressures must match at the interfaces. In particular, on the upper surface, where we have atmospheric pressure p_A our pressure is

$$p^{(2)}(H) = -\rho g H \cos \alpha + f^{(2)}(x) = p_A, \quad (5.270)$$

so $f^{(2)}$ is constant with value

$$f^{(2)}(x) = p_A + \rho g H \cos \alpha, \quad (5.271)$$

which fully determines the density of the upper surface

$$p^{(2)}(y) = \rho g \cos \alpha (H - y) + p_A. \quad (5.272)$$

Matching the pressure between the two layers of fluids we have

$$\begin{aligned} p^{(1)}(h_1) &= -\rho g h_1 \cos \alpha + f^{(1)}(x) \\ &= p^{(2)}(h_1) \\ &= \rho g \cos \alpha (H - h_1) + p_A, \end{aligned} \quad (5.273)$$

so that our undetermined function $f^{(1)}(x)$

$$f^{(1)}(x) = \rho g H \cos \alpha + p_A. \quad (5.274)$$

This is an intuitively satisfying result. With the densities equal, it seems sensible that the pressure would have a single functional form throughout both layers, dependent only on the total height y , independent of the velocities and viscosities. That is precisely what we find

$$p(y) = \rho g \cos \alpha (H - y) + p_A. \quad (5.275)$$

Having solved for the pressure, we are now set to return to the remaining Navier-Stokes equations eq. (5.264a), and eq. (5.264b) for this system. From eq. (5.264a) we see that the non-linear term on the LHS of eq. (5.264b) is killed and also see that our velocities can only be functions of y and z

$$u^{(i)} = u^{(i)}(y, z). \quad (5.276)$$

While more general solutions can likely be found, we will limit ourselves to looking only for solutions that are functions of y . From our solution to the pressure part of the problem $p^{(i)} = p^{(i)}(y)$, we also see that the pressure term $\partial_x p^{(i)}$ of eq. (5.264b) is killed. We are left with just

$$\begin{aligned} 0 &= \mu^{(i)}(\partial_{xx} + \partial_{yy} + \partial_{zz})u^{(i)} + \rho g \sin \alpha \\ &= \mu^{(i)}\partial_{yy}u^{(i)} + \rho g \sin \alpha \\ &= \mu^{(i)}\frac{d^2}{dy^2}u^{(i)} + \rho g \sin \alpha. \end{aligned} \quad (5.277)$$

This is directly integrable, and we find for the velocities and traction vectors respectively

$$u^{(i)} = -\frac{\rho g \sin \alpha}{2\mu^{(i)}}y^2 + A^{(i)}y + B^{(i)}, \quad (5.278a)$$

$$\tau_x^{(i)} = \mu^{(i)}\frac{\partial u^{(i)}}{\partial y} = -\rho g y \sin \alpha + \mu^{(i)}A^{(i)}. \quad (5.278b)$$

The boundary conditions left to exploit are

$$\begin{aligned} u^{(1)}(0) &= 0 \\ u^{(1)}(h_1) &= u^{(2)}(h_1) \\ \tau_x^{(1)}(h_1) &= \tau_x^{(2)}(h_1) \\ \tau_x^{(2)}(H) &= 0. \end{aligned} \quad (5.279)$$

The first is the no-slip condition with the plane. The last is an approximation that assumes the liquid is not producing a measurable force on the air above it. The other two are for the interfaces between the two fluids.

From $u^{(1)}(0) = 0$ we see immediately that we have $B^{(1)} = 0$. From the traction vector equality in the atmosphere, we have

$$0 = -\rho g H \sin \alpha + \mu^{(2)} A^{(2)}, \quad (5.280)$$

or

$$A^{(2)} = \frac{\rho g H \sin \alpha}{\mu^{(2)}}. \quad (5.281)$$

These reduce the problem to solving for two last integration constants, where our velocities are

$$\begin{aligned} u^{(1)} &= -\frac{\rho g \sin \alpha}{2\mu^{(1)}} y^2 + A^{(1)} y \\ u^{(2)} &= \frac{\rho g \sin \alpha}{2\mu^{(2)}} (2Hy - y^2) + B^{(2)}. \end{aligned} \quad (5.282)$$

and our traction vectors are

$$\begin{aligned} \tau_x^{(1)} &= -\rho g y \sin \alpha + \mu^{(1)} A^{(1)} \\ \tau_x^{(2)} &= \rho g \sin \alpha (H - y). \end{aligned} \quad (5.283)$$

Matching both at the interface ($y = h_1$) gives us

$$\begin{aligned} -\frac{\rho g \sin \alpha}{2\mu^{(1)}} h_1^2 + A^{(1)} h_1 &= \frac{\rho g \sin \alpha}{2\mu^{(2)}} h_1 (2h_2 + h_1) + B^{(2)} \\ -\rho g h_1 \sin \alpha + \mu^{(1)} A^{(1)} &= \rho g h_2 \sin \alpha. \end{aligned} \quad (5.284)$$

We find

$$A^{(1)} = \frac{\rho g H \sin \alpha}{\mu^{(1)}}, \quad (5.285)$$

and

$$\begin{aligned} B^{(2)} &= -\frac{\rho g \sin \alpha}{2\mu^{(1)}} h_1^2 + \frac{\rho g H \sin \alpha}{\mu^{(1)}} h_1 - \frac{\rho g \sin \alpha}{2\mu^{(2)}} h_1 (2h_2 + h_1) \\ &= \frac{\rho g h_1 \sin \alpha}{2} \left(-\frac{h_1}{\mu^{(1)}} + \frac{2H}{\mu^{(1)}} - \frac{2h_2 + h_1}{\mu^{(2)}} \right) \\ &= \frac{\rho g h_1 \sin \alpha}{2} (2h_2 + h_1) \left(\frac{1}{\mu^{(1)}} - \frac{1}{\mu^{(2)}} \right). \end{aligned} \quad (5.286)$$

So, finally, we have

$$\begin{aligned}
 u^{(1)}(y) &= \frac{\rho g \sin \alpha}{2\mu^{(1)}} (2Hy - y^2) \\
 u^{(2)}(y) &= \frac{\rho g \sin \alpha}{2\mu^{(2)}} \left(2Hy - y^2 + h_1(2h_2 + h_1) \left(\frac{\mu^{(2)}}{\mu^{(1)}} - 1 \right) \right) \quad (5.287) \\
 p(y) &= \rho g \cos \alpha (H - y) + p_A.
 \end{aligned}$$

The final result looks reasonable. If the viscosities are equal then we have the same velocity profile in both layers. That makes sense given the equal densities, since there would really be nothing that would then distinguish the two layers.

Exercise 5.10 Two layer inclined viscous flow.

Here is a generalization of one of the problems from §2 of [2], itself a slight variation on what we did in class.

In the previous calculation we did the calculation for two incompressible fluids of the same densities flowing down an inclined plane. Now, let us generalize this slightly, allowing for different densities.

I am curious how much the air in the neighborhood of some flowing water gets dragged by that flow. It never occurred to me that this would occur, and I had like to plug in some numbers and see what the results are. This should be something that can be modeled with two layers like this, one of fluid, one of air of a specific thickness (allowing pressure to vary due to the velocity gradient), and one final layer of air at a fixed pressure (atmospheric). I would not expect that problem to be much harder than this one, although it may end up being worthwhile to let a computer algebra system do some of the grunt work to solve all the resulting equations.

In the end, when we get to putting in some numbers for this problem, we can probably also get an idea how deep the region where the air gets dragged by the fluid can get.

Answer for Exercise 5.10

Our problem is illustrated in fig. 5.30 with a plane set at angle α , fluid depths of $h^{(1)}$ and $h^{(2)}$ respectively, and viscosities $\mu^{(1)}$ and

$\mu^{(2)}$. We will write $H = h^{(1)} + h^{(2)}$. We have a pair of Navier-Stokes equations to solve

$$\begin{aligned}\rho^{(i)} \frac{d\mathbf{u}^{(i)}}{dt} &= \rho^{(i)} \frac{\partial \mathbf{u}^{(i)}}{\partial t} + \rho^{(i)} (\mathbf{u}^{(i)} \cdot \nabla) \mathbf{u}^{(i)} \\ &= -\nabla p^{(i)} + \mu^{(i)} \nabla^2 \mathbf{u}^{(i)} + \mu^{(i)} \nabla (\nabla \cdot \mathbf{u}^{(i)}) + \rho^{(i)} \mathbf{g}.\end{aligned}\quad (5.288)$$

Our steady state and incompressibility constraints break this into a few independent equations

$$\begin{aligned}\rho^{(i)} \frac{\partial \mathbf{u}^{(i)}}{\partial t} &= 0 \\ \nabla \cdot \mathbf{u}^{(i)} &= 0 \\ \rho^{(i)} (\mathbf{u}^{(i)} \cdot \nabla) \mathbf{u}^{(i)} &= -\nabla p^{(i)} + \mu^{(i)} \nabla^2 \mathbf{u}^{(i)} + \rho^{(i)} \mathbf{g}.\end{aligned}\quad (5.289)$$

Let us require no components of the flows in the y , or z directions initially. As the equivalent of Newton's law for fluid flows, conservation of linear momentum requires that for our steady state problem we have $u_y = u_z = 0$ for the flows in both fluid layers. Our problem is now reduced to a problem in four quantities (two velocities and two pressures). With $\mathbf{u}^{(i)} = (u^{(i)}, 0, 0)$ we can restate Navier-Stokes in coordinate form as

$$\partial_x u^{(i)}(x, y, z) = 0, \quad (5.290a)$$

$$\rho^{(i)} (u^{(i)} \partial_x u^{(i)} = -\partial_x p^{(i)} + \mu^{(i)} (\partial_{xx} + \partial_{yy} + \partial_{zz}) u^{(i)} + \rho^{(i)} g \sin \alpha, \quad (5.290b)$$

$$0 = -\partial_y p^{(i)} - \rho^{(i)} g \cos \alpha, \quad (5.290c)$$

$$0 = -\partial_z p^{(i)}. \quad (5.290d)$$

In order to solve this, we have eight simultaneous non-linear PDEs, four unknown functions, plus boundary conditions!

What are the boundary conditions? One is the "no-slip" condition, the experimental observation that velocities match at the interfaces. So we should have zero velocity for the fluid lying

against the plane, and velocity matching between the fluids. The air above the fluid will also be flowing along at the rate of the uppermost portion of the top layer, but we will neglect that effect (i.e. considering two layers of equal density and not three, with one having a separate density). We also have matching of the traction vectors at the interfaces.

Writing this, it occurred to me that I did not fully understand what motivated the traction vector matching boundary value condition. Talking to our Prof about this, the matching of the traction vectors at any point can be thought of as an observational issue, but this is also a force balance issue. There is an induced velocity in the direction of the traction vector at any given point. For example, when we have unidirectional flow, we must have no normal component of the traction vector, and only a tangential component, because we have only the tangential flow. It is probably reasonable to think about this roughly as the equivalent of matching both acceleration and velocity at the boundary, but because densities and viscosities vary, we have to match the traction vectors and not the acceleration itself.

Before continuing to solve our Navier-Stokes equations let us express the condition that the tangential component of the traction vectors match algebraically. Dropping indices temporarily, for the normal to the surface $\hat{\mathbf{n}} = (n_1, n_2, n_3) = (0, 1, 0)$ we want to compute

$$\begin{aligned}
 \tau_1 &= \sigma_{1k} n_k \\
 &= \sigma_{1k} \delta_{2k} \\
 &= \sigma_{12} \\
 &= -p\delta_{12} + 2\mu e^{12} \\
 &= \mu \left(\frac{\partial u_1}{\partial y} + \frac{\partial u_2}{\partial x} \right).
 \end{aligned} \tag{5.291}$$

So the tangential component of the traction vector is

$$\boldsymbol{\tau}^{(i)} = \mu^{(i)} \frac{\partial u^{(i)}}{\partial y} \hat{\mathbf{x}}. \tag{5.292}$$

As noted above, this is in fact, the only component of the traction vector, since we do not have any non-horizontal flow. Our boundary value conditions, what we need in addition to the Navier-Stokes

equations of eq. (5.290), to solve our problem, are the matching at any interface of the following conditions

$$u^{(i)} = u^{(j)}, \quad (5.293a)$$

$$p^{(i)} = p^{(j)}, \quad (5.293b)$$

$$\mu^{(i)} \frac{\partial u^{(i)}}{\partial y} = \mu^{(j)} \frac{\partial u^{(j)}}{\partial y}. \quad (5.293c)$$

There are actually three interfaces to consider, that of the lower layer liquid with the inclined plane, the interface between the two fluid layers, and the interface between the upper layer fluid and the air above it. Starting with the simplest, the z -coordinate equation, of Navier-Stokes eq. (5.290d), we can conclude that each of the pressures is not a function of z , so that we have

$$p^{(i)} = p^{(i)}(x, y). \quad (5.294)$$

Using this, we can integrate our y -coordinate Navier-Stokes equation eq. (5.290c), to find

$$p^{(i)} = -\rho^{(i)} g y \cos \alpha + f^{(i)}(x). \quad (5.295)$$

At this point we can introduce the first boundary value constraint, that the pressures must match at the interfaces. In particular, on the upper surface, where we have atmospheric pressure p_A our pressure is

$$p^{(2)}(H) = -\rho^{(2)} g H \cos \alpha + f^{(2)}(x) = p_A, \quad (5.296)$$

so $f^{(2)}$ is constant with value

$$f^{(2)}(x) = p_A + \rho^{(2)} g H \cos \alpha, \quad (5.297)$$

which fully determines the density of the upper surface

$$p^{(2)}(y) = \rho^{(2)} g \cos \alpha (H - y) + p_A. \quad (5.298)$$

Matching the pressure between the two layers of fluids we have

$$\begin{aligned}
 p^{(1)}(h_1) &= -\rho^{(1)}gh_1 \cos \alpha + f^{(1)}(x) \\
 &= p^{(2)}(h_1) \\
 &= \rho^{(2)}g \cos \alpha(H - h_1) + p_A \\
 &= \rho^{(2)}gh_2 \cos \alpha + p_A,
 \end{aligned} \tag{5.299}$$

so that our undetermined function $f^{(1)}(x)$ is

$$f^{(1)}(x) = \left(\rho^{(1)}h_1 + \rho^{(2)}h_2 \right) g \cos \alpha + p_A. \tag{5.300}$$

With the densities not equal, we no longer find that the pressure is dependent only on the total height y , independent of the velocities and viscosities

$$p^{(1)}(y) = g \cos \alpha \left(\rho^{(1)}(h_1 - y) + \rho^{(2)}h_2 \right) + p_A. \tag{5.301}$$

However, this is still a fairly satisfying result. The pressure on the bottom layer is the total pressure due to the layer above it (the contribution due to the total height h_2 of that layer of the fluid). To that we add the pressure at our specific height, a linear function of the difference from the interface above it. Specified piecewise our pressure is now fully determined

$$p(y) = \begin{cases} g \cos \alpha \left(\rho^{(1)}(h_1 - y) + \rho^{(2)}h_2 \right) + p_A & y < h_1 \\ \rho^{(2)}g \cos \alpha(H - y) + p_A & y \in [h_1, h_1 + h_2] \\ p_A & y > H. \end{cases}$$

(5.302)

Observe that we have the usual ρgh form in all the terms of the pressure above, just scaled by the cosine of the angle since only a portion of the gravitational force is pushing normally on the fluids.

Having solved for the pressure, we are now set to return to the remaining Navier-Stokes equations eq. (5.290a), and eq. (5.290b) for this system. From eq. (5.290a) we see that the non-linear term

on the LHS of eq. (5.290b) is killed and also see that our velocities can only be functions of y and z

$$u^{(i)} = u^{(i)}(y, z). \quad (5.303)$$

While more general solutions can likely be found, we will limit ourselves to looking only for solutions that are functions of y . From our solution to the pressure part of the problem $p^{(i)} = p^{(i)}(y)$, we also see that the pressure term $\partial_x p^{(i)}$ of eq. (5.290b) is killed. We are left with just

$$\begin{aligned} 0 &= \mu^{(i)}(\partial_{xx} + \partial_{yy} + \partial_{zz})u^{(i)} + \rho^{(i)}g \sin \alpha \\ &= \mu^{(i)}\partial_{yy}u^{(i)} + \rho^{(i)}g \sin \alpha \\ &= \mu^{(i)}\frac{d^2}{dy^2}u^{(i)} + \rho^{(i)}g \sin \alpha. \end{aligned} \quad (5.304)$$

This is directly integrable, and we find for the velocities and traction vectors respectively

$$u^{(i)} = -\frac{\rho^{(i)}g \sin \alpha}{2\mu^{(i)}}y^2 + A^{(i)}y + B^{(i)}, \quad (5.305a)$$

$$\tau_x^{(i)} = \mu^{(i)}\frac{\partial u^{(i)}}{\partial y} = -\rho^{(i)}gy \sin \alpha + \mu^{(i)}A^{(i)}. \quad (5.305b)$$

The boundary conditions left to exploit are

$$\begin{aligned} u^{(1)}(0) &= 0 \\ u^{(1)}(h_1) &= u^{(2)}(h_1) \\ \tau_x^{(1)}(h_1) &= \tau_x^{(2)}(h_1) \\ \tau_x^{(2)}(H) &= 0. \end{aligned} \quad (5.306)$$

The first is the no-slip condition with the plane. The last is an approximation that assumes the liquid is not producing a measurable force on the air above it. The other two are for the interfaces between the two fluids.

From $u^{(1)}(0) = 0$ we see immediately that we have $B^{(1)} = 0$. From the traction vector equality in the atmosphere, we have

$$0 = -\rho^{(2)}gH \sin \alpha + \mu^{(2)}A^{(2)}, \quad (5.307)$$

or

$$A^{(2)} = \frac{\rho^{(2)} g H \sin \alpha}{\mu^{(2)}}. \quad (5.308)$$

These reduce the problem to solving for two last integration constants, where our velocities are

$$\begin{aligned} u^{(1)} &= -\frac{\rho^{(1)} g \sin \alpha}{2\mu^{(1)}} y^2 + A^{(1)} y \\ u^{(2)} &= \frac{\rho^{(2)} g \sin \alpha}{2\mu^{(2)}} (2Hy - y^2) + B^{(2)}. \end{aligned} \quad (5.309)$$

and our traction vectors are

$$\begin{aligned} \tau_x^{(1)} &= -\rho^{(1)} g y \sin \alpha + \mu^{(1)} A^{(1)} \\ \tau_x^{(2)} &= \rho^{(2)} g \sin \alpha (H - y). \end{aligned} \quad (5.310)$$

Matching both at the interface ($y = h_1$) gives us

$$\begin{aligned} -\frac{\rho^{(1)} g \sin \alpha}{2\mu^{(1)}} h_1^2 + A^{(1)} h_1 &= \frac{\rho^{(2)} g \sin \alpha}{2\mu^{(2)}} h_1 (2h_2 + h_1) + B^{(2)} \\ -\rho^{(1)} g h_1 \sin \alpha + \mu^{(1)} A^{(1)} &= \rho^{(2)} g h_2 \sin \alpha. \end{aligned} \quad (5.311)$$

We find

$$A^{(1)} = \frac{1}{\mu^{(1)}} (\rho^{(1)} h_1 + \rho^{(2)} h_2) g \sin \alpha. \quad (5.312)$$

Let us substitute this back for our first fluid velocity

$$\begin{aligned} u^{(1)} &= -\frac{\rho^{(1)} g \sin \alpha}{2\mu^{(1)}} y^2 + \frac{y}{\mu^{(1)}} (\rho^{(1)} h_1 + \rho^{(2)} h_2) g \sin \alpha \\ &= g \sin \alpha \left(-\frac{\rho^{(1)}}{2\mu^{(1)}} y^2 + \frac{y}{\mu^{(1)}} (\rho^{(1)} h_1 + \rho^{(2)} h_2) \right) \\ &= \frac{g y \sin \alpha}{2\mu^{(1)}} \left(\rho^{(1)} (2h_1 - y) + 2\rho^{(2)} h_2 \right). \end{aligned} \quad (5.313)$$

As a check we see this is consistent with the previous calculation when $\rho^{(1)} = \rho^{(2)}$. For our final integration constant we now find

$$\begin{aligned} B^{(2)} &= \frac{g h_1 \sin \alpha}{2\mu^{(1)}} \left(\rho^{(1)} h_1 + 2\rho^{(2)} h_2 \right) - \frac{\rho^{(2)} g \sin \alpha}{2\mu^{(2)}} h_1 (2h_2 + h_1) \\ &= \frac{g h_1 \sin \alpha}{2} \left(\frac{1}{\mu^{(1)}} \left(\rho^{(1)} h_1 + 2\rho^{(2)} h_2 \right) - \frac{\rho^{(2)}}{\mu^{(2)}} (2h_2 + h_1) \right) \\ &= \frac{g h_1 \sin \alpha}{2\mu^{(2)}} \left(\frac{\mu^{(2)}}{\mu^{(1)}} \left(\rho^{(1)} h_1 + 2\rho^{(2)} h_2 \right) - \rho^{(2)} (2h_2 + h_1) \right). \end{aligned} \quad (5.314)$$

So, finally, we have for the velocities

$$u^{(1)}(y) = \frac{gy \sin \alpha}{2\mu^{(1)}} \left(\rho^{(1)}(2h_1 - y) + 2\rho^{(2)}h_2 \right), \quad (5.315a)$$

$$u^{(2)}(y) = \frac{g \sin \alpha}{2\mu^{(2)}} \left(\rho^{(2)} (2Hy - y^2) + h_1 \left(\frac{\mu^{(2)}}{\mu^{(1)}} \left(\rho^{(1)}h_1 + 2\rho^{(2)}h_2 \right) - \rho^{(2)} (2h_2 + h_1) \right) \right). \quad (5.315b)$$

The final result looks reasonable. If the viscosities and densities are equal then we have the same velocity profile in both layers. That makes sense given the equal densities, since there would really be nothing that would then distinguish the two layers.

To try this out numerically see ([twoLayerInclinedFlowDifferent-Densities.cdf](#)).

The results are fairly surprising. Specifically, insertion of an air layer above the water ends up with the air speed humongous! Steady state not realistic? What are the length scales required for steady state? Are these so large that we would have to vary the gravitational field?

I think that this shows either an error in this calculation, an error programming the worksheet, or the folly of even considering a steady state flow of this form for anything that is not extremely viscous.

Some further validation is required to see what is up. One part of that validation is now done. To rule out algebraic errors above see the verification in ([twoLayerInclinedFlowDifferentDensitiesThe-Calculation.cdf](#)). Using Solve to find $A^{(i)}$, and $B^{(i)}$ I get exactly the same answers as with my hand calculations above. I also verified that substituting back in the boundary value conditions yields the expected equalities.

Exercise 5.11 Channel flow, step pressure. ([2] problem 2.5)

Viscous fluid is at rest in a two-dimensional channel between stationary rigid walls with $y = \pm h$. For $t \geq 0$ a constant pressure gradient $P = -dp/dx$ is imposed. Show that $u(y, t)$ satisfies

$$\frac{\partial u}{\partial t} = \nu \frac{\partial^2 u}{\partial y^2} + \frac{P}{\rho}, \quad (5.316)$$

and give suitable initial and boundary conditions. Find $u(y, t)$ in form of a Fourier series, and show that the flow approximates to steady channel flow when $t \gg h^2/\nu$.

Answer for Exercise 5.11

With only horizontal components to the flow, the Navier-Stokes equations for incompressible flow are

$$\frac{\partial u}{\partial t} + u \frac{\partial u}{\partial x} = -\frac{1}{\rho} \frac{\partial p}{\partial x} + \nu \left(\frac{\partial^2}{\partial x^2} + \frac{\partial^2}{\partial y^2} \right) u, \quad (5.317a)$$

$$\frac{\partial u}{\partial x} = 0. \quad (5.317b)$$

Substitution of eq. (5.317b) into eq. (5.317a) gives us

$$\frac{\partial u}{\partial t} = -\frac{1}{\rho} \frac{\partial p}{\partial x} + \nu \frac{\partial^2 u}{\partial y^2}. \quad (5.318)$$

Our equation to solve is therefore

$$\boxed{\frac{\partial u}{\partial t} = \Theta(t) \frac{P}{\rho} + \nu \frac{\partial^2 u}{\partial y^2}.} \quad (5.319)$$

This equation, for $t < 0$, allows for solutions

$$u = Ay + B, \quad (5.320)$$

but the problem states that the fluid is at rest initially, so we do not really have to solve anything (i.e. $A = B = 0$).

The no-slip conditions introduce boundary value conditions $u(\pm h, t) = 0$. For $t \geq 0$ we have

$$\frac{\partial u}{\partial t} = \frac{P}{\rho} + \nu \frac{\partial^2 u}{\partial y^2}. \quad (5.321)$$

If we attempt separation of variables with $u(y, t) = Y(y)T(t)$, our equation takes the form

$$T'Y = \frac{P}{\rho} + \nu TY'' . \quad (5.322)$$

We see that the non-homogeneous term prevents successful application of separation of variables. Let us modify our problem by attempting to recast our equation into a homogeneous form by adding a particular solution for the steady state flow problem. That problem was the solution of

$$\frac{\partial^2}{\partial y^2} u_s(y, 0) = -\frac{P}{\rho\nu} , \quad (5.323)$$

which has solution

$$u_s(y, 0) = \frac{P}{2\rho\nu} (h^2 - y^2) + Ay + B . \quad (5.324)$$

The freedom to incorporate an h^2 constant into the equation as an integration constant has been employed, knowing that it will kill the y^2 contributions at $y = \pm h$ to make the boundary condition matching easier. Our no-slip conditions give us

$$\begin{aligned} 0 &= Ah + B \\ 0 &= -Ah + B . \end{aligned} \quad (5.325)$$

Adding this we have $2B = 0$, and subtracting gives us $2Ah = 0$, so a specific solution that matches our required boundary value (and initial value) conditions is just the steady state channel flow solution we are familiar with

$$u_s(y, 0) = \frac{P}{2\rho\nu} (h^2 - y^2) . \quad (5.326)$$

Let us now assume that our general solution has the form

$$u(y, t) = u_H(y, t) + u_s(y, 0) . \quad (5.327)$$

Applying the Navier-Stokes equation to this gives us

$$\frac{\partial u_H}{\partial t} = \frac{P}{\rho} + \nu \frac{\partial^2 u_H}{\partial y^2} + \nu \frac{\partial^2 u_s}{\partial y^2} . \quad (5.328)$$

But from eq. (5.323), we see that all we have left is a homogeneous problem in u_H

$$\frac{\partial u_H}{\partial t} = \nu \frac{\partial^2 u_H}{\partial y^2}, \quad (5.329)$$

where our boundary value conditions are now given by

$$\begin{aligned} 0 &= u_H(\pm h, t) + u_s(\pm h) \\ &= u_H(\pm h, t), \end{aligned} \quad (5.330)$$

and

$$\begin{aligned} 0 &= u(y, 0) \\ &= u_H(y, 0) + \frac{P}{2\rho\nu} (h^2 - y^2), \end{aligned} \quad (5.331)$$

or

$$u_H(\pm h, t) = 0, \quad (5.332a)$$

$$u_H(y, 0) = -\frac{P}{2\rho\nu} (h^2 - y^2). \quad (5.332b)$$

Now we can apply separation of variables with $u_H = T(t)Y(y)$, yielding

$$T'Y = \nu TY'', \quad (5.333)$$

or

$$\frac{T'}{T} = \nu \frac{Y''}{Y} = \text{constant} = -\nu\alpha^2. \quad (5.334)$$

Here a positive constant $\nu\alpha^2$ has been used assuming that we want a solution that is damped with time. Our solutions are

$$\begin{aligned} T &\propto e^{-\nu\alpha^2 t} \\ Y &= A \sin \alpha y + B \cos \alpha y, \end{aligned} \quad (5.335)$$

or

$$u_H(y, t) = \sum_{\alpha} e^{-\alpha^2 \nu t} (A_{\alpha} \sin \alpha y + B_{\alpha} \cos \alpha y). \quad (5.336)$$

We have constraints on α due to our boundary value conditions. For our sin terms to be solutions we require

$$\sin(\alpha(\pm h)) = \sin n\pi, \quad (5.337)$$

and for our cosine terms to be solutions we require

$$\cos(\alpha(\pm h)) = \cos\left(\frac{\pi}{2} + n\pi\right), \quad (5.338)$$

$$\begin{aligned} \alpha &= \frac{2n\pi}{2h} \\ \alpha &= \frac{2n + 1\pi}{2h}, \end{aligned} \quad (5.339)$$

respectively. Our homogeneous solution therefore takes the form

$$u_H(y, t) = C_0 + \sum_{m>0} C_m e^{-(m\pi/2h)^2 vt} \begin{cases} \sin\left(\frac{m\pi y}{2h}\right) & m \text{ even} \\ \cos\left(\frac{m\pi y}{2h}\right) & m \text{ odd.} \end{cases} \quad (5.340)$$

Our undetermined constants should be provided by the boundary value constraint at $t = 0$ eq. (5.332b), leaving us to solve the Fourier problem

$$-\frac{P}{2\mu} (h^2 - y^2) = \sum_{m \geq 0} C_m \begin{cases} \sin\left(\frac{m\pi y}{2h}\right) & m \text{ even} \\ \cos\left(\frac{m\pi y}{2h}\right) & m \text{ odd.} \end{cases} \quad (5.341)$$

Multiplying by a sine and integrating will clearly give zero (even times odd function over a symmetric interval). Let us see if there is any scaling required to select out the C_m term

$$\begin{aligned} &\int_{-h}^h \cos\left(\frac{m\pi y}{2h}\right) \cos\left(\frac{n\pi y}{2h}\right) dy \\ &= \frac{2h}{\pi} \int_{-h}^h \cos\left(\frac{m\pi y}{2h}\right) \cos\left(\frac{n\pi y}{2h}\right) \pi dy / 2h \\ &= \frac{2h}{\pi} \int_{-\pi/2}^{\pi/2} \cos mx \cos nx dx \\ &= \frac{h}{\pi} \int_{-\pi/2}^{\pi/2} (\cos((m-n)\pi/2) + \cos((m+n)\pi/2)) dx. \end{aligned} \quad (5.342)$$

Note that since m and n must be odd, $m \pm n = 2c$ for some integer c , so this integral is zero unless $m = n$ (consider $m = 2a + 1, n = 2b + 1$). For the $m = n$ term we have

$$\int_{-h}^h \cos\left(\frac{m\pi y}{2h}\right) \cos\left(\frac{n\pi y}{2h}\right) dy = \frac{h}{\pi} \int_{-\pi/2}^{\pi/2} (1 + \cos(m\pi)) dx \quad (5.343)$$

$$= h.$$

Therefore, our constants C_m (for odd m) are given by

$$C_m = -\frac{Ph}{2\mu} \int_{-h}^h \left(1 - \left(\frac{y}{h}\right)^2\right) \cos\left(\frac{m\pi y}{2h}\right) dy \quad (5.344)$$

$$= -\frac{Ph^2}{2\mu} \int_{-1}^1 (1 - x^2) \cos\left(\frac{m\pi x}{2}\right) x.$$

With $m = 2n + 1$, we have

$$C_{2n+1} = -\frac{16Ph^2(-1)^n}{\mu\pi^3(2n+1)^3}. \quad (5.345)$$

For that calculation see ([channelFlowWithStepPressureGradient.cdf](#)). Our complete solution is

$$u(y, t) = \frac{Ph^2}{2\mu} \left(1 - \left(\frac{y}{h}\right)^2\right) - \frac{16Ph^2}{\mu\pi^3} \sum_{n=0}^{\infty} \frac{(-1)^n}{(2n+1)^3} e^{-((2n+1)\pi/2h)^2 vt} \cos\left(\frac{(2n+1)\pi y}{2h}\right). \quad (5.346)$$

The largest of the damped exponentials above is the $n = 0$ term which is

$$e^{-\pi^2 vt/h^2}, \quad (5.347)$$

so if $vt \gg h^2$ these terms all die off, leaving us with just the steady state.

Rather remarkably, this Fourier series is actually a very good fit even after only a single term. Using the viscosity and density of water, $h = 1\text{cm}$, and $P = 3 \times \mu_{\text{water}} \times (2\text{cm/s})/h^2$ (parameterizing the pressure gradient by the average velocity it will induce), a plot of the parabola that we are fitting to and the difference of that

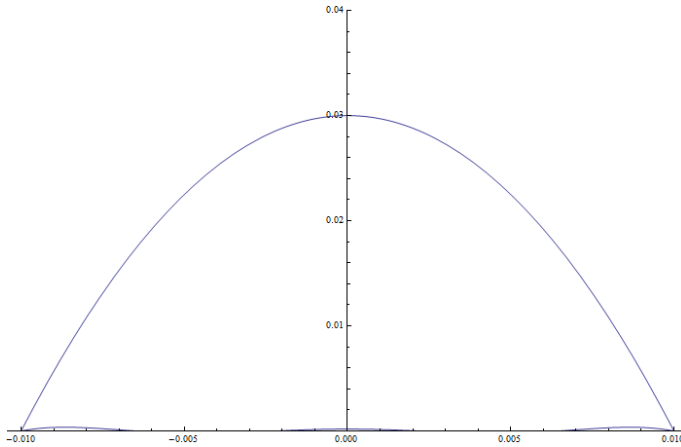

Figure 5.31: Parabolic channel flow steady state, and difference from first Fourier term.

from the first Fourier term is shown in fig. 5.31. The higher order corrections are even smaller. Even the first order deviations from the parabola that we are fitting to is a correction on the scale of $1/100$ of the height of the parabola. This is illustrated in fig. 5.32 where the magnitude of the first 5 deviations from the steady state are plotted. An animation of the time evolution above can be found

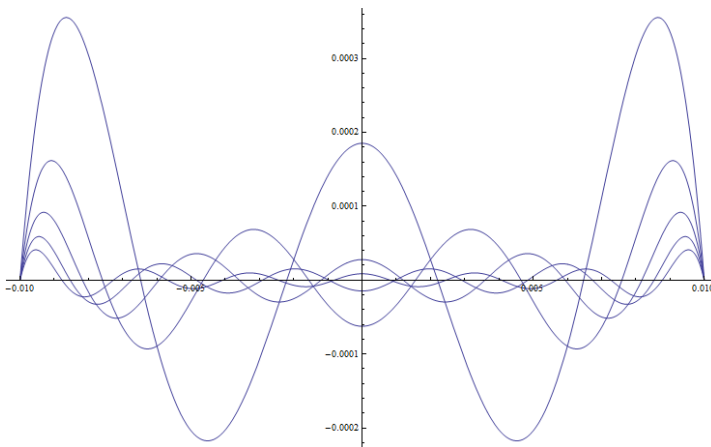

Figure 5.32: Difference from the steady state for the first five Fourier terms.

at <http://youtu.be/ovZuv9HBtmo>.

It is also interesting to look at the very earliest part of the time evolution (<http://youtu.be/dDkx8iLwOew>), where some oscillatory phenomena can be seen. Could some of that be due to not running with enough Fourier terms in this early part of the evolution when more terms are probably significant?

Exercise 5.12 *Couette flow. (2011 phy1530 ps2)*

Consider incompressible viscous steady flow between two long cylinders of radii R_1 and R_2 , $R_2 > R_1$, rotating about their axes with angular velocities Ω_1 , Ω_2 . Look for a solution of the form, where $\hat{\phi}$ is a unit vector along the azimuthal direction:

$$\mathbf{u} = v(r)\hat{\phi}, \quad (5.348a)$$

$$p = p(r). \quad (5.348b)$$

- a. Write out the Navier-Stokes equations and find differential equations for $v(r)$ and $p(r)$. You should find that these equations have relatively simple solutions, i.e.,

$$v(r) = ar + \frac{b}{r}. \quad (5.349)$$

- b. Fix the constants a and b from the boundary conditions. Determine the pressure $p(r)$.
- c. Compute the friction forces that the fluid exerts on the cylinders, and compute the torque on each cylinder. Show that the total torque on the fluid is zero (as must be the case).

Answer for Exercise 5.12

This is also a problem that I recall was outlined in §2 from [2]. Some of the instabilities that are mentioned in the text are nicely illustrated in [32].

We illustrate our system in fig. 5.33.

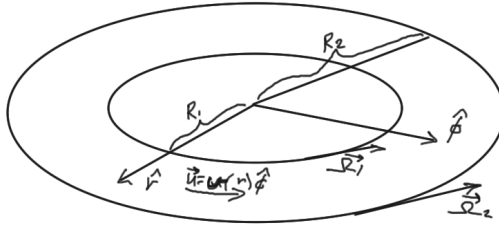

Figure 5.33: Couette flow configuration.

Solution Part a. Navier-Stokes. Navier-Stokes for steady state incompressible flow has the form

$$(\mathbf{u} \cdot \nabla)\mathbf{u} = -\frac{1}{\rho}\nabla p + \nu\nabla^2\mathbf{u}, \quad (5.350a)$$

$$\nabla \cdot \mathbf{u} = 0. \quad (5.350b)$$

where the gradient has the form

$$\nabla = \hat{\mathbf{r}}\partial_r + \frac{\hat{\boldsymbol{\phi}}}{r}\partial_\phi. \quad (5.351)$$

Let us first verify that the incompressible condition eq. (5.350b) is satisfied for the presumed form of the solution we seek. We have

$$\begin{aligned} \nabla \cdot \mathbf{u} &= \left(\hat{\mathbf{r}}\partial_r + \frac{\hat{\boldsymbol{\phi}}}{r}\partial_\phi \right) \cdot (v(r)\hat{\boldsymbol{\phi}}(\phi)) \\ &= (\hat{\mathbf{r}} \cdot \hat{\boldsymbol{\phi}})v' + \frac{\hat{\boldsymbol{\phi}}^2}{r}\partial_\phi v(r) + \frac{v(r)\hat{\boldsymbol{\phi}}}{r} \cdot \partial_\phi \hat{\boldsymbol{\phi}} \\ &= \frac{v(r)\hat{\boldsymbol{\phi}}}{r} \cdot (-\hat{\mathbf{r}}) \\ &= 0. \end{aligned} \quad (5.352)$$

Good. Now let us write out the terms of the momentum conservation equation eq. (5.350a). We have got

$$\begin{aligned} (\mathbf{u} \cdot \nabla)\mathbf{u} &= \frac{v}{r}\partial_\phi(v\hat{\boldsymbol{\phi}}) \\ &= -\frac{v^2\hat{\mathbf{r}}}{r}, \end{aligned} \quad (5.353)$$

and

$$\begin{aligned} -\frac{1}{\rho} \nabla p &= -\frac{1}{\rho} \left(\hat{\mathbf{r}} \partial_r + \frac{\hat{\boldsymbol{\phi}}}{r} \partial_\phi \right) p(r) \\ &= -\frac{\hat{\mathbf{r}} p'}{\rho}, \end{aligned} \quad (5.354)$$

and

$$\begin{aligned} \nu \nabla^2 \mathbf{u} &= \nu \left(\hat{\mathbf{r}} \partial_r + \frac{\hat{\boldsymbol{\phi}}}{r} \partial_\phi \right) \cdot \left(\hat{\mathbf{r}} \partial_r + \frac{\hat{\boldsymbol{\phi}}}{r} \partial_\phi \right) (v(r) \hat{\boldsymbol{\phi}}(\phi)) \\ &= \nu \left(\partial_{rr} + \frac{1}{r^2} \partial_{\phi\phi} + \frac{\hat{\boldsymbol{\phi}}}{r} \partial_\phi \cdot (\hat{\mathbf{r}} \partial_r) \right) (v(r) \hat{\boldsymbol{\phi}}(\phi)) \\ &= \nu \left(\partial_{rr} + \frac{1}{r^2} \partial_{\phi\phi} + \frac{1}{r} \partial_r \right) (v(r) \hat{\boldsymbol{\phi}}(\phi)) \\ &= \nu \left(\frac{1}{r} \partial_r (r \partial_r) + \frac{1}{r^2} \partial_{\phi\phi} \right) (v(r) \hat{\boldsymbol{\phi}}(\phi)) \\ &= \nu \left(\frac{1}{r} (rv')' - \frac{v}{r^2} \right) \hat{\boldsymbol{\phi}}. \end{aligned} \quad (5.355)$$

So the momentum equation of Navier-Stokes takes the form

$$\boxed{-\frac{v^2 \hat{\mathbf{r}}}{r} = -\frac{\hat{\mathbf{r}} p'}{\rho} + \nu \left(\frac{1}{r} (rv')' - \frac{v}{r^2} \right) \hat{\boldsymbol{\phi}}.} \quad (5.356)$$

Equating $\hat{\mathbf{r}}$ and $\hat{\boldsymbol{\phi}}$ components we have two equations to solve

$$r(rv')' - v = 0, \quad (5.357a)$$

$$p' = \frac{\rho v^2}{r}. \quad (5.357b)$$

Expanding out our velocity equation we have

$$r^2 v'' + rv' - v = 0, \quad (5.358)$$

for which we have been told to expect that eq. (5.349) is a solution (and it has the two integration constants we require for a solution to a homogeneous equation of this form). Let us verify that we

have computed the correct differential equation for the problem by trying this solution

$$\begin{aligned}
 r^2 v'' + r v' - v &= r^2 \left(a - \frac{b}{r^2} \right)' + r \left(a - \frac{b}{r^2} \right) - ar - \frac{b}{r} \\
 &= r^2 \frac{2b}{r^3} + \cancel{ar} - \frac{b}{r} - \cancel{ar} - \frac{b}{r} \\
 &= \frac{2b}{r} - \frac{2b}{r} \\
 &= 0.
 \end{aligned} \tag{5.359}$$

Given the velocity, we can now determine the pressure up to a constant

$$\begin{aligned}
 p' &= \frac{\rho}{r} \left(ar + \frac{b}{r} \right)^2 \\
 &= \frac{\rho}{r} \left(a^2 r^2 + \frac{b^2}{r^2} + 2ab \right) \\
 &= \rho \left(a^2 r + \frac{b^2}{r^3} + 2 \frac{ab}{r} \right),
 \end{aligned} \tag{5.360}$$

so

$$p_r - p_0 = \rho \left(\frac{1}{2} a^2 r^2 - \frac{b^2}{2r^2} + 2ab \ln r \right). \tag{5.361}$$

Solution Part b. Constants and the pressure. To determine our integration constants we recall that velocity associated with a radial position $\mathbf{x} = r\hat{\mathbf{r}}$ in cylindrical coordinates takes the form

$$\frac{\mathbf{x}}{dt} = \dot{r}\hat{\mathbf{r}} + r\dot{\phi}\hat{\phi}, \tag{5.362}$$

where $\dot{\phi}$ is the angular velocity. The cylinder walls therefore have the velocity

$$v = r\dot{\phi}, \tag{5.363}$$

so our boundary conditions (given a no-slip assumption for the fluids) are

$$\begin{aligned}
 v(R_1) &= R_1 \Omega_1 \\
 v(R_2) &= R_2 \Omega_2.
 \end{aligned} \tag{5.364}$$

This gives us a pair of equations to solve for a and b

$$\begin{aligned} R_1\Omega_1 &= aR_1 + \frac{b}{R_1} \\ R_2\Omega_2 &= aR_2 + \frac{b}{R_2}. \end{aligned} \tag{5.365}$$

Multiplying each by R_1 and R_2 respectively gives us

$$b = R_1^2(\Omega_1 - a) = R_2^2(\Omega_2 - a). \tag{5.366}$$

Rearranging for a we find

$$R_1^2\Omega_1 - R_2^2\Omega_2 = (R_1^2 - R_2^2)a, \tag{5.367}$$

or

$$a = \frac{R_2^2\Omega_2 - R_1^2\Omega_1}{R_2^2 - R_1^2}. \tag{5.368}$$

For b we have

$$\begin{aligned} b &= R_1^2(\Omega_1 - a) \\ &= \frac{R_1^2}{R_2^2 - R_1^2} (\Omega_1(R_2^2 - R_1^2) - R_2^2\Omega_2 + R_1^2\Omega_1), \end{aligned} \tag{5.369}$$

or

$$b = \frac{R_1^2R_2^2}{R_2^2 - R_1^2} (\Omega_1 - \Omega_2). \tag{5.370}$$

This gives us

$$v(r) = \frac{1}{R_2^2 - R_1^2} \left((R_2^2\Omega_2 - R_1^2\Omega_1) r + \frac{R_1^2R_2^2}{r} (\Omega_1 - \Omega_2) \right), \tag{5.371a}$$

$$\begin{aligned} p(r) - p_0 &= \frac{\rho}{(R_2^2 - R_1^2)^2} \times \left(\frac{1}{2} (R_2^2\Omega_2 - R_1^2\Omega_1)^2 r^2 - \frac{R_1^4R_2^4}{2r^2} (\Omega_1 - \Omega_2)^2 \right. \\ &\quad \left. + 2 (R_2^2\Omega_2 - R_1^2\Omega_1) R_1^2R_2^2 (\Omega_1 - \Omega_2) \ln r \right). \end{aligned} \tag{5.371b}$$

Solution Part c. *Friction torque on the cylinders.* We can expand out the identity for the traction vector

$$\begin{aligned} \mathbf{t}_{\hat{\mathbf{n}}} &= \mathbf{e}_i \sigma_{ij} n_j \\ &= -p \hat{\mathbf{n}} + \mu (2(\hat{\mathbf{n}} \cdot \nabla) \mathbf{u} + \hat{\mathbf{n}} \times (\nabla \times \mathbf{u})), \end{aligned} \quad (5.372)$$

in cylindrical coordinates and find

$$\mathbf{t}_{\hat{\mathbf{r}}} \cdot \hat{\mathbf{r}} = \sigma_{rr} = -p + 2\mu \frac{\partial u_r}{\partial r}, \quad (5.373a)$$

$$\mathbf{t}_{\hat{\boldsymbol{\phi}}} \cdot \hat{\boldsymbol{\phi}} = \sigma_{\phi\phi} = -p + 2\mu \left(\frac{1}{r} \frac{\partial u_\phi}{\partial \phi} + \frac{u_r}{r} \right), \quad (5.373b)$$

$$\mathbf{t}_{\hat{\mathbf{z}}} \cdot \hat{\mathbf{z}} = \sigma_{zz} = -p + 2\mu \frac{\partial u_z}{\partial z}, \quad (5.373c)$$

$$\mathbf{t}_{\hat{\mathbf{r}}} \cdot \hat{\boldsymbol{\phi}} = \sigma_{r\phi} = \mu \left(\frac{\partial u_\phi}{\partial r} + \frac{1}{r} \frac{\partial u_r}{\partial \phi} - \frac{u_\phi}{r} \right), \quad (5.373d)$$

$$\mathbf{t}_{\hat{\boldsymbol{\phi}}} \cdot \hat{\mathbf{z}} = \sigma_{\phi z} = \mu \left(\frac{1}{r} \frac{\partial u_z}{\partial \phi} + \frac{\partial u_\phi}{\partial z} \right), \quad (5.373e)$$

$$\mathbf{t}_{\hat{\mathbf{z}}} \cdot \hat{\mathbf{r}} = \sigma_{zr} = \mu \left(\frac{\partial u_r}{\partial z} + \frac{\partial u_z}{\partial r} \right), \quad (5.373f)$$

so we have

$$\sigma_{rr} = \sigma_{\phi\phi} = \sigma_{zz} = -p, \quad (5.374a)$$

$$\sigma_{\phi z} = \sigma_{zr} = 0, \quad (5.374b)$$

$$\sigma_{r\phi} = \mu \left(\frac{\partial u_\phi}{\partial r} - \frac{u_\phi}{r} \right). \quad (5.374c)$$

We want to expand the last of these

$$\begin{aligned}
 \sigma_{r\phi} &= \mu \left(\frac{\partial u_\phi}{\partial r} - \frac{u_\phi}{r} \right) \\
 &= \mu \left(ar + \frac{b}{r} \right)' \\
 &= \mu \left(a - \frac{b}{r^2} \right).
 \end{aligned} \tag{5.375}$$

So the traction vector $\mathbf{t}_1 = \boldsymbol{\sigma} \cdot \hat{\mathbf{r}} = \mathbf{e}_i \sigma_{ij} \hat{\mathbf{r}} \cdot \mathbf{e}_i$, our force per unit area on the fluid at the inner surface (where the normal is $\hat{\mathbf{r}}$), is

$$\begin{aligned}
 \mathbf{t}_1 &= -p\hat{\mathbf{r}} + \mu \left(a - \frac{b}{r^2} \right) \hat{\boldsymbol{\phi}} \\
 &= -p\hat{\mathbf{r}} + \frac{\mu}{R_2^2 - R_1^2} \left(R_2^2 \Omega_2 - R_1^2 \Omega_1 + \frac{R_1^2 R_2^2}{r^2} (\Omega_2 - \Omega_1) \right) \hat{\boldsymbol{\phi}},
 \end{aligned} \tag{5.376}$$

so the torque per unit area from the inner cylinder on the fluid is

$$\boldsymbol{\tau}_1 = r\hat{\mathbf{r}} \times \mathbf{t}_1 = \frac{r\mu}{R_2^2 - R_1^2} \left(R_2^2 \Omega_2 - R_1^2 \Omega_1 + \frac{R_1^2 R_2^2}{r^2} (\Omega_2 - \Omega_1) \right) \hat{\mathbf{z}}. \tag{5.377}$$

Observing that our stress tensors flip sign for an inwards normal, our torque per unit area from the outer cylinder on the fluid is

$$\boldsymbol{\tau}_2 = r\hat{\mathbf{r}} \times (-\mathbf{t}_1) = -\frac{r\mu}{R_2^2 - R_1^2} \left(R_2^2 \Omega_2 - R_1^2 \Omega_1 + \frac{R_1^2 R_2^2}{r^2} (\Omega_2 - \Omega_1) \right) \hat{\mathbf{z}}. \tag{5.378}$$

For the complete torque on the fluid due to a strip of width Δz the magnitudes of the total torque from each cylinder are respectively

$$\boldsymbol{\tau}_1 = \frac{2\pi r^2 \Delta z \mu}{R_2^2 - R_1^2} \left(R_2^2 \Omega_2 - R_1^2 \Omega_1 + \frac{R_1^2 R_2^2}{r^2} (\Omega_2 - \Omega_1) \right) \hat{\mathbf{z}}, \tag{5.379}$$

$$\boldsymbol{\tau}_2 = -\frac{2\pi r^2 \Delta z \mu}{R_2^2 - R_1^2} \left(R_2^2 \Omega_2 - R_1^2 \Omega_1 + \frac{R_1^2 R_2^2}{r^2} (\Omega_2 - \Omega_1) \right) \hat{\mathbf{z}}. \tag{5.380}$$

As expected these torques on the fluid sum to zero

$$\boldsymbol{\tau}_2 + \boldsymbol{\tau}_1 = 0. \tag{5.381}$$

Evaluating these at R_1 and R_2 respectively gives us the torques on the fluid by the cylinders. However, we want the torques on the cylinders by the fluid, so have to flip the signs. For the inner cylinder the total torque on a strip of width Δz by the fluid is

$$\begin{aligned} & \text{Torque on inner cylinder (1) by the fluid} \\ &= -\frac{2\pi R_1^2 \Delta z \mu}{R_2^2 - R_1^2} \left(R_2^2 \Omega_2 - R_1^2 \Omega_1 + \frac{R_1^2 R_2^2}{R_1^2} (\Omega_2 - \Omega_1) \right) \quad (5.382) \\ &= \frac{2\pi R_1^2 \Delta z \mu}{R_2^2 - R_1^2} (-2R_2^2 \Omega_2 + (R_1^2 + R_2^2) \Omega_1). \end{aligned}$$

For the outer cylinder the total torque on a strip of width Δz by the fluid is

$$\begin{aligned} & \text{Torque on outer cylinder (2) by the fluid} \\ &= \frac{2\pi R_2^2 \Delta z \mu}{R_2^2 - R_1^2} \left(R_2^2 \Omega_2 - R_1^2 \Omega_1 + \frac{R_1^2 R_2^2}{R_2^2} (\Omega_2 - \Omega_1) \right) \quad (5.383) \\ &= \frac{2\pi R_2^2 \Delta z \mu}{R_2^2 - R_1^2} (-2R_1^2 \Omega_1 + (R_1^2 + R_2^2) \Omega_2). \end{aligned}$$

Here are some plots of the velocities at different values for the outer cylinder angular velocity. These were all generated from

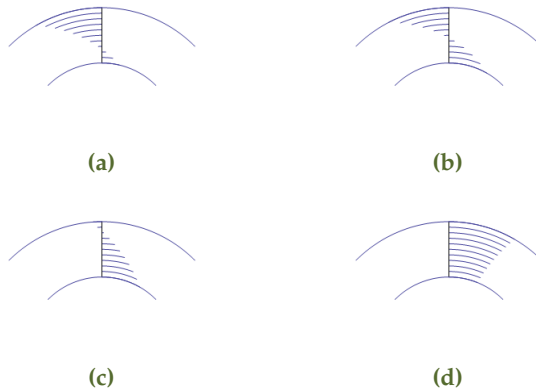

Figure 5.34: Couette flow plots.

the Mathematica workbook ([couetteFlow.cdf](#)), which has some slider controls that can be used to play with the radii and angular velocities in an interactive fashion.

Exercise 5.13 **Infinite cylinders, one moving.** (2009 phy1530 final)

An infinite cylinder of radius R_1 is moving with velocity v parallel to its axis. It is placed inside another cylinder of radius R_2 . The axes of the two cylinders coincide. The fluid is incompressible, with viscosity μ and density ρ , the flow is assumed to be stationary, and no external pressure gradient is applied.

- Find and sketch the velocity field of the fluid between the cylinders.
- Find the friction force per unit length acting on each cylinder.
- Find and sketch the pressure field of the liquid.
- If an external pressure gradient is present, how do you think your answer will change? Sketch your expectation for the velocity and pressure in this case.

Answer for Exercise 5.13

Solution Part a. Velocity. We would like to find the velocity and pressure. Let us start with the illustration of fig. 5.35 to fix coordinates. We will assume that we can find a solution of the

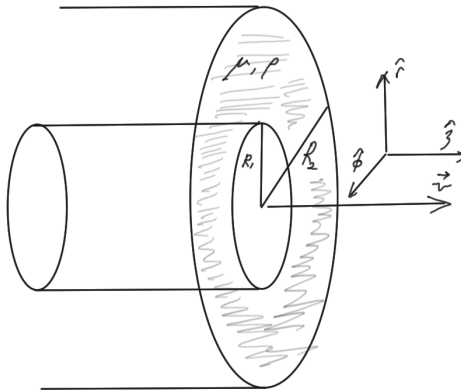

Figure 5.35: Coordinates for flow between two cylinders.

following form

$$\mathbf{u} = w(r)\hat{\mathbf{z}}, \quad (5.384a)$$

$$p = p(r). \quad (5.384b)$$

We will also work in cylindrical coordinates where our gradient is

$$\nabla = \hat{\mathbf{r}}\partial_r + \frac{\hat{\boldsymbol{\phi}}}{r}\partial_\phi + \hat{\mathbf{z}}\partial_z. \quad (5.385)$$

Let us look at the various terms of the Navier-Stokes equation. Our non-linear term is

$$\mathbf{u} \cdot \nabla \mathbf{u} = w\partial_z(w(r)\hat{\mathbf{z}}) = 0, \quad (5.386)$$

Our Laplacian term is

$$\begin{aligned} \mu \nabla^2 \mathbf{u} &= \mu \left(\frac{1}{r} \partial_r(r\partial_r) + \frac{1}{r^2} \partial_{\phi\phi} + \partial_{zz} \right) w(r)\hat{\mathbf{z}} \\ &= \frac{\mu}{r} (rw')' \hat{\mathbf{z}}. \end{aligned} \quad (5.387)$$

Putting the pieces together we have

$$0 = -\hat{\mathbf{r}}p' + \frac{\mu}{r} (rw')' \hat{\mathbf{z}}. \quad (5.388)$$

Decomposing these into one equation for each component we have

$$p' = 0, \quad (5.389)$$

and

$$(rw')' = 0. \quad (5.390)$$

Integrating once

$$rw' = A, \quad (5.391)$$

Short of satisfying our boundary value constraints our velocity is

$$w = A \ln r + B. \quad (5.392)$$

Our boundary value conditions are given by

$$\begin{aligned} w(R_2) &= 0 \\ w(R_1) &= v, \end{aligned} \quad (5.393)$$

so our integration constants are given by

$$\begin{aligned} 0 &= A \ln R_2 + B \\ v &= A \ln R_1 + B. \end{aligned} \tag{5.394}$$

Taking differences we have got

$$v = A \ln(R_1/R_2). \tag{5.395}$$

So our constants are

$$A = \frac{v}{\ln(R_1/R_2)} \tag{5.396a}$$

$$B = -\frac{v \ln R_2}{\ln(R_1/R_2)}, \tag{5.396b}$$

and

$$w(r) = \frac{v \ln(r/R_2)}{\ln(R_1/R_2)}. \tag{5.397}$$

A plot of this function can be found in fig. 5.36, and the Mathematica notebook ([twoCylinders.cdf](#)). That notebook has some slider controls that can be used interactively.

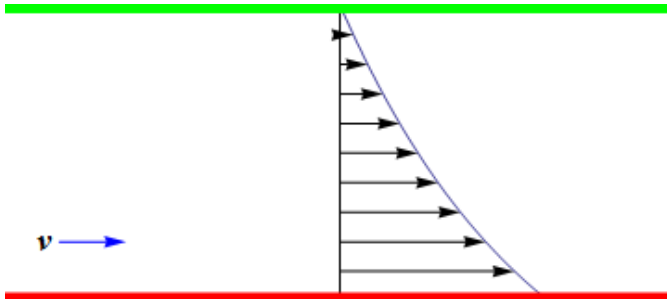

Figure 5.36: Velocity plot due to inner cylinder dragging fluid along with it.

Solution Part b. Frictional forces. For the frictional force per unit area on the fluid by the inner cylinder we have

$$\begin{aligned} (\boldsymbol{\sigma} \cdot \hat{\mathbf{r}}) \cdot \hat{\mathbf{z}} &= -p \hat{\mathbf{r}} \cdot \hat{\mathbf{z}} + 2\mu \frac{1}{2} \left(\frac{\partial u_z}{\partial r} + \frac{\partial u_r}{\partial z} \right) \\ &= \mu v \frac{\ln r}{\ln(R_1/R_2)}. \end{aligned} \tag{5.398}$$

So the forces on the inner and outer cylinders for a strip of width Δz is

$$\text{frictional force on inner cylinder} = -2\pi R_1 \Delta z \mu v \hat{\mathbf{z}} \frac{\ln R_1}{\ln(R_1/R_2)}, \quad (5.399a)$$

$$\text{frictional force on inner cylinder} = 2\pi R_2 \Delta z \mu v \hat{\mathbf{z}} \frac{\ln R_2}{\ln(R_1/R_2)}. \quad (5.399b)$$

Solution Part c. Pressure. From eq. (5.389) the pressure can be trivially solved

$$p(r) = \text{constant}, \quad (5.400)$$

Solution Part d. With external pressure gradient. With an external pressure gradient imposed we expect a superposition of a parabolic flow profile with what we have calculated above. With

$$G = -\frac{dp}{dz}, \quad (5.401)$$

our Navier-Stokes equation will now take the form

$$0 = -\hat{\mathbf{r}}p' - (-G\hat{\mathbf{z}}) + \frac{\mu}{r}(rw')'\hat{\mathbf{z}}. \quad (5.402)$$

We want to solve the LDE

$$-\frac{Gr}{\mu} = (rw')' = rw'' + w' \quad (5.403)$$

The homogeneous portion of this equation

$$(rw')' = 0, \quad (5.404)$$

we have already solved finding $w = C \ln r + D$. It looks reasonable to try a polynomial solution for the specific solution. Let us try a second order polynomial

$$w = Ar^2 + Br, \quad (5.405a)$$

$$w' = 2Ar + B, \quad (5.405b)$$

$$w'' = 2A. \quad (5.405c)$$

We need

$$-\frac{Gr}{\mu} = 2Ar + 2Ar + B. \quad (5.406)$$

So $B = 0$ and $4A = -G/\mu$, and our general solution has the form

$$w = -\frac{G}{4\mu}r^2 + C \ln r + D. \quad (5.407)$$

requiring just the boundary condition fitting. Let us tweak the constants slightly, writing

$$w = \frac{G}{4\mu}(R_2^2 - r^2) + C \ln r/R_2 + D, \quad (5.408)$$

so that $D = 0$ falls out of the $w(R_2) = 0$ constraint. Our last integration constant is then determined by the solution of

$$v = \frac{G}{4\mu}(R_2^2 - R_1^2) + C \ln R_1/R_2. \quad (5.409)$$

Or

$$w = \frac{G}{4\mu}(R_2^2 - r^2) + \left(v - \frac{G}{4\mu}(R_2^2 - R_1^2) \right) \frac{\ln r/R_2}{\ln R_1/R_2}. \quad (5.410)$$

A plot of this, with a pressure gradient small enough that we still see the logarithmic profile is shown in fig. 5.37. An animation of this with different values for R_1 , v , and $G/4\mu$ is available on <http://youtu.be/BNgpnYeRpLo>, but the Mathematica notebook above can also be used. Even cooler is to look at some plots of the velocity profiles in 3D An animation of this from ([twoCylinders3D.cdf](#)) is available [10]. That notebook is now also available online on the Wolfram demonstrations project [11].

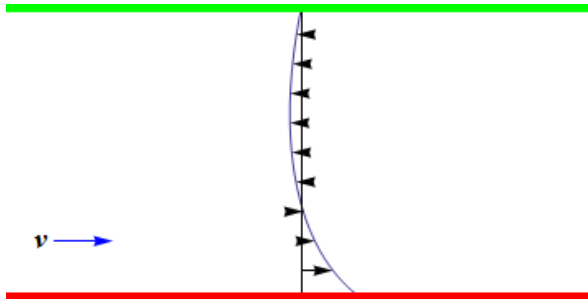

Figure 5.37: Pressure gradient added.

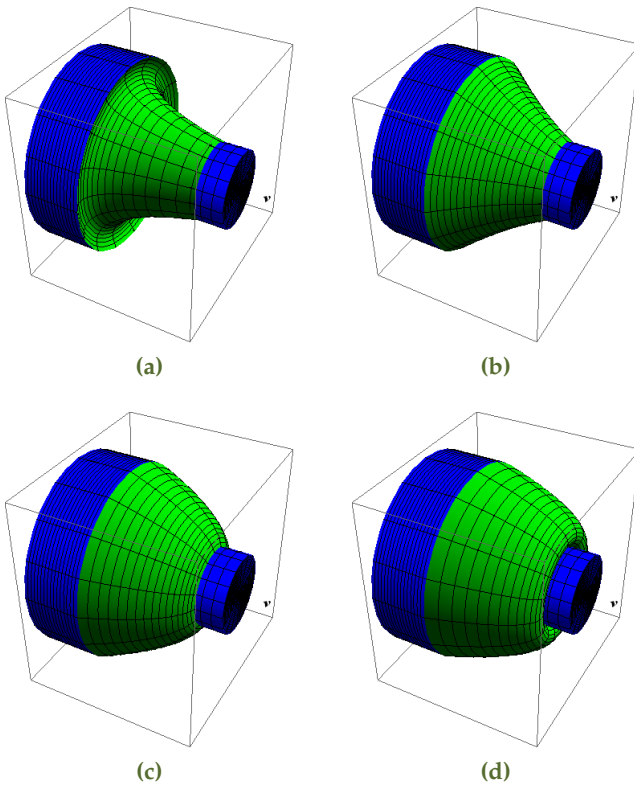

Figure 5.38: 3D plots.

6

HYDROSTATICS.

6.1 STEADY STATE AND STATIC FLUIDS.

Consider a sample volume of water, not moving with respect to the rest of the surrounding water. If it is not moving the forces must be in balance. What are the forces acting on this bit of fluid, considering a cylinder of the fluid above it as in fig. 6.1 In the

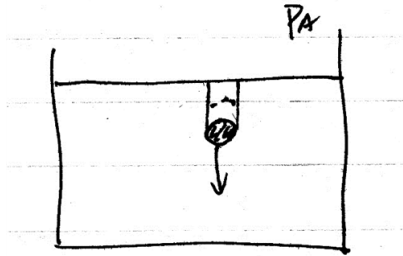

Figure 6.1: A control volume of fluid in a fluid.

column of fluid above the control volume fig. 6.2 we have

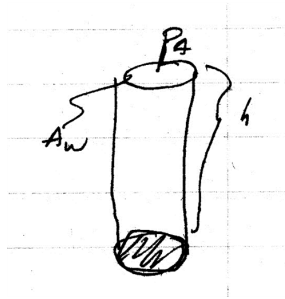

Figure 6.2: Column of fluid above a control volume.

$$hA_w\rho g + p_A A_w = p_w A_w, \quad (6.1)$$

so

$$p_w = h\rho g + p_A. \quad (6.2)$$

If we were to replace this blob of water with something of equal density, it should not change the dynamics (or statics) of the situations and that would not move.

We call this the

Definition 6.1: Buoyancy force

Buoyancy force = weight of the equivalent volume of water - weight of the foreign body.

If the densities are not equal, then we would have motion of the new bit of mass as depicted in fig. 6.3 Consider a volume of

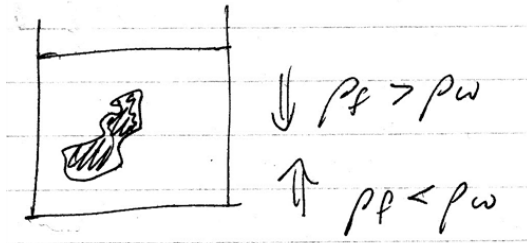

Figure 6.3: A mass of different density in a fluid.

ice floating on the surface of water, one with solid ice and one with partially frozen ice (with water or air or dirt or an anchor or anything else in it) as in fig. 6.4 No matter the situation, the water

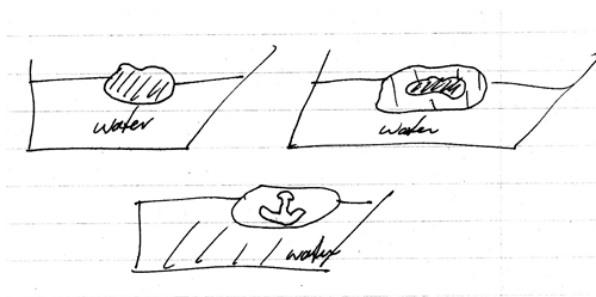

Figure 6.4: Various floating ice configurations on water.

level will not change if the ice melts, because the total weight of

the displaced water must have been matched by the weight of the unmelted ice plus additives.

Now what happens when we have fluid flows? Consider fig. 6.5 Conservation of mass is going to mean that the masses of fluid

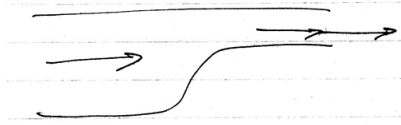

Figure 6.5: Flow through channel with different apertures.

flowing through any pair of cross sections will have to be equal

$$\rho_1 A_1 v_1 = \rho_2 A_2 v_2, \quad (6.3)$$

With incompressible fluids ($\rho = \rho_1 = \rho_2$) we have

$$A_1 v_1 = A_2 v_2, \quad (6.4)$$

so that if

$$A_1 > A_2, \quad (6.5)$$

we must have

$$v_1 < v_2, \quad (6.6)$$

to balance this.

In class this was illustrated with a pair of computer animations, one showing the deformation of patches of the fluid, and another showing how the velocities vary through the channel. This is crudely depicted in fig. 6.6 We see the same behavior for channels



Figure 6.6: Area and velocity flows in unequal aperture channel configuration.

that return to the original diameter after widening as in fig. 6.7 If

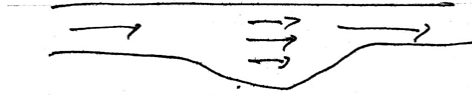

Figure 6.7: Velocity variation in channel with bulge.

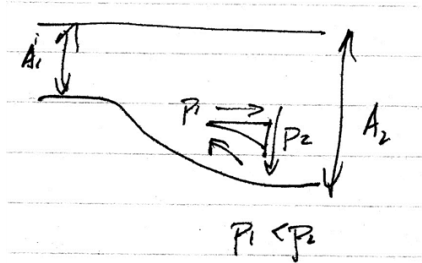

Figure 6.8: Vorticity induction due to pressure gradients in unequal aperture channel.

we consider half of such a channel as in fig. 6.8 considering the flow around a small triangular section we must have a pressure gradient, which induces a vorticity flow. We would see something similar in a rectangular channel where there is a block in the channel, as depicted in fig. 6.9

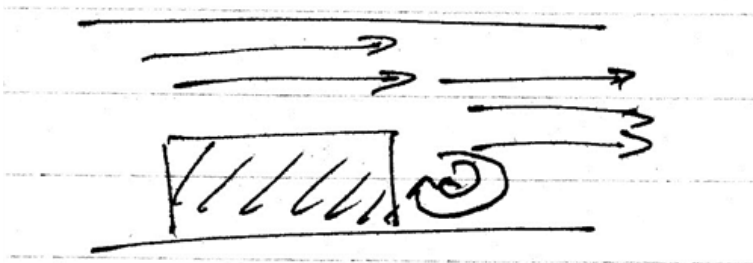

Figure 6.9: Vorticity due to rectangular blockage.

6.2 HEIGHT MATCHING IN ODD GEOMETRIES.

Let us consider an arbitrarily weird channel as in fig. 6.10 This was also illustrated with a glass blown container in class as in fig. 6.11

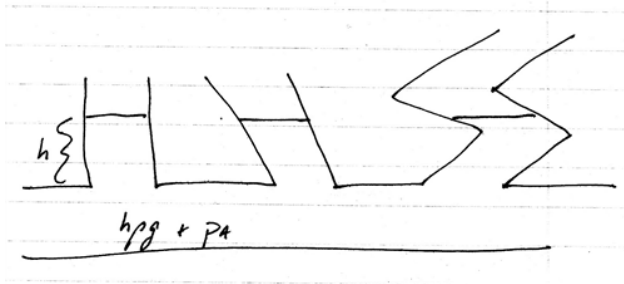

Figure 6.10: Height matching in odd geometries.

In this real apparatus, we did not have exactly the same height

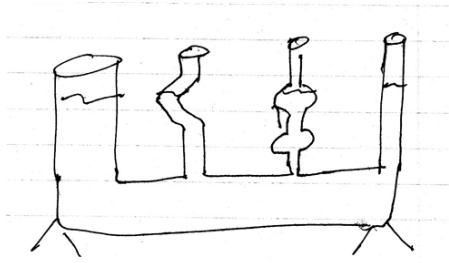

Figure 6.11: A physical demonstration with glass blown apparatus.

(because of bubbles and capillary effects (surface tension induced meniscus curves), but we see first hand what we are talking about.

To account for this, we need to consider the situation in pieces as in fig. 6.12 Breaking down the total pressure effects into individual bits, any column of fluid contributes to the pressure below it, even if that column of fluid is not directly on top of a continuous column of fluid all the way to the “bottom”.

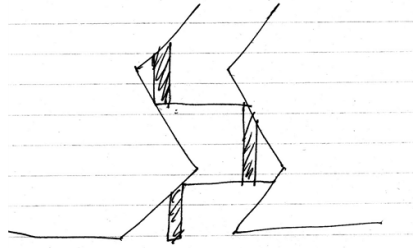

Figure 6.12: Column volume element decomposition for odd geometries.

6.3 SUMMARY.

6.3.1 *Hydrostatics.*

We covered hydrostatics as a separate topic, where it was argued that the pressure p in a fluid, given atmospheric pressure p_a and height from the surface was

$$p = p_a + \rho gh. \quad (6.7)$$

As noted below in the surface tension problem, this is also a consequence of Navier-Stokes for $\mathbf{u} = 0$ (following from $0 = -\nabla p + \rho\mathbf{g}$).

We noted that replacing the a mass of water with something of equal density would not change the non-dynamics of the situation. We then went on to define Buoyancy force, the difference in weight of the equivalent volume of fluid and the weight of the object.

6.3.2 *Mass conservation through apertures.*

It was noted that mass conservation provides a relationship between the flow rates through apertures in a closed pipe, since we must have

$$\rho_1 A_1 v_1 = \rho_2 A_2 v_2, \quad (6.8)$$

and therefore for incompressible fluids

$$A_1 v_1 = A_2 v_2. \quad (6.9)$$

So if $A_1 > A_2$ we must have $v_1 < v_2$.

7

BERNOULLI'S THEOREM.

7.1 DERIVATION.

We start with Navier-Stokes in vector form

$$\frac{\partial \mathbf{u}}{\partial t} + (\mathbf{u} \cdot \nabla) \mathbf{u} = -\nabla \left(\frac{p}{\rho} \right) + \nu \nabla^2 \mathbf{u} + \mathbf{g}. \quad (7.1)$$

Writing the body force as a potential

$$\mathbf{g} = -\nabla \chi, \quad (7.2)$$

so that we have

$$\frac{\partial \mathbf{u}}{\partial t} + (\mathbf{u} \cdot \nabla) \mathbf{u} = -\nabla \left(\frac{p}{\rho} + \chi \right) + \nu \nabla^2 \mathbf{u}. \quad (7.3)$$

Using the vector identity

$$(\mathbf{u} \cdot \nabla) \mathbf{u} = \nabla \times (\nabla \times \mathbf{u}) + \nabla \left(\frac{1}{2} \mathbf{u}^2 \right), \quad (7.4)$$

we can write

$$\frac{\partial \mathbf{u}}{\partial t} + \nabla \times (\nabla \times \mathbf{u}) + \nabla \left(\frac{1}{2} \mathbf{u}^2 \right) = -\nabla \left(\frac{p}{\rho} + \chi \right) + \nu \nabla^2 \mathbf{u}. \quad (7.5)$$

If we consider the non-viscous region of the flow (far from the boundary layer), we can kill the Laplacian term. Again, considering only the steady state, and assuming that we have irrotational flow ($\nabla \times \mathbf{u} = 0$) in the non-viscous region, we have

$$\nabla \left(\frac{p}{\rho} + \chi + \frac{1}{2} \mathbf{u}^2 \right) = 0. \quad (7.6)$$

or

$$\boxed{\frac{p}{\rho} + \chi + \frac{1}{2} \mathbf{u}^2 = \text{constant}.} \quad (7.7)$$

This is Bernoulli's equation.

On streamlines The derivation of Bernoulli's equation in §5 of [12] does not mention irrotational flow. The statement of Bernoulli's theorem in [3] is similar, related only to streamlines, with irrotational flow considered later as a special case. The Landau derivation considers steady state flows along streamlines, and argues that since the velocities are tangential to any streamline, and because $\mathbf{u} \times (\nabla \times \mathbf{u})$ is perpendicular to \mathbf{u} , the projection of that curl term on the streamline direction is zero. That leaves a zero for the projection of the gradient along the streamline direction

$$\nabla \left(\frac{p}{\rho} + \chi + \frac{1}{2} \mathbf{u}^2 \right), \quad (7.8)$$

From this eq. (7.7) is a statement that the quantity in the gradient operation is constant along any streamline, even for rotational flows.

Observe that the general form of Bernoulli's theorem follows from the fact that

$$\mathbf{u} \cdot (\mathbf{u} \times (\nabla \times \mathbf{u})) = 0, \quad (7.9)$$

where the mathematical statement of the theorem is

$$\boxed{(\mathbf{u} \cdot \nabla) \left(\frac{p}{\rho} + \chi + \frac{1}{2} \mathbf{u}^2 \right) = 0.} \quad (7.10)$$

The operation $\mathbf{u} \cdot \nabla$ is the projection of the gradient onto the streamline (i.e. the lines formed from the tangents to the velocities along the steady state flow paths). Along those lines eq. (7.7) hold, where the constant can be streamline dependent.

7.2 SUMMARY.

7.2.1 Bernoulli equation.

With the body force specified in gradient for

$$\mathbf{g} = -\nabla \chi, \quad (7.11)$$

and utilizing the vector identity

$$(\mathbf{u} \cdot \nabla) \mathbf{u} = \nabla \times (\nabla \times \mathbf{u}) + \nabla \left(\frac{1}{2} \mathbf{u}^2 \right), \quad (7.12)$$

we are able to show that the steady state, irrotational, non-viscous Navier-Stokes equation takes the form

$$\nabla \left(\frac{p}{\rho} + \chi + \frac{1}{2} \mathbf{u}^2 \right) = 0, \quad (7.13)$$

or

$$\frac{p}{\rho} + \chi + \frac{1}{2} \mathbf{u}^2 = \text{constant}. \quad (7.14)$$

This is the Bernoulli equation, and the constants introduce the concept of streamline.

7.3 PROBLEMS.

Exercise 7.1 Surface for spinning bucket of water. (2009 phy1530 final)

Here's a problem that serves as a nice example of how to determine a surface as a function of pressure. This is something I want to do for the non-bottomless coffee problem, so let's try a simpler version first.

An undergraduate student is assigned a problem about an ideal fluid rotating at a constant angular velocity Ω under gravity g . The velocity field is $\mathbf{u} = (-\Omega y, \Omega x, 0)$. Here, x and y are horizontal and z points up. The student is supposed to find the surfaces of constant pressure, and hence the shape of the free surface of water in a rotating bucket. The free surface corresponds to the surface for which $p = p_0$, where p_0 is the atmospheric pressure. Surface tension is neglected.

On their homework assignment, the student writes:

"By Bernoulli's equation:

$$B = \frac{p}{\rho} + \frac{1}{2} u^2 + gz, \quad (7.15)$$

where B is a constant. So the constant pressure surface at $p = p_0$ is

$$z = \left(\frac{B}{g} - \frac{p_0}{\rho g} \right) - \frac{\Omega^2}{2g} (x^2 + y^2). \quad (7.16)$$

"

But this seems to show that the surface of the water in a rotating bucket is *highest in the middle!*

- a. What is wrong with the student's argument?
- b. Write down the Euler equations in component form and integrate them directly to find the pressure p , and hence obtain the correct parabolic shape for the free surface.

Answer for Exercise 7.1

Solution Part a. Problem with the argument. Let us recall how we derived Bernoulli's theorem. We started with Navier-Stokes and used the identity

$$(\mathbf{u} \cdot \nabla)\mathbf{u} = \nabla \frac{1}{2}\mathbf{u}^2 + (\nabla \times \mathbf{u}) \times \mathbf{u}. \quad (7.17)$$

Navier-Stokes for a steady state incompressible flow, with external body force per unit volume $\rho\mathbf{g} = -\rho\nabla\chi$ take the form

$$\nabla \frac{1}{2}\mathbf{u}^2 + (\nabla \times \mathbf{u}) \times \mathbf{u} = -\frac{1}{\rho}\nabla p + \nu\nabla^2\mathbf{u} - \nabla\chi. \quad (7.18)$$

For the non-viscous ("dry-water") case where we take $\mu = \nu\rho = 0$, and treat the density ρ as a constant we find

$$\mathbf{u} \times (\nabla \times \mathbf{u}) = \nabla \left(\frac{1}{2}\mathbf{u}^2 + \frac{p}{\rho} + \chi \right). \quad (7.19)$$

Observe that we only arrive at Bernoulli's theorem if the flow is also irrotational (as well as incompressible and non-viscous), as we require an irrotational flow where $\nabla \times \mathbf{u} = 0$ to claim that the gradient on the RHS is zero.

In this problem we do not have an irrotational flow, which can be demonstrated by direct calculation. We have

$$\begin{aligned} \nabla \times \mathbf{u} &= \Omega \begin{vmatrix} \hat{x} & \hat{y} & \hat{z} \\ \partial_x & \partial_y & 0 \\ -y & x & 0 \end{vmatrix} \\ &= 2\hat{z}\Omega \\ &\neq 0. \end{aligned} \quad (7.20)$$

In fact we have

$$\begin{aligned} \mathbf{u} \times (\nabla \times \mathbf{u}) &= 2\Omega^2 \begin{vmatrix} \hat{x} & \hat{y} & \hat{z} \\ -y & x & 0 \\ 0 & 0 & 1 \end{vmatrix} \\ &= 2\Omega^2(\hat{x} + \hat{y}). \end{aligned} \quad (7.21)$$

The closest we can get to Bernoulli's theorem for this problem is

$$2\Omega^2(\hat{\mathbf{x}} + \hat{\mathbf{y}}) = \nabla \left(\frac{1}{2}\mathbf{u}^2 + \frac{p}{\rho} + gz \right). \quad (7.22)$$

We can say that the directional derivatives in directions perpendicular to $\hat{\mathbf{x}} + \hat{\mathbf{y}}$ are zero, and that

$$\begin{aligned} 2\Omega^2 &= (\partial_x + \partial_y) \left(\frac{1}{2}\mathbf{u}^2 + \frac{p}{\rho} + gz \right) \\ &= (\partial_x + \partial_y) \left(\frac{1}{2}\mathbf{u}^2 + \frac{p}{\rho} \right). \end{aligned} \quad (7.23)$$

Perhaps those could be used to solve for the surface, but we no longer have something that is obviously integrable.

Because $\mathbf{u} \cdot (\mathbf{u} \times (\nabla \times \mathbf{u})) = 0$, we can also say that

$$\begin{aligned} 0 &= \mathbf{u} \cdot \nabla \left(\frac{1}{2}\mathbf{u}^2 + \frac{p}{\rho} + gz \right) \\ &= \Omega(y\partial_x - x\partial_y) \left(\frac{1}{2}\mathbf{u}^2 + \frac{p}{\rho} \right). \end{aligned} \quad (7.24)$$

Perhaps this could also be used to find the surface?

Streamline interpretation. In [12] we find that Bernoulli's equation applies not only to irrotational flows, but is valid along the streamlines of the flow as well. The streamlines for this rotating bucket system can be expressed nicely using polar coordinates. Let

$$\begin{aligned} x &= \rho \cos \theta \\ y &= \rho \sin \theta. \end{aligned} \quad (7.25)$$

The velocity field, plotted in fig. 7.1, is

$$\mathbf{u} = \Omega\rho(-\sin \theta, \cos \theta, 0). \quad (7.26)$$

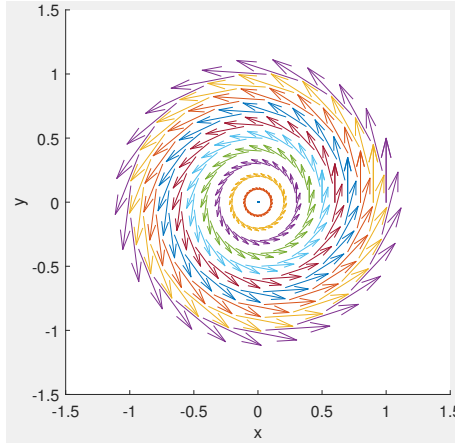

Figure 7.1: Streamlines for the rotating bucket system.

Observe that the cross term $\mathbf{u} \times (\nabla \times \mathbf{u})$, are the normals to the streamlines.

Solution Part b. Solving Navier-Stokes. Now we want to write down the steady state, incompressible, non-viscous Navier-Stokes equations. The first of these is trivially satisfied by our assumed solution

$$\begin{aligned} 0 &= \nabla \cdot \mathbf{u} \\ &= \partial_x(-\Omega y) + \partial_y(\Omega x). \end{aligned} \quad (7.27)$$

For the inertial term we have got

$$\begin{aligned} \mathbf{u} \cdot \nabla \mathbf{u} &= \Omega^2(-y\partial_x + x\partial_y)(-y, x, 0) \\ &= \Omega^2(-x, -y, 0), \end{aligned} \quad (7.28)$$

leaving us with

$$\begin{aligned} -\Omega^2 x &= -\frac{1}{\rho} \partial_x p - \Omega^2 y \\ &= -\frac{1}{\rho} \partial_y p \\ &= -\frac{1}{\rho} \partial_z p - g. \end{aligned} \quad (7.29)$$

Integrating these, we seek simultaneous solutions to

$$\begin{aligned} p &= \frac{1}{2}\rho\Omega^2x^2 + f(y, z) \\ &= \frac{1}{2}\rho\Omega^2y^2 + g(x, z) \\ &= h(x, y) - \rho gz. \end{aligned} \tag{7.30}$$

It is clear that one solution would be

$$p = p_0 + \frac{1}{2}\rho\Omega^2(x^2 + y^2) - \rho gz. \tag{7.31}$$

where p_0 is some constant to be determined, dependent on where we set our origin. Putting the origin of the coordinate system at the lowest point in the parabolic profile $(x, y, z) = (0, 0, 0)$, we have $p(0, 0, 0) = p_0$, which fixes p_0 as the atmospheric pressure. If the radius of the bucket is R , the max height h of the surface above that point is also found on this surface of constant pressure

$$p_0 = p_0 + \frac{1}{2}\rho\Omega^2R^2 - \rho gh, \tag{7.32}$$

or

$$h = \frac{\Omega^2R^2}{2g}. \tag{7.33}$$

Exercise 7.2 Curve for tap discharge.

Use Bernoulli's theorem to get a rough idea what the curve for water coming out a tap would be.

Answer for Exercise 7.2

Suppose we measure the volume flux, putting a measuring cup under the tap, and timing how long it takes to fill up. We then measure the radii at different points. This can be done from a photo as in fig. 7.2. After making the measurement, we can get an idea of the velocity between two points given a velocity estimate at a point higher in the discharge. For a plain old falling mass, our final velocity at a point measured from where the velocity was originally measured can be found from Newton's law

$$\Delta v = gt \tag{7.34}$$

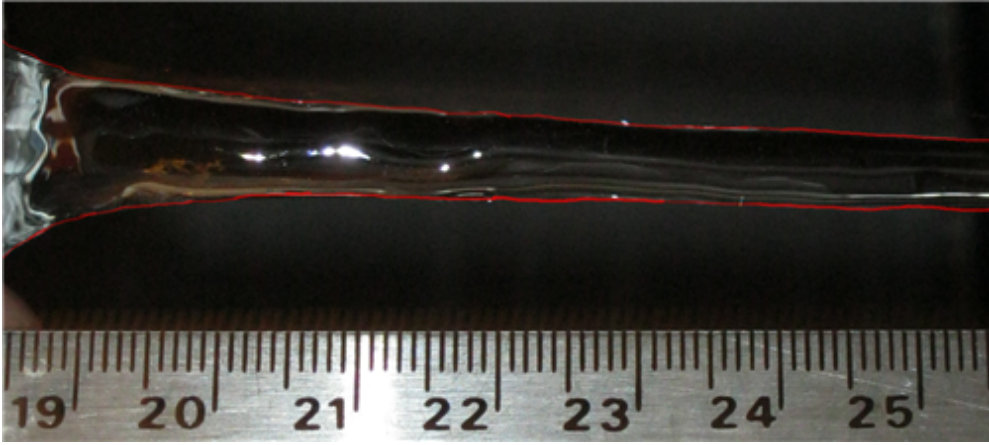

Figure 7.2: Tap flow measurement.

$$\Delta z = \frac{1}{2}gt^2 + v_0t. \quad (7.35)$$

Solving for $v_f = v_0 + \Delta v$, we find

$$v_f = v_0 \sqrt{1 + \frac{2g\Delta z}{v_0^2}}. \quad (7.36)$$

Mass conservation gives us

$$v_0\pi R^2 = v_f\pi r^2, \quad (7.37)$$

or

$$r(\Delta z) = R \sqrt{\frac{v_0}{v_f}} = R \left(1 + \frac{2g\Delta z}{v_0^2}\right)^{-1/4}. \quad (7.38)$$

For the image above I measured a flow rate of about 250 ml in 10 seconds. With that, plus the measured radii at 0 and 6cm, I calculated that the average fluid velocity was 0.9m/s, vs a free fall rate increase of 1.3m/s. Not the best match in the world, but that is to be expected since the velocity has been considered uniform throughout the stream profile, which would not actually be the case. A proper treatment would also have to treat viscosity and surface tension.

In fig. 7.3 is a plot of the measured radial distance compared to what was computed with eq. (7.38). The blue line is the measured width of the stream as measured, the red is a polynomial curve fitted to the raw data, and the green is the computed curve above.

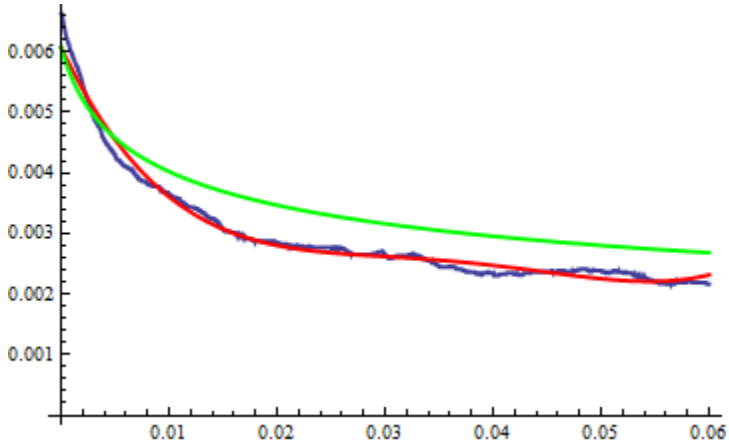

Figure 7.3: Comparison of measured stream radii and calculated.

8

SURFACE TENSION.

8.1 TRACTION VECTOR AT THE INTERFACE.

For a surface like fig. 8.1 we have a discontinuous jump in density.

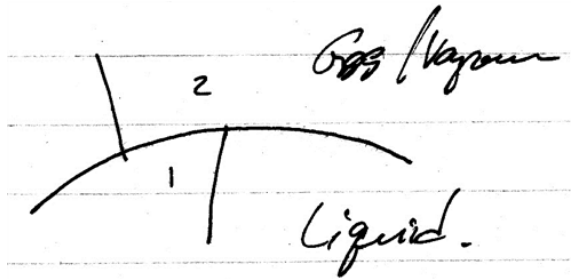

Figure 8.1: Vapor liquid interface.

We will have to consider three boundary value constraints

1. Mass balance. This is the continuity equation.
2. Momentum balance. This is the Navier-Stokes equation.
3. Energy balance. This is the heat equation.

We have not yet discussed the heat equation, but this is required for non-isothermal problems.

We will define

σ = surface tension

R = radius of curvature (8.1)

∇_I = gradient along the interface

and consider the boundary condition at the interface. Note that we are switching notations for the stress tensor since we will be using σ for surface tension here.

Performing a stress balance at the interface, we express the difference in the traction vector here by

$$[\mathbf{t}]_1^2 = \mathbf{t}_2 - \mathbf{t}_1 = -\frac{\sigma}{2R} \hat{\mathbf{n}} - \nabla_I \sigma. \tag{8.2}$$

The suffix 2 and prefix 1 indicates that we are considering the interface between fluids labeled 1 and 2 (liquid and air respectively in the diagram).

Here the gradient is in the tangential direction of the surface as in fig. 8.2. In the normal direction

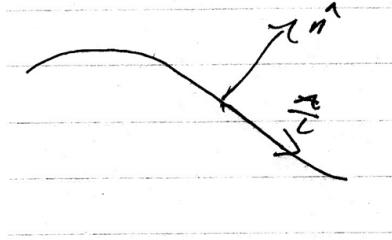

Figure 8.2: Normal and tangent vectors on a curve.

$$\begin{aligned} [\mathbf{t}]_1^2 \cdot \hat{\mathbf{n}} &= (\mathbf{t}_2 - \mathbf{t}_1) \cdot \hat{\mathbf{n}} \\ &= -\frac{\sigma}{2R}. \end{aligned} \tag{8.3}$$

With the traction vector having the value

$$\begin{aligned} \mathbf{t} &= \mathbf{e}_i T_{ij} n_j \\ &= \mathbf{e}_i \left(-p \delta_{ij} + \mu \left(\frac{\partial u_i}{\partial x_j} + \frac{\partial u_j}{\partial x_i} \right) \right) n_j. \end{aligned} \tag{8.4}$$

We have in the normal direction

$$\mathbf{t} \cdot \mathbf{n} = n_i \left(-p \delta_{ij} + \mu \left(\frac{\partial u_i}{\partial x_j} + \frac{\partial u_j}{\partial x_i} \right) \right) n_j. \tag{8.5}$$

With $\mathbf{u} = 0$ on the surface, and $n_i \delta_{ij} n_j = n_j n_j = 1$ we have

$$\mathbf{t} \cdot \mathbf{n} = -p. \tag{8.6}$$

Returning to $(\mathbf{t}_2 - \mathbf{t}_1) \cdot \hat{\mathbf{n}}$ we have

$$-p_2 + p_1 = -\frac{\sigma}{2R}. \quad (8.7)$$

This is the Laplace pressure. Note that the sign of the difference is significant, since it effects the direction of the curvature. This is depicted pictorially in fig. 8.3 Note that in [12] the curvature term

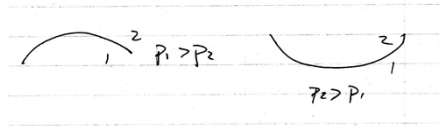

Figure 8.3: Pressure and curvature relationships.

is written

$$\frac{1}{2R} \rightarrow \frac{1}{R_1} + \frac{1}{R_2}. \quad (8.8)$$

The second radius of curvature is to account for non-spherical surfaces, where we have curvature in two directions. Illustrating by example, imagine a surface like as in fig. 8.4

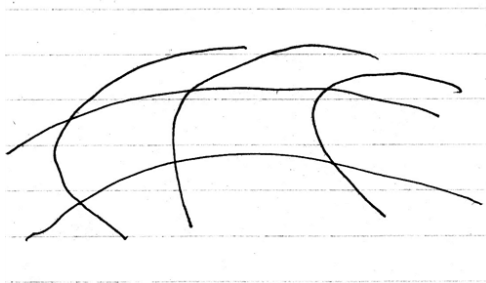

Figure 8.4: Example of non-spherical curvature.

Reading: An treatment of this topic that looks complete enough to understand looks like it can be found in §7 of [12].

8.2 SURFACE TENSION GRADIENTS.

Now consider the tangential component of the traction vector

$$\mathbf{t}_2 \cdot \hat{\mathbf{t}} - \mathbf{t}_1 \cdot \hat{\mathbf{t}} = -\frac{\sigma}{2R} \hat{\mathbf{n}} \cdot \hat{\mathbf{t}} - \hat{\mathbf{t}} \cdot \nabla_I \sigma. \quad (8.9)$$

So we see that for a static fluid, we must have

$$\nabla_I \sigma = 0. \quad (8.10)$$

For a static interface there cannot be any surface tension gradient. This becomes very important when considering stability issues. We can have surface tension induced flow called capillary, or mandarin (?) flow.

8.3 SUMMARY.

8.3.1 Laplace pressure.

It was argued in class that the traction vector differences at the surfaces between a pair of fluids have the form

$$\mathbf{t}_2 - \mathbf{t}_1 = -\frac{\sigma}{2R} \hat{\mathbf{n}} - \nabla_I \sigma, \quad (8.11)$$

where $\nabla_I = \nabla - \hat{\mathbf{n}}(\hat{\mathbf{n}} \cdot \nabla)$ is the tangential (interfacial) gradient, σ is the surface tension, a force per unit length value, and R is the radius of curvature.

In static equilibrium where $\mathbf{t} = -p\hat{\mathbf{n}}$ (since $\sigma = 0$ if $\mathbf{u} = 0$), then dotting with $\hat{\mathbf{n}}$ we must then have

$$p_2 - p_1 = \frac{\sigma}{2R}. \quad (8.12)$$

Reading: [12] covers this topic in typical fairly hard to comprehend detail, but there is lots of valuable info there. §2.4.9-2.4.10 of [7] also has small section that is a bit easier to understand, with less detail. Recommended in that text is the “Surface Tension in Fluid Mechanics” movie [6], which is very interesting and entertaining to watch.

8.3.2 Surface tension gradients.

Considering the tangential component of the traction vector difference we find

$$(\mathbf{t}_2 - \mathbf{t}_1) \cdot \hat{\boldsymbol{\tau}} = -\hat{\boldsymbol{\tau}} \cdot \nabla_I \sigma. \quad (8.13)$$

If the fluid is static (for example, has none of the creep that we see in the film) then we must have $\nabla_I \sigma = 0$. It is these gradients that are responsible for capillary flow and other related surface tension driven motion (lots of great examples of that in the film).

8.3.3 *Surface tension for a spherical bubble.*

In the film above it is pointed out that the surface tension equation we were shown in class

$$\Delta p = \frac{2\sigma}{R}, \quad (8.14)$$

is only for spherical objects that have a single radius of curvature. This formula can in fact be derived with a simple physical argument, stating that the force generated by the surface tension σ along the equator of a bubble (as in fig. 8.5), in a fluid would be balanced by the difference in pressure times the area of that equatorial cross section. That is

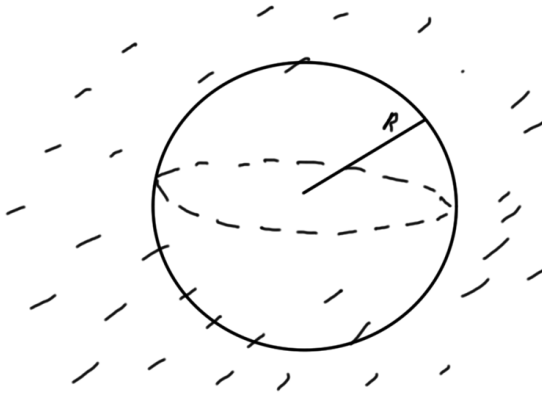

Figure 8.5: Spherical bubble in liquid.

$$\sigma 2\pi R = \Delta p \pi R^2. \quad (8.15)$$

Observe that we obtain eq. (8.14) after dividing through by the area.

8.4 PROBLEMS.

Exercise 8.1 Meniscus curve against one wall.

As an application of our surface tension results, solve for the shape of a meniscus of water against a wall. Work from the brief solution found in [12] and add sufficient details that the solution can be understood more easily.

Answer for Exercise 8.1

As in the text we will work with z axis up, and the fluid up against a wall at $x = 0$ as illustrated in fig. 8.6. To get some idea a better feeling for , let us look to a worked problem. The starting

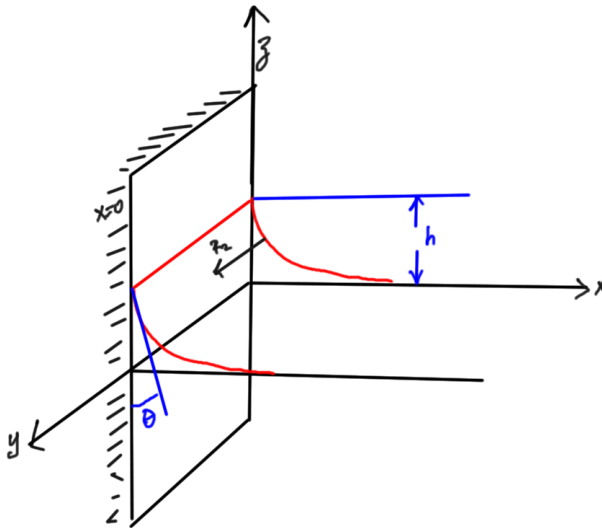

Figure 8.6: Curvature of fluid against a wall.

point is a variation of what we have in class

$$p_1 - p_2 = \sigma \left(\frac{1}{R_1} + \frac{1}{R_2} \right), \tag{8.16}$$

where p_2 is the atmospheric pressure, p_1 is the fluid pressure, and the (signed!) radius of curvatures positive if pointing into medium 1 (the fluid).

For fluid at rest, Navier-Stokes takes the form

$$0 = -\nabla p_1 + \rho \mathbf{g}. \quad (8.17)$$

With $\mathbf{g} = -g\hat{\mathbf{z}}$ we have

$$0 = -\frac{\partial p_1}{\partial z} - \rho g, \quad (8.18)$$

or

$$p_1 = \text{constant} - \rho g z. \quad (8.19)$$

We have $p_2 = p_a$, the atmospheric pressure, so our pressure difference is

$$p_1 - p_2 = \text{constant} - \rho g z. \quad (8.20)$$

We have then

$$\text{constant} - \frac{\rho g z}{\sigma} = \frac{1}{R_1} + \frac{1}{R_2}. \quad (8.21)$$

One of our axis of curvature directions is directly along the y axis so that curvature is zero $1/R_1 = 0$. We can fix the constant by noting that at $x = \infty$, $z = 0$, we have no curvature $1/R_2 = 0$. This gives

$$\text{constant} - 0 = 0 + 0. \quad (8.22)$$

That leaves just the second curvature to determine. For a curve $z = z(x)$ our absolute curvature, according to [26] is

$$\left| \frac{1}{R_2} \right| = \frac{|z''|}{(1 + (z')^2)^{3/2}}. \quad (8.23)$$

Now we have to fix the sign. I did not recall any sort of notion of a signed radius of curvature, but there is a blurb about it on the curvature article above, including a nice illustration of signed radius of curvatures can be found in this [wikipedia radius of curvature figure for a Lemniscate](#). Following that definition for a curve such as $z(x) = (1 - x)^2$ we would have a positive curvature, but the text explicitly points out that the curvatures are will be set positive if pointing into the medium. For us to point the normal

into the medium as in the figure, we have to invert the sign, so our equation to solve for z is given by

$$-\frac{\rho g z}{\sigma} = -\frac{z''}{(1 + (z')^2)^{3/2}}. \quad (8.24)$$

The text introduces the capillary constant

$$a = \sqrt{2\sigma/g\rho}. \quad (8.25)$$

Using that capillary constant a to tidy up a bit and multiplying by a z' integrating factor we have

$$-\frac{2zz'}{a^2} = -\frac{z''z'}{(1 + (z')^2)^{3/2}}, \quad (8.26)$$

we can integrate to find

$$A - \frac{z^2}{a^2} = \frac{1}{(1 + (z')^2)^{1/2}}. \quad (8.27)$$

Again for $x = \infty$ we have $z = 0$, $z' = 0$, so $A = 1$. Rearranging we have

$$\int dx = \int dz \left(\frac{1}{(1 - z^2/a^2)^2} - 1 \right)^{-1/2}. \quad (8.28)$$

Integrating this with Mathematica I get

$$x - x_0 = \sqrt{2a^2 - z^2} \operatorname{sgn}(a - z) + \frac{a}{\sqrt{2}} \ln \left(\frac{a \left(2a - \sqrt{4a^2 - 2z^2} \operatorname{sgn}(a - z) \right)}{z} \right). \quad (8.29)$$

It looks like the constant would have to be fixed numerically. We require at $x = 0$

$$z'(0) = \frac{-\cos \theta}{\sin \theta} = -\cot \theta, \quad (8.30)$$

but we do not have an explicit function for z .

NONDIMENSIONALISATION.

9.1 SCALING.

By scaling we mean how much detail do you want to look at in the analysis. Consider the fig. 9.1 where we imagine that we zoom in on something that appears smooth from a distance. However, we are free to perform a change of variables on our coordinates and rescale in any arbitrary fashion. For example

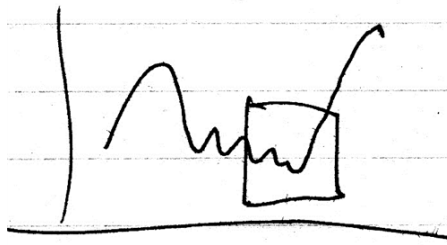

Figure 9.1: Coarse scaling example.

$$x \rightarrow Au^\alpha \tag{9.1}$$

$$y \rightarrow Bv^\beta. \tag{9.2}$$

For a linear zoom scaling ($\alpha = \beta = 1$) we could perhaps find that we have something very granular close up as in fig. 9.2. Picking the length scale to be used in this case can be very important. The flexibility to rescale with non unity values for α and β can, for example, come in handy, should we choose to rescale time and position differently.

9.2 RESCALING BY CHARACTERISTIC LENGTH AND VELOCITY.

Suppose that a fluid is flowing with

- a characteristic velocity U , with dimensions $[U] \sim LT^{-1}$

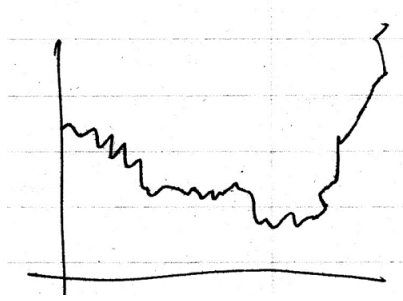

Figure 9.2: Fine grain scaling example (a zoom).

- a characteristic length scale L

Considering the dimensions of the terms in the Navier-Stokes equation

$$[\rho] = ML^{-3}, \quad (9.3)$$

$$[p] = MLT^{-2}L^{-2} = ML^{-1}T^{-2}, \quad (9.4)$$

$$[t] = T = \frac{L}{U}, \quad (9.5)$$

so

$$[p] = [\rho U^2] = ML^{-3}L^2T^{-2} = ML^{-1}T^{-2}. \quad (9.6)$$

Now let us alter the Navier-Stokes equation using some scaling to put it into a dimensionless form

$$\frac{\partial \mathbf{u}}{\partial t} + (\mathbf{u} \cdot \nabla) \mathbf{u} = -\frac{1}{\rho} \nabla p + \nu \nabla^2 \mathbf{u} \quad (9.7)$$

$$\frac{\partial \mathbf{u}}{\partial t} \rightarrow \frac{\partial(U\mathbf{u}')}{\partial(\frac{L}{U}t')} = \frac{U^2}{L} \frac{\partial \mathbf{u}'}{\partial t'} \quad (9.8)$$

$$\nabla = \hat{\mathbf{x}} \frac{\partial}{\partial x} + \hat{\mathbf{y}} \frac{\partial}{\partial y} + \hat{\mathbf{z}} \frac{\partial}{\partial z} \rightarrow \hat{\mathbf{x}} \frac{\partial}{\partial Lx'} + \hat{\mathbf{y}} \frac{\partial}{\partial Ly'} + \hat{\mathbf{z}} \frac{\partial}{\partial Lz'}, \quad (9.9)$$

so that

$$\nabla \rightarrow \frac{1}{L} \nabla' \quad (9.10)$$

$$(\mathbf{u} \cdot \nabla) \mathbf{u} \rightarrow \left(U \mathbf{u}' \cdot \frac{1}{L} \nabla' \right) U \mathbf{u}' = \frac{U^2}{L} (\mathbf{u}' \cdot \nabla') \mathbf{u}' \quad (9.11)$$

$$\frac{1}{\rho} \nabla p \rightarrow \frac{1}{L} \frac{\nabla'(\rho U^2)}{\rho} p' = \frac{U^2}{L} \nabla' p' \quad (9.12)$$

$$\nu \nabla^2 \mathbf{u} \rightarrow \frac{\nu}{L^2} \nabla' U \mathbf{u}' = \frac{\nu U}{L^2} \nabla' \mathbf{u}'. \quad (9.13)$$

Putting everything together, Navier-Stokes takes the form

$$\frac{U^2}{L} \frac{\partial \mathbf{u}'}{\partial t'} + \frac{U^2}{L} (\mathbf{u}' \cdot \nabla') \mathbf{u}' = \frac{U^2}{L} \nabla' p' + \frac{\nu U}{L^2} \nabla' \mathbf{u}', \quad (9.14)$$

or

$$\frac{\partial \mathbf{u}'}{\partial t'} + (\mathbf{u}' \cdot \nabla') \mathbf{u}' = \nabla' p' + \frac{\nu}{UL} \nabla' \mathbf{u}'. \quad (9.15)$$

Introducing the Reynold's number

$$R = \frac{LU}{\nu}. \quad (9.16)$$

We have Navier-Stokes in dimensionless form

$$\frac{\partial \mathbf{u}'}{\partial t'} + (\mathbf{u}' \cdot \nabla') \mathbf{u}' = \nabla' p' + \frac{1}{R} \nabla' \mathbf{u}'. \quad (9.17)$$

The implications of this will be discussed further in the next lecture.

Reading: Coverage of this topic (with some problems) can be found in §7.6, §7.7 of [7].

9.3 REYNOLD'S NUMBER.

In Navier-Stokes after making non-dimensionalization changes of the form

$$x \rightarrow Lx', \quad (9.18)$$

the control parameter is like Reynold's number.

In Navier-Stokes

$$\rho \frac{\partial \mathbf{u}}{\partial t} + \rho(\mathbf{u} \cdot \nabla)\mathbf{u} = -\nabla p + \mu \nabla^2 \mathbf{u}, \tag{9.19}$$

we call the term

$$\rho(\mathbf{u} \cdot \nabla)\mathbf{u}, \tag{9.20}$$

the inertial term. It is non-zero only when something is being "carried along with the velocity". Consider a volume fixed in space and one that is moving along with the fluid as in fig. 9.3 All of our

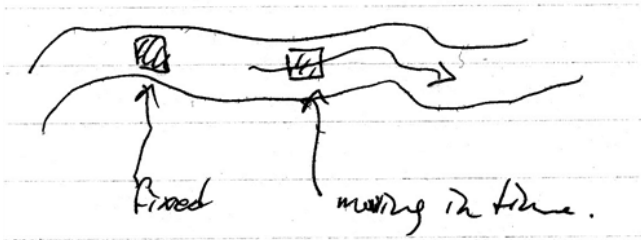

Figure 9.3: Moving and fixed frame control volumes in a fluid.

viscosity dependence shows up in the Laplacian term, so we can roughly characterize the Reynold's number as the ratio

$$\begin{aligned} \text{Reynold's number} &\rightarrow \frac{|\text{effect of inertia}|}{|\text{effect of viscosity}|} \\ &= \frac{|\rho(\mathbf{u} \cdot \nabla)\mathbf{u}|}{|\mu \nabla^2 \mathbf{u}|} \\ &\sim \frac{\rho U^2/L}{\mu U/L^2} \\ &\sim \frac{\rho UL}{\mu}. \end{aligned} \tag{9.21}$$

In fig. 9.4, and fig. 9.5 we have two illustrations of viscous and non-viscous regions the first with a moving probe pushing its way through a surface, and the second with a wing set at an angle of attack that generates some turbulence. Both are illustrations of the viscous and inviscid regions for the two flows. Both of

these are characterized by the Reynold's number in some way not really specified in class. One of the points of mentioning this is that when we are in an essentially inviscid region, we can neglect the viscosity ($\mu \nabla^2 \mathbf{u}$) term of the flow.

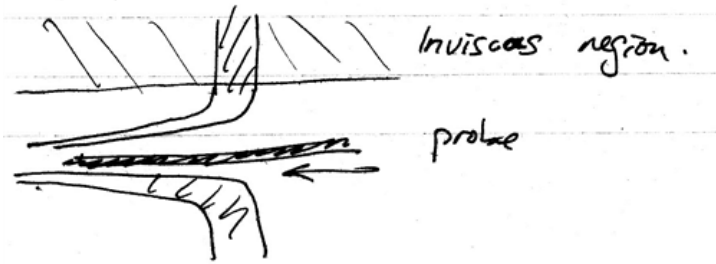

Figure 9.4: Viscous and non-viscous regions.

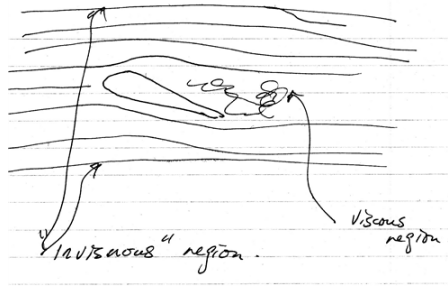

Figure 9.5: Viscous and non-viscous regions.

9.4 SUMMARY.

9.4.1 Non-dimensionality and scaling.

With the variable transformations

$$\mathbf{u} \rightarrow U\mathbf{u}' \quad (9.22)$$

$$p \rightarrow \rho U^2 p' \quad (9.23)$$

$$t \rightarrow \frac{L}{U} t' \quad (9.24)$$

$$\nabla \rightarrow \frac{1}{L} \nabla', \quad (9.25)$$

we can put Navier-Stokes in

$$\frac{\partial \mathbf{u}'}{\partial t'} + (\mathbf{u}' \cdot \nabla') \mathbf{u}' = \nabla' p' + \frac{1}{R} \nabla' \mathbf{u}'. \quad (9.26)$$

Here R is Reynold's number

$$R = \frac{LU}{\nu}. \quad (9.27)$$

A relatively high or low Reynold's number will effect whether viscous or inertial effects dominate

$$R \sim \frac{|\text{effect of inertia}|}{|\text{effect of viscosity}|} \sim \frac{|\rho(\mathbf{u} \cdot \nabla)\mathbf{u}|}{|\mu \nabla^2 \mathbf{u}|}. \quad (9.28)$$

The importance of examining where one of these effects can dominate was clear in the Blassius problem, where doing so allowed for an analytic solution that would not have been possible otherwise.

9.5 PROBLEMS.

Exercise 9.1 Velocity non-dimensionalisation. (2012 ps3)

In fluid convection problems one can make several choices for characteristic velocity scales. Some choices are given below for example:

1. $U_1 = g\alpha d^2 \nabla T / \nu$
2. $U_2 = \nu / d$
3. $U_3 = \sqrt{g\alpha d \nabla T}$
4. $U_4 = \kappa / d,$

where g is the acceleration due to gravity, $\alpha = (\partial V / \partial T) / V$ is the coefficient of volume expansion, d length scale associated with the problem, ∇T is the applied temperature difference, ν is the kinematic viscosity and κ is the thermal diffusivity.

- a. Verify that each of the expressions above have units of velocity.

- b. Water convection at room temperature. For pure liquid, say pure water at room temperature, one has the following estimates in cgs units:

$$\begin{aligned}\alpha &\sim 10^{-4} \\ \kappa &\sim 10^{-3} \\ \nu &\sim 10^{-2}.\end{aligned}\tag{9.29}$$

For a $d \sim 1\text{cm}$ layer depth and a ten degree temperature drop convective velocities have been experimentally measured of about 10^{-2} . With $g \sim 10^{-3}$, calculate the values of U_1 , U_2 , U_3 , and U_4 . Which ones of the characteristic velocities (U_1, U_2, U_3, U_4) do you think are suitable for nondimensionalising the velocity in Navier-Stokes/Energy equation describing the water convection problem?

- c. For mantle convection, we have

$$\begin{aligned}\alpha &\sim 10^{-5} \\ \nu &\sim 10^{21} \\ \kappa &\sim 10^{-2} \\ d &\sim 10^8 \\ \nabla T &\sim 10^3,\end{aligned}\tag{9.30}$$

and the actual convective mantle velocity is 10^{-8} . Which of the characteristic velocities should we use to nondimensionalise Navier-Stokes/Energy equations describing mantle convection?

Answer for Exercise 9.1

Solution Part a. *Verify units.* Let us check each of the velocity expressions in turn.

1. For U_1 : Observing that

$$\left[\frac{\partial \mathbf{u}}{\partial t}\right] = [\nu \nabla^2 \mathbf{u}],\tag{9.31}$$

we must have

$$[\nu] = \frac{1}{[t][\nabla^2]} = \frac{1}{T}L^2.\tag{9.32}$$

We also find

$$[\alpha] = \frac{1}{[V]} \left[\frac{\partial V}{\partial T} \right] = \frac{1}{[K]}, \quad (9.33)$$

so that

$$[U_1] = \frac{L}{T} \frac{1}{K} L^2 K \frac{T}{L^2} = \frac{L}{T}. \quad (9.34)$$

2. For U_2 :

$$[U_2] = \frac{L^2}{T} \frac{1}{L} = \frac{L}{T}. \quad (9.35)$$

3. For U_3 :

$$[U_3] = \sqrt{\frac{L}{T^2} \frac{1}{K} L K} = \frac{L}{T}. \quad (9.36)$$

4. For U_4 : According to [15], thermal diffusivity is defined by

$$\frac{\partial T}{\partial t} = \kappa \nabla^2 T, \quad (9.37)$$

so that

$$[\kappa] = \frac{1}{[t][\nabla^2]} = \frac{L^2}{T}. \quad (9.38)$$

That gives us

$$[U_4] = \frac{L^2}{T} \frac{1}{L} = \frac{L}{T}. \quad (9.39)$$

Solution Part b. *Water convection.* For water at room temperature, we have

$$\begin{aligned} U_1 &\sim 10^{-3} 10^{-4} (1)^2 10^1 \frac{1}{10^{-2}} = 10^{-4} \\ U_2 &\sim 10^{-2} / 1 = 10^{-2} \\ U_3 &\sim \sqrt{10^{-3} 10^{-4} (1) 10^1} = 10^{-3} \\ U_4 &\sim 10^{-3} / 1 = 10^{-3}. \end{aligned} \quad (9.40)$$

Use of $U_2 = v/d$ gives the closest match to the measured characteristic velocity of 10^{-2} .

Solution Part c. Mantle convection. For the mantle convection problem let us compute the characteristic velocities

$$\begin{aligned} U_1 &\sim \frac{10^{-3}10^{-5}10^{16}10^3}{10^{21}} = 10^{-10} \\ U_2 &\sim \frac{10^{21}}{10^8} = 10^{13} \\ U_3 &\sim \sqrt{10^{-3}10^{-5}10^810^3} \sim 10^1 \\ U_4 &\sim \frac{10^{-2}}{10^8} = 10^{-10}. \end{aligned} \tag{9.41}$$

Both U_1 and U_4 come close to the actual convective mantle velocity of 10^{-8} . Use of U_1 to nondimensionalise is probably best, since it has more degrees of freedom, and includes the gravity term that is probably important for such large masses.

Exercise 9.2 **Nondimensionalise N-S equation. (2012 ps3, p2)**

$$\rho \frac{\partial \mathbf{u}}{\partial t} + \rho(\mathbf{u} \cdot \nabla)\mathbf{u} = -\nabla p + \mu \nabla^2 \mathbf{u} + \rho g \hat{\mathbf{z}}, \tag{9.42}$$

where $\hat{\mathbf{z}}$ is the unit vector in the z direction. You may scale:

- velocity with the characteristic velocity U ,
- time with R/U , where R is the characteristic length scale,
- pressure with ρU^2 .

Reynolds number $\text{Re} = RU\rho/\mu$ and Froude number $\text{Fr} = gR/U$.

Answer for Exercise 9.2

Let us start by dividing by $g\rho$, to make all terms (most obviously the $\hat{\mathbf{z}}$ term) dimensionless.

$$\frac{1}{g} \frac{\partial \mathbf{u}}{\partial t} + \frac{1}{g}(\mathbf{u} \cdot \nabla)\mathbf{u} = -\frac{1}{g\rho} \nabla p + \frac{\mu}{g\rho} \nabla^2 \mathbf{u} + \hat{\mathbf{z}}. \tag{9.43}$$

Our suggested replacements are

$$\begin{aligned} \mathbf{u} &= U\mathbf{u}' \\ \frac{\partial}{\partial t} &= \frac{U}{R} \frac{\partial}{\partial t'} \\ p &= \rho U^2 p' \\ \nabla &= \frac{1}{R} \nabla'. \end{aligned} \tag{9.44}$$

Plugging these in we have

$$\frac{U^2}{gR} \frac{\partial \mathbf{u}'}{\partial t'} + \frac{U^2}{gR} (\mathbf{u}' \cdot \nabla') \mathbf{u}' = -\frac{\rho U^2}{g\rho R} \nabla' p' + \frac{\mu U}{g\rho R^2} \nabla'^2 \mathbf{u}' + \hat{\mathbf{z}}. \tag{9.45}$$

Making a $\text{Fr} = gR/U$ replacement, using the Froude number, we have

$$\frac{U}{\text{Fr}} \frac{\partial \mathbf{u}'}{\partial t'} + \frac{U}{\text{Fr}} (\mathbf{u}' \cdot \nabla') \mathbf{u}' = -\frac{U}{\text{Fr}} \nabla' p' + \frac{\mu}{\text{Fr}\rho R} \nabla'^2 \mathbf{u}' + \hat{\mathbf{z}}. \tag{9.46}$$

Scaling by Fr/U we tidy things up a bit, and also allow for insertion of the Reynold's number

$$\frac{\partial \mathbf{u}'}{\partial t'} + (\mathbf{u}' \cdot \nabla') \mathbf{u}' = -\nabla' p' + \frac{1}{\text{Re}} \nabla'^2 \mathbf{u}' + \frac{\text{Fr}}{U} \hat{\mathbf{z}}. \tag{9.47}$$

Observe that the dimensions of Froude's number is that of velocity

$$[\text{Fr}] = [g]T = \frac{L}{T}, \tag{9.48}$$

so that the end result is dimensionless as desired. We also see that Froude's number, characterizes the significance of the body force for fluid flow at the characteristic velocity. This is consistent with [27] where it was stated that the Froude number is used to determine the resistance of a partially submerged object moving through water, and permits the comparison of objects of different sizes (complete with pictures of canoes of various sizes that Froude built for such study).

BOUNDARY LAYERS.

10.1 TIME DEPENDENT FLOW.

Suppose we have an obstacle to fluid flow, as in fig. 10.1 we have a

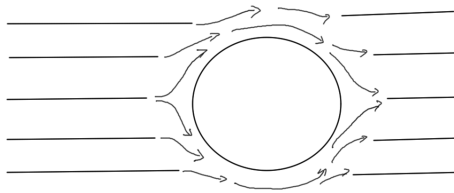

Figure 10.1: Flow lines around circular obstacle.

couple conditions on fluid flow.

1. No fluid can cross the solid boundary
2. Due to viscosity the tangential velocity of the fluid should match the velocity of the solid boundary.

In study of this type of flow, we can consider the flow separated into two portions, one is a flow that is largely viscous, and the other that is largely inertial. This is depicted in fig. 10.2

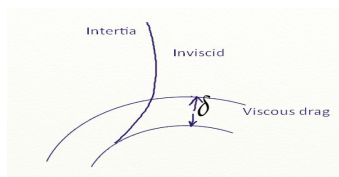

Figure 10.2: Viscous and inviscid regions in boundary layer flow.

We call the study of these two regions boundary layer flow.

10.2 UNSTEADY RECTILINEAR FLOW.

Given

$$\mathbf{u} = u(x, y, z, t)\hat{\mathbf{x}}, \quad (10.1)$$

the continuity equation (incompressibility assumption) is

$$\frac{\partial u}{\partial x} + \frac{\partial v}{\partial y} + \frac{\partial w}{\partial z} = 0. \quad (10.2)$$

Our non-linear term of Navier-Stokes is then killed

$$u \frac{\partial u}{\partial x} = 0 \quad (10.3)$$

so that Navier Stokes takes the form

$$\rho \frac{\partial u}{\partial t} = -\frac{\partial p}{\partial x} + \mu \left(\frac{\partial^2 u}{\partial y^2} + \frac{\partial^2 u}{\partial z^2} \right), \quad (10.4a)$$

$$0 = -\frac{\partial p}{\partial y}, \quad (10.4b)$$

$$0 = -\frac{\partial p}{\partial z}. \quad (10.4c)$$

Taking the x partial of eq. (10.4a), we have

$$\rho \frac{\partial}{\partial t} \frac{\partial u}{\partial x} = -\frac{\partial^2 p}{\partial x^2} + \mu \left(\frac{\partial^2}{\partial y^2} \frac{\partial u}{\partial x} + \frac{\partial^2}{\partial z^2} \frac{\partial u}{\partial x} \right). \quad (10.5)$$

Since we also have zero partials in the y and z directions from eq. (10.4b), and eq. (10.4c), we must then have

$$\frac{d^2 p}{dx^2} = 0. \quad (10.6)$$

So, after integrating we find for the pressure

$$p(x, t) = p_0(t) - Gx, \quad (10.7)$$

where

$$G = -\frac{dp}{dx}. \quad (10.8)$$

In general G is a function of t , but constant in space. Given this, we have for our Navier-Stokes equation

$$\rho \frac{\partial u}{\partial t} = G(t) + \mu \left(\frac{\partial^2 u}{\partial y^2} + \frac{\partial^2 u}{\partial z^2} \right). \quad (10.9)$$

Example 10.1: Impulsively started flow.

Reading: §2 from [2]

Let us consider a flow driven by a moving boundary. We have two ways that we can look at such a flow, the first of which is with the fluid fixed and the boundary moving and the second is with the fluid moving and the boundary fixed. This are depicted respectively in fig. 10.3.

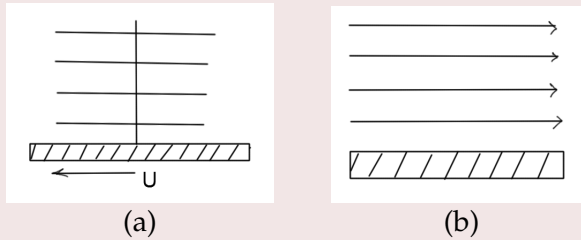

Figure 10.3: Lagrangian and Eulerian views.

These two possible viewpoints can be called the Eulerian and the Lagrangian views where

- Lagrangian: the observer is moving with the fluid.
- Eulerian: the observer is fixed in space, watching the fluid.

With a flow of the form

$$\mathbf{u} = u(y, t)\hat{\mathbf{x}}, \quad (10.10)$$

the Navier-Stokes equation is

$$\boxed{\frac{\partial u}{\partial t} = \nu \frac{\partial^2 u}{\partial y^2}}. \quad (10.11)$$

Our boundary value constraints are

$$u(0, t) = \begin{cases} 0 & \text{for } t < 0 \\ U & \text{for } t \geq 0, \end{cases} \quad (10.12)$$

and $u \rightarrow 0$ as $y \rightarrow \infty$.

If we make a transformation to dimensionless arguments

$$u \rightarrow U, \quad (10.13)$$

so that

$$\frac{u}{U} \rightarrow \text{dimensionless.} \quad (10.14)$$

Then we require of the parameters

$$y, \nu, t \rightarrow \frac{y}{\sqrt{\nu t}}, \quad (10.15)$$

so that we have a characteristic length scale of the form

$$\delta \rightarrow \sqrt{\nu t}. \quad (10.16)$$

We can find an approximate solution

$$\frac{U}{t} \approx \frac{\nu U}{\delta^2}. \quad (10.17)$$

We can introduce a similarity variable (often hard to find), of the form

$$\eta = \frac{y}{2\sqrt{\nu t}}. \quad (10.18)$$

Let us use our similarity variable and see what happens. With

$$u = Uf(\eta), \quad (10.19)$$

we find

$$\begin{aligned} \frac{\partial u}{\partial y} &= \frac{\partial u}{\partial \eta} \frac{\partial \eta}{\partial y} \\ &= Uf' \frac{1}{2\sqrt{\nu t}}, \end{aligned} \quad (10.20)$$

where

$$f' = \frac{\partial f}{\partial \eta}. \quad (10.21)$$

We then find

$$\frac{\partial^2 u}{\partial y^2} = U f'' \frac{1}{4vt}, \quad (10.22)$$

and

$$\begin{aligned} \frac{\partial u}{\partial t} &= \frac{\partial u}{\partial \eta} \frac{\partial \eta}{\partial t} \\ &= \frac{\partial u}{\partial \eta} \frac{\partial}{\partial t} \left(\frac{y}{2\sqrt{vt}} \right) \\ &= -\frac{1}{2} \frac{\partial u}{\partial \eta} \left(\frac{y}{2\sqrt{vt}^{3/2}} \right) \\ &= -U f' \frac{\eta}{2t}. \end{aligned} \quad (10.23)$$

Putting these all together we have

$$-U f' \frac{\eta}{2t} = U f'' \frac{1}{4vt}, \quad (10.24)$$

or

$$f'' + 2\eta f' = 0. \quad (10.25)$$

With $g = f'$, we have

$$\int \frac{dg}{g} = \int -2\eta y. \quad (10.26)$$

With solution

$$\ln(f') = -\eta^2 + \ln C, \quad (10.27)$$

or

$$f' = C e^{-\eta^2}. \quad (10.28)$$

Integrating once more, and writing the integral in terms of the error function

$$\operatorname{erf}(\eta) = \frac{2}{\sqrt{\pi}} \int_0^\eta e^{-s^2} ds, \quad (10.29)$$

We find

$$f(\eta) = A \operatorname{erf}(\eta) + B. \quad (10.30)$$

From our boundary value condition at the origin we have

$$u(0, t) = Uf(0) = U, \quad (10.31)$$

so that

$$U(A \operatorname{erf}(0) + B) = U. \quad (10.32)$$

Since $\operatorname{erf}(0) = 0$, we must have $B = 1$. For our boundary value constraint far from the impulse, we have

$$u(\infty, t) = U(A \operatorname{erf}(\infty) + 1) = 0, \quad (10.33)$$

but since $\operatorname{erf}(\infty) = 1$, we must have $A = -1$. Our solution is then found to be

$$u(y, t) = U(1 - \operatorname{erf}(\eta)). \quad (10.34)$$

where (again)

$$\eta = \frac{y}{2\sqrt{vt}}. \quad (10.35)$$

Explicitly, this is

$$u(y, t) = U_0 \left(1 - \operatorname{erf} \left(\frac{y}{2\sqrt{vt}} \right) \right). \quad (10.36)$$

If we look at the thickness of the boundary layer for different viscosities, sampled at different times we may end up with curves as in fig. 10.4

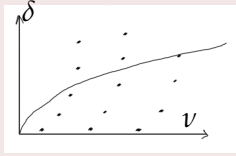

Figure 10.4: Plots of separation thickness for different viscosities.

However, it turns out that for any fluids, regardless of the viscosities, the thickness of the boundary layers generally vary as a linear function of \sqrt{vt} so if δ is plotted against that as in fig. 10.5 we see a linear relationship.

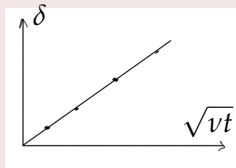

Figure 10.5: Linear relation between separation thickness and \sqrt{vt} .

10.3 REVIEW. IMPULSIVELY STARTED FLOW.

Were looking at flow driven by an impulse, a sudden motion of the plate, as in fig. 10.6 where the fluid at the origin is pushed so

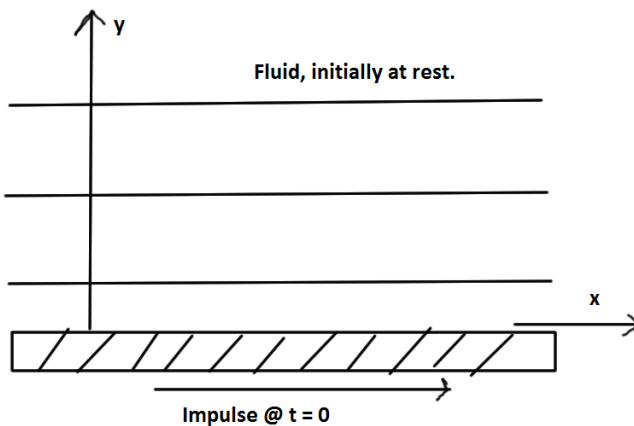

Figure 10.6: Impulsively driven time dependent fluid flow.

that it is given the velocity

$$u(0, t) = \begin{cases} 0 & \text{for } t < 0 \\ U(t) & \text{for } t \geq 0, \end{cases} \quad (10.37)$$

where $U \rightarrow 0$ as $y \rightarrow \infty$.

Navier-Stokes takes the form

$$\frac{\partial u}{\partial t} = \nu \frac{\partial^2 u}{\partial y^2}. \quad (10.38)$$

With a similarity variable

$$\eta = \frac{y}{2\sqrt{\nu t}}, \quad (10.39)$$

and

$$u = Uf(\eta), \quad (10.40)$$

we found that we needed to solve

$$f'' + 2\eta f' = 0, \quad (10.41)$$

where

$$f' = \frac{df}{d\eta}, \quad (10.42)$$

with solution

$$u(y, t) = U(1 - \operatorname{erf}(\eta)). \quad (10.43)$$

Here, we have used the error function

$$\operatorname{erf}(\eta) = \frac{2}{\sqrt{\pi}} \int_0^\eta e^{-s^2} ds, \quad (10.44)$$

as plotted in fig. 10.7

10.4 BOUNDARY LAYERS.

Let us look at spacetime points which are constant in η

$$\frac{y_1}{2\sqrt{\nu t_1}} = \frac{y_2}{2\sqrt{\nu t_2}}, \quad (10.45)$$

so that the speed at (y_1, t_1) equals the speed at (y_2, t_2) . This is illustrated in fig. 10.8

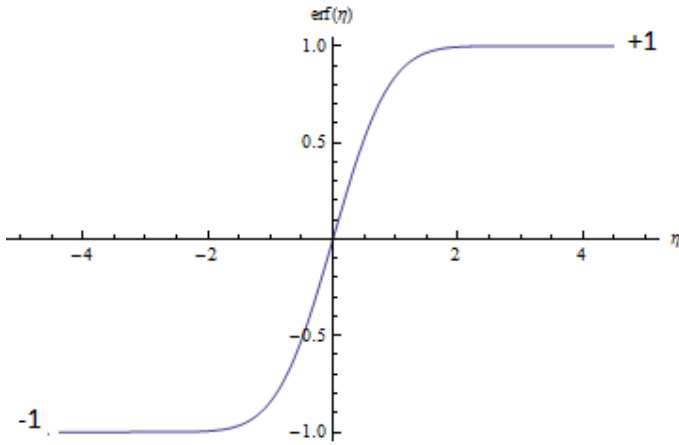

Figure 10.7: Error function.

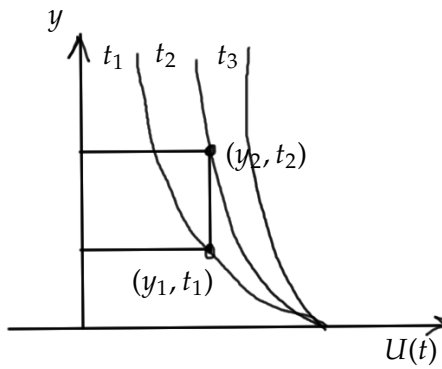

Figure 10.8: Velocity profiles at different times.

10.5 UNIVERSAL BEHAVIOR.

Looking at a plot with different viscosities for position vs time scaled as \sqrt{vt} as in fig. 10.9 we see a sort of universal behavior. Characterizing this we introduce the concept of boundary layer

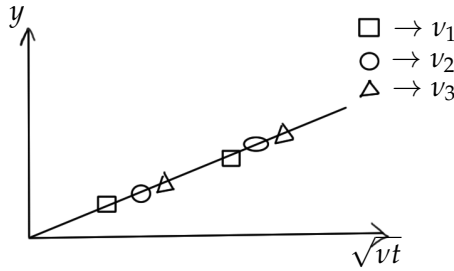

Figure 10.9: Universal behavior.

thickness

Definition 10.1: Boundary layer thickness

The length scale over which is dominant. This is the viscous length scale.

This is similar to what we have in the heat equation

$$\frac{\partial T}{\partial t} = \kappa \frac{\partial^2 T}{\partial y^2}, \quad (10.46)$$

where the time scale for the diffusion can be expressed as

$$[\kappa_t] = \frac{d^2}{\kappa}. \quad (10.47)$$

We could consider a scenario such as a heated plate in a cavity of height δ as in fig. 10.10 with a temperature T on the bottom plate. We can ask how fast the heat propagates through the medium.

Example 10.2: Oscillating plate.

Consider an oscillating plate, driving the motion of the fluid, as in fig. 10.11

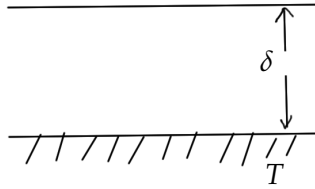

Figure 10.10: Characteristic distances in heat flow problems.

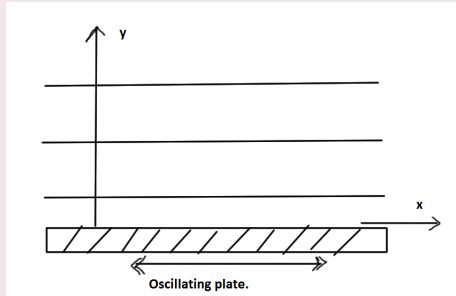

Figure 10.11: Time dependent fluid motion due to oscillating plate.

$$U(t) = U_0 \cos \Omega t = \operatorname{Re} \left(U_0 e^{i\Omega t} \right). \quad (10.48)$$

(we are thinking here about the always oscillating case, and not an impulsive plate motion).

We write

$$u(y, t) = \operatorname{Re} \left(f(y) e^{i\Omega t} \right), \quad (10.49)$$

with substitution into

$$\frac{\partial u}{\partial t} = \nu \frac{\partial^2 u}{\partial y^2}, \quad (10.50)$$

we have

$$i\Omega f(y) e^{i\Omega t} = \nu f'' e^{i\Omega t}, \quad (10.51)$$

or

$$i\Omega f(y) = \nu f''. \quad (10.52)$$

This is an equation of the form

$$f'' = m^2 f, \quad (10.53)$$

where

$$m^2 = \frac{i\Omega}{\nu}. \quad (10.54)$$

or

$$m = \sqrt{\frac{i\Omega}{\nu}} = \lambda(1+i), \quad (10.55)$$

where

$$\lambda = \sqrt{\frac{\Omega}{2\nu}}. \quad (10.56)$$

check:

$$\begin{aligned} m^2 &= \frac{\Omega}{2\nu}(i+1)^2 \\ &= \frac{\Omega}{2\nu}(i^2 + 1 + 2i) \\ &= \frac{\Omega}{\nu}i. \end{aligned} \quad (10.57)$$

Considering the boundary value constraints we have

$$f(y) = Ae^{\lambda(1+i)y} + Be^{-\lambda(1+i)y}. \quad (10.58)$$

Since $u(\infty, t) \rightarrow 0$ we must have

$$f(\infty) = 0, \quad (10.59)$$

so we must kill off the exponentially increasing (albeit also oscillating) term by setting $A = 0$. Also, since

$$u(0, t) = U(t), \quad (10.60)$$

we must have

$$f(0) = U_0, \quad (10.61)$$

or

$$B = U_0, \quad (10.62)$$

so

$$f(y) = U_0 e^{-\lambda(1+i)y}, \quad (10.63)$$

and

$$u(y, t) = \text{Re} \left(U_0 e^{-\lambda y} e^{-i(\lambda y - \Omega t)} \right), \quad (10.64)$$

or

$$u(y, t) = U_0 e^{-\lambda y} \cos(-i(\lambda y - \Omega t)). \quad (10.65)$$

This is a damped transverse wave function

$$u(y, t) = f(y - ct), \quad (10.66)$$

where

$$c = \frac{\Omega}{\lambda}, \quad (10.67)$$

is the wave speed.

Since we have an exponential damping here, the flow of fluid will essentially be confined to a boundary layer, where after distance $y = n/\lambda$, the oscillation falls off as

$$\frac{1}{e^n}. \quad (10.68)$$

We can find a nice illustration of such a flow in [16].

10.6 FLUID FLOW OVER A SOLID BODY.

10.6.1 *Scaling arguments.*

We have been talking about impulsively started flow and the Stokes boundary problem.

We will now move on to a similar problem, that of fluid flow over a solid body.

Consider fig. 10.12, where we have an illustration of flow over a solid object with a boundary layer of thickness δ . We have a couple

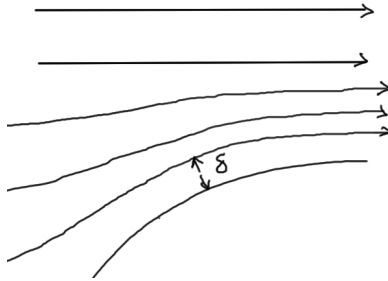

Figure 10.12: Flow over a solid object with boundary layer.

scales to consider.

1. Velocity scale U ,
2. length scale in the y direction δ ,
3. length scale in the x direction L ,

where

$$L \gg \delta. \quad (10.69)$$

As always, we start with the Navier-Stokes equation, restricting ourselves to the steady state $\partial \mathbf{u} / \partial t = 0$ case. In coordinates, for incompressible flows, we have our usual x momentum, y momentum, and continuity equations

$$u \frac{\partial u}{\partial x} + v \frac{\partial u}{\partial y} = -\frac{1}{\rho} \frac{\partial p}{\partial x} + \nu \left(\frac{\partial^2 u}{\partial x^2} + \frac{\partial^2 u}{\partial y^2} \right), \quad (10.70a)$$

$$u \frac{\partial v}{\partial x} + v \frac{\partial v}{\partial y} = -\frac{1}{\rho} \frac{\partial p}{\partial y} + \nu \left(\frac{\partial^2 v}{\partial x^2} + \frac{\partial^2 v}{\partial y^2} \right), \quad (10.70b)$$

$$\frac{\partial u}{\partial x} + \frac{\partial v}{\partial y} = 0. \quad (10.70c)$$

Let us look at the scaling of these equations, starting with the continuity equation eq. (10.70c). This is roughly

$$\begin{aligned}\frac{\partial u}{\partial x} &\sim \frac{U}{L} \\ \frac{\partial v}{\partial y} &\sim \frac{v}{\delta}.\end{aligned}\tag{10.71}$$

We require that these have to be of the same order of magnitude. If these are of the same scale we have

$$\frac{U}{L} \sim \frac{v}{\delta'}\tag{10.72}$$

so that

$$v \sim \frac{U\delta}{L},\tag{10.73}$$

or

$$v \ll U.\tag{10.74}$$

Looking at the viscous terms

$$\begin{aligned}v \frac{\partial^2 u}{\partial x^2} &\sim \frac{vU}{L^2} \\ v \frac{\partial^2 u}{\partial y^2} &\sim \frac{vU}{\delta^2},\end{aligned}\tag{10.75}$$

or

$$v \frac{\partial^2 u}{\partial y^2} \gg v \frac{\partial^2 u}{\partial x^2}.\tag{10.76}$$

So we can neglect the x component of the Laplacian in our x momentum equation eq. (10.70a).

How about the inertial terms

$$\begin{aligned}u \frac{\partial u}{\partial x} &\sim \frac{U^2}{L} \\ v \frac{\partial u}{\partial y} &\sim \frac{\delta U U}{L \delta} \sim \frac{U^2}{L}.\end{aligned}\tag{10.77}$$

Since these are of the same order (in the boundary regions) we cannot neglect either. We also cannot neglect the pressure gradient, since this is what induces the flow.

For the y momentum equation we have

$$\begin{aligned} \nu \frac{\partial^2 v}{\partial x^2} &\sim \nu \frac{\delta U}{L} \frac{1}{L^2} \sim \nu \frac{\delta U}{L^3} \ll \frac{\nu U}{\delta^2} \\ \nu \frac{\partial^2 v}{\partial y^2} &\sim \nu \frac{\delta U}{L} \frac{1}{\delta^2} \sim \nu \frac{U}{\delta L} \ll \frac{\nu U}{\delta^2}. \end{aligned} \quad (10.78)$$

We can neglect all the Laplacian terms in the y momentum equation.
 unnumberedSubsectionQuestion: Why compare the magnitude of the viscous terms for the y momentum to the magnitude of the same terms in the x momentum equation, and not to the LHS of the y momentum equation.
 unnumberedSubsectionAnswer: That is a valid point, but our equations are coupled, and contributions from one feed into the other.

We are not done yet. For the inertial terms in the y momentum equation we have

$$\begin{aligned} u \frac{\partial v}{\partial x} &\sim \frac{\delta U^2}{L^2} \\ v \frac{\partial v}{\partial y} &\sim \frac{\delta U}{L} \frac{\delta U}{L} \frac{1}{\delta} \sim \frac{\delta U^2}{L^2}. \end{aligned} \quad (10.79)$$

Note that

$$\frac{\delta U^2}{L^2} = \frac{\delta}{L} \left(\frac{U^2}{L} \right) \ll \frac{U^2}{L}. \quad (10.80)$$

We see that both of the y momentum inertial terms can be neglected in comparison to the x momentum equations.

Putting all of this together, our equations of motion for the boundary flow are now reduced to

$$u \frac{\partial u}{\partial x} + v \frac{\partial u}{\partial y} = -\frac{1}{\rho} \frac{\partial p}{\partial x} + \nu \frac{\partial^2 u}{\partial y^2}, \quad (10.81a)$$

$$\frac{\partial p}{\partial y} = 0, \quad (10.81b)$$

$$\frac{\partial u}{\partial x} + \frac{\partial v}{\partial y} = 0. \quad (10.81c)$$

Utilizing Bernoulli's theorem eq. (7.7), we can deal with the pressure term, the magnitude of which is

$$\begin{aligned} -\frac{\partial}{\partial x} \left(\frac{p}{\rho} \right) &\sim \frac{\partial}{\partial x} \left(\frac{1}{2} u^2 \right) \\ &\sim \frac{2}{2} u \frac{\partial u}{\partial x} \\ &\sim U \frac{dU}{dx}, \end{aligned} \quad (10.82)$$

and our equations of motion are finally reduced to

$$u \frac{\partial u}{\partial x} + v \frac{\partial u}{\partial y} = U \frac{dU}{dx} + \nu \frac{\partial^2 u}{\partial y^2}, \quad (10.83a)$$

$$\frac{\partial p}{\partial y} = 0, \quad (10.83b)$$

$$\frac{\partial u}{\partial x} + \frac{\partial v}{\partial y} = 0. \quad (10.83c)$$

Example 10.3: Fluid flow over a flat plate (Blasius problem).

In the boundary layer we found

1. Continuity equation

$$\frac{\partial u}{\partial x} + \frac{\partial v}{\partial y} = 0. \quad (10.84)$$

2. x momentum equation

$$u \frac{\partial u}{\partial x} + v \frac{\partial u}{\partial y} = -\frac{1}{\rho} \frac{\partial p}{\partial x} + \nu \frac{\partial^2 u}{\partial y^2}. \quad (10.85)$$

3. y momentum equation

$$\frac{\partial p}{\partial y} = 0. \quad (10.86)$$

In the inviscid region p is a constant in y

$$\frac{\partial p}{\partial y} = 0. \tag{10.87}$$

This will be approximately true in the boundary layer too as illustrated in fig. 10.13

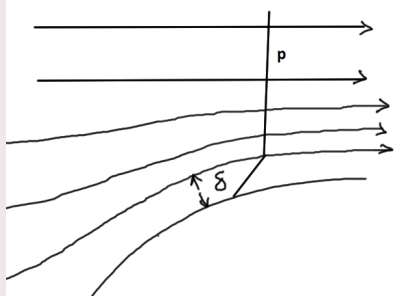

Figure 10.13: Illustrating the boundary layer thickness and associated pressure variation.

Starting with

$$\frac{\partial \mathbf{u}}{\partial t} + (\mathbf{u} \cdot \nabla) \mathbf{u} = -\nabla \left(\frac{p}{\rho} + \chi \right) + \nu \nabla^2 \mathbf{u}, \tag{10.88}$$

we were able to show that inviscid irrotational incompressible flows are governed by Bernoulli’s equation

$$\frac{p}{\rho} + \chi + \frac{1}{2} \mathbf{u}^2 = \text{constant}. \tag{10.89}$$

In the absence of body forces (or constant potentials), we have

$$-\frac{\partial p}{\partial x} = \frac{\partial}{\partial x} \left(\frac{1}{2} \mathbf{u}^2 \right) \sim U \frac{\partial U}{\partial x}, \tag{10.90}$$

so that our boundary layer equations are

$$u \frac{\partial u}{\partial x} + \nu \frac{\partial u}{\partial y} = U \frac{dU}{dx} + \nu \frac{\partial^2 u}{\partial y^2}, \tag{10.91a}$$

$$\frac{\partial p}{\partial y} = 0, \quad (10.91b)$$

$$\frac{\partial u}{\partial x} + \frac{\partial v}{\partial y} = 0. \quad (10.91c)$$

With boundary conditions

$$U(x, 0) = 0$$

$$U(x, \infty) = U(x) \quad (10.92)$$

$$V(x, 0) = 0.$$

Define a similarity variable η

$$\eta \sim \frac{y}{\sqrt{vt}}. \quad (10.93)$$

Suppose we want

$$\eta \sim f(y, x). \quad (10.94)$$

Since we have

$$x \sim Ut, \quad (10.95)$$

or

$$t \sim \frac{x}{U}, \quad (10.96)$$

we can make the transformation

$$\eta = \frac{y}{\sqrt{2\frac{vx}{U}}}. \quad (10.97)$$

We can introduce stream functions

$$u = \frac{\partial \psi}{\partial y} \quad (10.98)$$

$$v = -\frac{\partial \psi}{\partial x}.$$

We can check that this satisfies the continuity equation since we have

$$\begin{aligned}\frac{\partial u}{\partial x} + \frac{\partial v}{\partial y} &= \frac{\partial^2 \psi}{\partial x \partial y} - \frac{\partial^2 \psi}{\partial y \partial x} \\ &= 0.\end{aligned}\tag{10.99}$$

Now introduce a similarity variable

$$f(\eta) = \frac{\psi}{\delta U_0} = \frac{\psi}{\sqrt{2\nu x U_0}}.\tag{10.100}$$

Note that we have also suddenly assumed that $U = U_0$ (a constant, which will also kill the U' term in the N-S equation). This is not really justified by anything we have done so far, but asking about this in class, it was stated that this is a restriction for this formulation of the Blasius problem.

Also note that this last step requires:

$$\delta = \sqrt{2\nu x / U_0}.\tag{10.101}$$

This at least makes sense dimensionally since we have

$$[\sqrt{\nu x / U}] = \sqrt{(L^2/T)(L)(T/L)} = L,\tag{10.102}$$

but where did this definition of δ come from?

In [22] it is mentioned that this is a result of the scaling argument. We did have some scaling arguments that included δ in the expressions from last lecture, one of which was eq. (10.90)

$$\delta \sim \frac{\nu L}{U},\tag{10.103}$$

but that does not obviously give us eq. (10.101)?

Ah. We argued that

$$\nu \frac{\partial u}{\partial y} \sim \frac{U^2}{L},\tag{10.104}$$

and that the larger of the viscous terms was

$$\nu \frac{\partial^2 u}{\partial y^2} \sim \frac{\nu U}{\delta^2}. \quad (10.105)$$

If we require that these are the same order of magnitude, as argued in §8.3 of [2], then we find eq. (10.103).

Regardless, given this change of variables, we can apparently compute

$$f''' + f f'' = 0. \quad (10.106)$$

Our boundary conditions are

$$\begin{aligned} f = f' = 0 & \quad \eta = 0 \\ f' = 1 & \quad \eta = \infty. \end{aligned} \quad (10.107)$$

Attempting to derive eq. (10.106) using the definitions above gets a bit messy. It is messy enough that I mistakenly thought that we could not possibly arrive at a differential equation that has a plain old (non-derivative) f in it as in eq. (10.106) above. The algebra involved in taking the derivatives got the better of me. This derivation is treated a different way in [2]. For the purpose of completeness (and because that derivation also leaves out some details), let's do this from start to finish with all the gory details, but following the outline provided in the text.

Instead of pre-determining the form of the similarity variable exactly, we can state it in terms of an unknown and to be determined function of position writing

$$\eta = \frac{y}{g(x)}. \quad (10.108)$$

We still introduce stream our stream functions eq. (10.98), but require that our horizontal velocity component is only a function of our similarity variable

$$u = U h(\eta), \quad (10.109)$$

where $h(\eta)$ is to be determined, and is scaled by our characteristic velocity U . Observe that, as above, we are assuming that $U(x) = U$, a constant (which also kills off the UU' term in the Navier-Stokes equation.) Given this form of u , we note that

$$u(\eta) = \frac{\partial \psi}{\partial y} = \frac{\partial \psi}{\partial \eta} \frac{\partial \eta}{\partial y} = \frac{1}{g(x)} \frac{\partial \psi}{\partial \eta}, \quad (10.110)$$

so that

$$\psi = Ug(x) \int_0^\eta h(\eta') d\eta' + k(x). \quad (10.111)$$

It is argued in the text that we also want ψ to be a streamline, so that $\psi(\eta = 0) = 0$ implying that $k(x) = 0$. I do not honestly follow the rationale for that, but it is certainly convenient to set $k(x) = 0$, so let's do so and see where things go. With

$$f(\eta) = \int_0^\eta h(\eta') d\eta'. \quad (10.112)$$

Observe that $f(0)$ is necessarily zero with this definition. We can now write

$$\psi(\eta, x) = Ug(x)f(\eta). \quad (10.113)$$

This is like what we had in class, with the exception that instead of a constant relating ψ and $f(\eta)$ we also have a function of x . That is exactly what we need so that we can end up with both f and derivatives of f in our Navier-Stokes equation.

Now let us do the mechanical bits, computing all the derivatives. We can compute v to start with

$$\begin{aligned}
 v &= -\frac{\partial \psi}{\partial x} \\
 &= -U \frac{\partial}{\partial x} (g(x)f(\eta)) \\
 &= -U \left(g'f + gf' \frac{\partial \eta}{\partial x} \right) \\
 &= -U \left(g'f - gf' \frac{yg'}{g^2} \right) && (10.114) \\
 &= -U \left(g'f - f' \frac{yg'}{g} \right) \\
 &= -U (g'f - f'g'\eta) \\
 &= Ug' (f'\eta - f).
 \end{aligned}$$

We had initially $u = Uh(\eta)$, but $f'(\eta) = h(\eta)$, so we have now got both u and v specified in terms of f and g and their derivatives

$$\begin{aligned}
 u &= Uf' \\
 v &= Ug' (f'\eta - f). && (10.115)
 \end{aligned}$$

We have got a bunch of the u derivatives that we have to compute

$$\begin{aligned}
 \frac{\partial u}{\partial x} &= U \frac{\partial f'}{\partial x} \\
 &= U \frac{\partial f'}{\partial \eta} \frac{\partial \eta}{\partial x} \\
 &= -Uf'' \frac{yg'}{g^2} \\
 &= -Uf'' \eta \frac{g'}{g}, && (10.116)
 \end{aligned}$$

and

$$\begin{aligned}\frac{\partial u}{\partial y} &= U \frac{\partial f'}{\partial y} \\ &= U f'' \frac{\partial \eta}{\partial y} \\ &= U f'' \frac{1}{g},\end{aligned}\tag{10.117}$$

and

$$\begin{aligned}\frac{\partial^2 u}{\partial y^2} &= U \frac{1}{g} \frac{\partial f''}{\partial y} \\ &= U \frac{1}{g} f''' \frac{\partial \eta}{\partial y} \\ &= U \frac{1}{g^2} f'''.\end{aligned}\tag{10.118}$$

Our x component of Navier-Stokes now takes the form

$$\begin{aligned}0 &= u \frac{\partial u}{\partial x} + v \frac{\partial u}{\partial y} - \nu \frac{\partial^2 u}{\partial y^2} \\ &= U f' \left(-U f'' \eta \frac{g'}{g} \right) + U g' (f' \eta - f) U f'' \frac{1}{g} - \nu U \frac{1}{g^2} f''' \\ &= \frac{U}{g^2} \left(\cancel{-U f' g f'' \eta g'} + \cancel{U g g' f' \eta f''} - U g g' f f'' - \nu f''' \right),\end{aligned}\tag{10.119}$$

or (assuming $g \neq 0$)

$$f''' + \frac{U g g'}{\nu} f f'' = 0.\tag{10.120}$$

Now, if we wish $U g g' / \nu = 1$ (to make this equation as easy to solve as possible), we can integrate to find the required form of $g(x)$. This gives

$$\frac{U g^2}{2\nu} = x + C.\tag{10.121}$$

It is argued that we expect

$$\frac{\partial u}{\partial y} = U f'' \frac{1}{g}, \quad (10.122)$$

to become singular at $x = 0$, so we should set $C = 0$. This leaves us with

$$g(x) = \sqrt{\frac{2x\nu}{U}}, \quad (10.123a)$$

$$\eta = \frac{y}{\sqrt{\frac{2x\nu}{U}}}, \quad (10.123b)$$

$$f''' + f f'' = 0, \quad (10.123c)$$

$$u = U f', \quad (10.123d)$$

$$v = (\eta f' - f) \frac{\nu}{g}, \quad (10.123e)$$

and boundary value conditions

$$f(0) = 0, \quad (10.124a)$$

$$f'(0) = 0, \quad (10.124b)$$

$$f'(\infty) = 1. \quad (10.124c)$$

where eq. (10.124b) follows from $u(0) = 0$ and eq. (10.123d), and eq. (10.124c) follows from the fact that u tends to U .

We can solve this numerically and find solutions that look like fig. 10.14

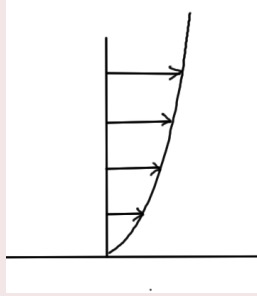

Figure 10.14: Boundary layer solution to flow over plate.

This is the Blasius solution to the problem of fluid flow over a flat plate.

10.7 SUMMARY.

10.7.1 *Impulsive flow.*

We looked at the time dependent unidirectional flow where

$$\mathbf{u} = u(y, t)\hat{\mathbf{x}} \quad (10.125)$$

$$\frac{\partial u}{\partial t} = \nu \frac{\partial^2 u}{\partial y^2} \quad (10.126)$$

$$u(0, t) = \begin{cases} 0 & \text{for } t < 0 \\ U & \text{for } t \geq 0, \end{cases} \quad (10.127)$$

and utilized a similarity variable η with $u = Uf(\eta)$

$$\eta = \frac{y}{2\sqrt{\nu t}}, \quad (10.128)$$

and were able to show that

$$u(y, t) = U_0 \left(1 - \operatorname{erf} \left(\frac{y}{2\sqrt{\nu t}} \right) \right). \quad (10.129)$$

The aim of this appears to be as an illustration that the boundary layer thickness δ grows with $\sqrt{\nu t}$.

10.7.2 *Oscillatory flow.*

Another worked problem in the boundary layer topic was the Stokes boundary layer problem with a driving interface of the form

$$U(t) = U_0 e^{i\Omega t}, \quad (10.130)$$

with an assumed solution of the form

$$u(y, t) = f(y) e^{i\Omega t}, \quad (10.131)$$

we found

$$u(y, t) = U_0 e^{-\lambda y} \cos(-i(\lambda y - \Omega t)), \quad (10.132a)$$

$$\lambda = \sqrt{\frac{\Omega}{2\nu}}. \quad (10.132b)$$

This was a bit more obvious as a boundary layer illustration since we see the exponential drop off with every distance multiple of $\sqrt{\frac{2\nu}{\Omega}}$.

10.7.3 *Blasius problem (boundary layer thickness in flow over plate).*

We examined the scaling off all the terms in the Navier-Stokes equations given a velocity scale U , vertical length scale δ and horizontal length scale L . This, and the application of Bernoulli's theorem allowed us to make construct an approximation for Navier-Stokes in the boundary layer

$$u \frac{\partial u}{\partial x} + v \frac{\partial u}{\partial y} = U \frac{dU}{dx} + \nu \frac{\partial^2 u}{\partial y^2}, \quad (10.133a)$$

$$\frac{\partial p}{\partial y} = 0, \quad (10.133b)$$

$$\frac{\partial u}{\partial x} + \frac{\partial v}{\partial y} = 0. \quad (10.133c)$$

With boundary conditions

$$U(x, 0) = 0 \quad (10.134)$$

$$U(x, \infty) = U(x) = U_0 \quad (10.135)$$

$$V(x, 0) = 0. \quad (10.136)$$

With a similarity variable

$$\eta = \frac{y}{\sqrt{2\nu x/U}} \quad (10.137)$$

and stream functions

$$u = \frac{\partial \psi}{\partial y} \quad (10.138)$$

$$v = -\frac{\partial \psi}{\partial x}, \quad (10.139)$$

and

$$\psi = f(\eta)\sqrt{2\nu x U_0}, \quad (10.140)$$

we were able to show that our velocity dependence was given by the solutions of

$$f''' + ff'' = 0. \quad (10.141)$$

This was done much more clearly in [2] and I worked this problem myself with a hybrid approach (non-dimensionalising as done in class).

10.8 PROBLEMS.

Exercise 10.1 Oscillatory boundary, phase angle. (2012 ps3, p3)

Starting with the solution of the Stokes' boundary layer problem calculate shear stress on the plate $y = 0$. What is the phase difference between the velocity of the plate $U(t) = U_0 \cos \omega t$ and the shear stress on the plate?

Answer for Exercise 10.1

We found in class that the velocity of the fluid was given by

$$u(y, t) = U_0 e^{-\lambda y} \cos(\lambda y - \omega t), \quad (10.142)$$

where

$$\lambda = \sqrt{\frac{\omega}{2\nu}}. \quad (10.143)$$

Calculating our shear stress we find

$$\mu \frac{\partial u}{\partial y} = U_0 \lambda \mu e^{-\lambda y} (-1 - \sin(\lambda y - \omega t)), \quad (10.144)$$

and on the plate ($y = 0$) this is just

$$\mu \left. \frac{\partial u}{\partial y} \right|_{y=0} = U_0 \lambda \mu (-1 + \sin(\omega t)). \quad (10.145)$$

We have got a constant term, plus one that is sinusoidal. Observing that

$$\begin{aligned} \cos x &= \operatorname{Re}(e^{ix}) \\ \sin x &= \operatorname{Re}(-ie^{ix}) = \operatorname{Re}(e^{i(x-\pi/2)}). \end{aligned} \quad (10.146)$$

The phase difference between the non-constant portion of the shear stress at the plate, and the plate velocity $U(t) = U_0 \cos \omega t$ is just $-\pi/2$. The shear stress at the plate lags the driving velocity by 90 degrees.

Exercise 10.2 Spin down of coffee in a bottomless cup.

Here is a variation of a problem outlined in §2 of [2], which looked at the time evolution of fluid with initial rotational motion, after the (cylindrical) rotation driver stops, later describing this as the spin down of a cup of tea. I will work the problem in more detail than in the text, and also make two refinements.

1. I drink coffee and not tea,
2. I stir my coffee in the interior of the cup and not on the outer edge.

Because of the second point I will model my stir stick as a rotating cylinder in the cup and not by somebody spinning the cup itself to stir the tea. This only changes the solution for the steady state part of the problem.

Answer for Exercise 10.2

We will work in cylindrical coordinates following the conventions of fig. 10.15. We will assume a solution that with velocity

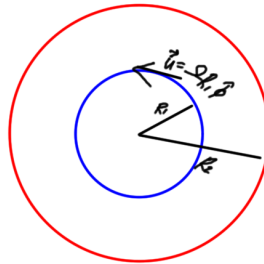

Figure 10.15: Fluid flow in nested cylinders.

azimuthal in direction, and both pressure and velocity that are only radially dependent.

$$\mathbf{u} = u(r)\hat{\phi} \tag{10.147}$$

$$p = p(r). \tag{10.148}$$

Let us first verify that this meets the non-compressible condition that eliminates the $\mu \nabla(\nabla \cdot \mathbf{u})$ term from Navier-Stokes

$$\begin{aligned} \nabla \cdot \mathbf{u} &= \left(\hat{\mathbf{r}}\partial_r + \frac{\hat{\phi}}{r}\partial_\phi + \hat{\mathbf{z}}\partial_z \right) \cdot (u\hat{\phi}) \\ &= \hat{\phi} \cdot \left(\hat{\mathbf{r}}\partial_r u + \frac{\hat{\phi}}{r}\partial_\phi u + \hat{\mathbf{z}}\partial_z u \right) + u \left(\hat{\mathbf{r}} \cdot \partial_r \hat{\phi} + \frac{\hat{\phi}}{r} \cdot \partial_\phi \hat{\phi} + \hat{\mathbf{z}} \cdot \partial_z \hat{\phi} \right) \\ &= \hat{\phi} \cdot \hat{\mathbf{r}}\partial_r u + u \frac{\hat{\phi}}{r} \cdot (-\hat{\mathbf{r}}) \\ &= 0. \end{aligned} \tag{10.149}$$

Good. Now let us express each of the terms of Navier-Stokes in cylindrical form. Our time dependence is

$$\rho \partial_t u(r, t) \hat{\phi} = \rho \hat{\phi} \partial_t u. \quad (10.150)$$

Our inertial term is

$$\begin{aligned} \rho(\mathbf{u} \cdot \nabla) \mathbf{u} &= \frac{\rho u}{r} \partial_\phi (u \hat{\phi}) \\ &= \frac{\rho u^2}{r} (-\hat{\mathbf{r}}). \end{aligned} \quad (10.151)$$

Our pressure term is

$$-\nabla p = -\hat{\mathbf{r}} \partial_r p, \quad (10.152)$$

and our Laplacian term is

$$\begin{aligned} \mu \nabla^2 \mathbf{u} &= \mu \left(\frac{1}{r} \partial_r (r \partial_r) + \frac{1}{r^2} \partial_{\phi\phi} + \partial_{zz} \right) u(r) \hat{\phi} \\ &= \mu \left(\frac{\hat{\phi}}{r} \partial_r (r \partial_r u) + \frac{-\hat{\mathbf{r}} u}{r^2} \right). \end{aligned} \quad (10.153)$$

Putting things together, we find that Navier-Stokes takes the form

$$\rho \hat{\phi} \partial_t u + \frac{\rho u^2}{r} (-\hat{\mathbf{r}}) = -\hat{\mathbf{r}} \partial_r p + \mu \left(\frac{\hat{\phi}}{r} \partial_r (r \partial_r u) + \frac{-\hat{\phi} u}{r^2} \right), \quad (10.154)$$

which nicely splits into an separate equations for the $\hat{\phi}$ and $\hat{\mathbf{r}}$ directions respectively

$$\frac{1}{\nu} \partial_t u = \frac{1}{r} \partial_r (r \partial_r u) - \frac{u}{r^2}, \quad (10.155a)$$

$$\frac{\rho u^2}{r} = \partial_r p. \quad (10.155b)$$

Before $t = 0$ we seek the steady state, the solution of

$$r \partial_r (r \partial_r u) - u = 0. \quad (10.156)$$

We have seen that

$$u(r) = Ar + \frac{B}{r}, \quad (10.157)$$

is the general solution, and can now fit this to the boundary value constraints. For the interior portion of the cup we have

$$Ar + \frac{B}{r} \Big|_{r=0} = 0 \quad (10.158)$$

so $B = 0$ is required. For the interface of the “stir-stick” (moving fast enough that we can consider it having a cylindrical effect) at $r = R_1$ we have

$$AR_1 = \Omega R_1, \quad (10.159)$$

so the interior portion of our steady state coffee velocity is just

$$\mathbf{u} = \Omega r \hat{\phi}. \quad (10.160)$$

Between the cup edge and the stir-stick we have to solve

$$\begin{aligned} AR_1 + \frac{B}{R_1} &= \Omega R_1 \\ AR_2 + \frac{B}{R_2} &= 0, \end{aligned} \quad (10.161)$$

or

$$\begin{aligned} AR_1^2 + B &= \Omega R_1^2 \\ AR_2^2 + B &= 0. \end{aligned} \quad (10.162)$$

Subtracting we find

$$A = -\frac{\Omega R_1^2}{R_2^2 - R_1^2}, \quad (10.163a)$$

$$B = \frac{\Omega R_1^2 R_2^2}{R_2^2 - R_1^2}, \quad (10.163b)$$

so our steady state coffee flow is

$$\mathbf{u} = \begin{cases} \Omega r \hat{\phi} & r \in [0, R_1] \\ \frac{\Omega R_1^2}{R_2^2 - R_1^2} \left(\frac{R_2^2}{r} - r \right) \hat{\phi} & r \in [R_1, R_2]. \end{cases} \quad (10.164)$$

We can use a separation of variables technique with $u(r, t) = R(r)T(t)$ to find the time evolution

$$\frac{1}{v} \frac{T'}{T} = \frac{1}{R} \left(\frac{1}{r} \partial_r (r \partial_r R) - \frac{R}{r^2} \right) = -\lambda^2, \quad (10.165)$$

which gives us

$$T \propto e^{-\lambda^2 vt}, \quad (10.166)$$

and R specified by

$$0 = r^2 \frac{d^2 R}{dr^2} + r \frac{dR}{dr} + R (r^2 \lambda^2 - 1). \quad (10.167)$$

Checking [1] (9.1.1) we see that this can be put into the standard form of the Bessel equation if we eliminate the λ term. We can do that writing $z = r\lambda$, $\mathcal{R}(z) = R(z/\lambda)$ and noting that $r d/dr = z d/dz$ and $r^2 d^2/dr^2 = z^2 d^2/dz^2$, which gives us

$$0 = z^2 \frac{d^2 \mathcal{R}}{dz^2} + z \frac{d\mathcal{R}}{dz} + \mathcal{R} (z^2 - 1). \quad (10.168)$$

The solutions are

$$\mathcal{R}(z) = J_{\pm 1}(z), Y_{\pm 1}(z). \quad (10.169)$$

From (9.1.5) of the handbook we see that the plus and minus variations are linearly dependent since $J_{-1}(z) = -J_1(z)$ and $Y_{-1}(z) = -Y_1(z)$, and from (9.1.8) that $Y_1(z)$ is infinite at the origin, so our general solution has to be of the form

$$\mathbf{u}(r, t) = \hat{\phi} \sum_{\lambda} c_{\lambda} e^{-\lambda^2 vt} J_1(r\lambda). \quad (10.170)$$

In the text, I see that the transformation $\lambda \rightarrow \lambda/a$ (where a was the radius of the cup) is made so that the Bessel function parameter was dimensionless. We can do that too but write

$$\mathbf{u}(r, t) = \hat{\phi} \sum_{\lambda} c_{\lambda} e^{-\frac{\lambda^2}{R_2^2} vt} J_1 \left(\lambda \frac{r}{R_2} \right). \quad (10.171)$$

Our boundary value constraint is that we require this to match eq. (10.164) at $t = 0$. Let us write $R_2 = R$, $R_1 = aR$, $z = r/R$, so that

we are working in the unit circle with $z \in [0, 1]$. Our boundary problem can now be expressed as

$$\frac{1}{\Omega R} \sum_{\lambda} c_{\lambda} J_1(\lambda z) = \begin{cases} z & z \in [0, a] \\ \frac{1}{\frac{R^2}{a^2} - 1} \left(\frac{1}{z} - z\right) & z \in [a, 1] \end{cases} \quad (10.172)$$

Let us pull the ΩR factor into c_{λ} and state the problem to be solved as

$$\mathbf{u}(r, t) = \Omega R \hat{\phi} \sum_{i=1}^n c_i e^{-\frac{\lambda_i^2}{R^2} vt} J_1\left(\lambda_i \frac{r}{R}\right), \quad (10.173a)$$

$$\sum_{i=1}^n c_i J_1(\lambda_i z) = \phi(z), \quad (10.173b)$$

$$\phi(z) = \begin{cases} z & z \in [0, a] \\ \frac{a^2}{1-a^2} \left(\frac{1}{z} - z\right) & z \in [a, 1] \end{cases}. \quad (10.173c)$$

Looking at §2.7 of [14] it appears the solutions for c_i can be obtained from

$$c_i = \frac{\int_0^1 z \phi(z) J_1(\lambda_i z) dz}{\int_0^1 z J_1^2(\lambda_i z) dz}, \quad (10.174)$$

where λ_i are the zeros of J_1 .

To get a feel for these, a plot of the first few of these fitting functions is shown in fig. 10.16. Using Mathematica ([bottomless-](#)

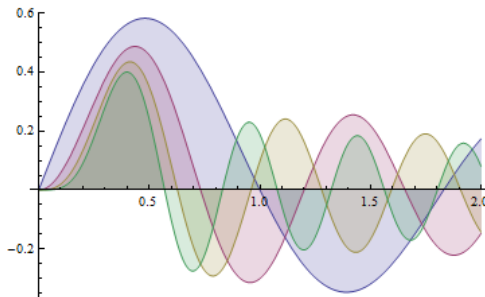

Figure 10.16: Bessel $J_1(\lambda_i z)$ zero crossings.

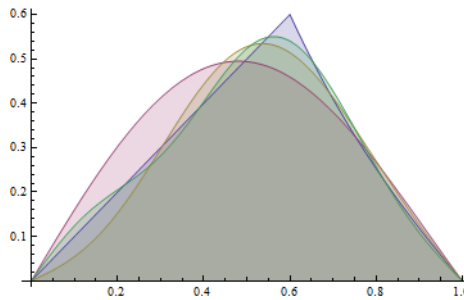

Figure 10.17: Bessel function fitting for the steady state velocity profile for $n = 1, 3, 5$.

[Coffee.cdf](#)), these coefficients were calculated for $a = 0.6$. The $n = 1, 3, 5$ approximations to the fitting function are plotted with a comparison to the steady state velocity profile in fig. 10.17. As indicated in the text, the spin down is way too slow to match reality (this can be seen visually in the worksheet by animating it).

SINGULAR PERTURBATION THEORY.

11.1 MAGNITUDE OF THE VISCOSITY AND INERTIAL TERMS.

In the boundary layer analysis we have assumed that our inertial term and viscous terms were of the same order of magnitude. Lets examine the validity of this assumption

$$u \frac{\partial u}{\partial x} \sim v \frac{\partial^2 u}{\partial y^2}, \quad (11.1)$$

or

$$\frac{U}{L} \sim \frac{\nu U}{\delta^2}, \quad (11.2)$$

or

$$\delta \sim \frac{\nu L}{U}, \quad (11.3)$$

finally

$$\frac{\delta}{L} \sim \frac{\nu}{UL} \sim (\text{Re})^{-1/2}. \quad (11.4)$$

If we have

$$\frac{\delta}{L} \ll 1, \quad (11.5)$$

and

$$\frac{\delta}{L} \ll \frac{1}{\sqrt{\text{Re}}}, \quad (11.6)$$

then

$$\frac{\delta}{L} \ll 1, \quad (11.7)$$

when $\text{Re} \gg 1$. (this is the whole reason that we were able to do the previous analysis). Our EOM is

$$(\mathbf{u} \cdot \nabla) \mathbf{u} = -\frac{\nabla p}{\rho} + \nu \nabla^2 \mathbf{u}, \quad (11.8)$$

with

$$\mathbf{u} \rightarrow U \tag{11.9}$$

$$p \rightarrow U^2 \rho, \tag{11.10}$$

as $x, y \rightarrow L$. Performing a non-dimensionalization we have

$$(\mathbf{u}' \cdot \nabla') \mathbf{u}' = -\nabla' p' + \frac{\nu}{UL} \nabla'^2 \mathbf{u}', \tag{11.11}$$

or

$$(\mathbf{u} \cdot \nabla) \mathbf{u} = -\nabla p + \frac{1}{\text{Re}} \nabla^2 \mathbf{u}. \tag{11.12}$$

To force $\text{Re} \rightarrow \infty$, we can write

$$\frac{1}{\text{Re}} = \epsilon, \tag{11.13}$$

so that as $\epsilon \rightarrow 0$ we have $\text{Re} \rightarrow \infty$.

With a very small number modifying the highest degree partial term, we have a class of differential equations that does not end up converging should we attempt a standard perturbation treatment. An example that is analogous is the differential equation

$$\epsilon \frac{du}{dx} + u = x, \tag{11.14}$$

where $\epsilon \ll 1$ and $u(0) = 1$. The exact solution of this ill conditioned differential equation is

$$u = (1 + \epsilon)e^{-x/\epsilon} + x - \epsilon. \tag{11.15}$$

This is illustrated in fig. 11.1. Study of this class of problems is called *Singular perturbation theory*. When $x \gg \epsilon$ we have approximately

$$u \sim x, \tag{11.16}$$

but when $x \sim O(\epsilon)$, $x/\epsilon \sim O(1)$ we have approximately

$$u \sim e^{-x/\epsilon}. \tag{11.17}$$

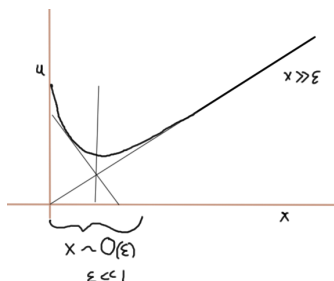

Figure 11.1: Solution to the ill conditioned first order differential equation.

11.2 ASYMPTOTIC SOLUTIONS OF ILL CONDITIONED EQUATIONS.

We will consider two cases, both ones that we can solve exactly

1. With $u(0) = 1$, and letting $\epsilon \rightarrow 0$, we will look at solutions of the ill conditioned LDE

$$\epsilon \frac{du}{dy} + u = y. \quad (11.18)$$

2. With $u(0) = 0$, $u(1) = 2$, and $0 < \epsilon \ll 1$ we will look at the second order ill conditioned LDE

$$\epsilon \frac{d^2u}{dy^2} + \frac{du}{dy} = 1. \quad (11.19)$$

Example 11.1: First order LDE.

We can solve this system exactly. Our homogeneous equation is

$$\epsilon \frac{du}{dy} + u = 0, \quad (11.20)$$

with solution

$$u \propto e^{-y/\epsilon}. \quad (11.21)$$

Looking for a solution of the form

$$u = A(y)e^{-y/\epsilon}, \quad (11.22)$$

we find

$$\epsilon A' e^{-y/\epsilon} = y, \quad (11.23)$$

and integrate to find

$$A(y) = (y - \epsilon)e^{x/\epsilon} + C. \quad (11.24)$$

Application of the boundary value constraints give us

$$u = (1 + \epsilon)e^{-y/\epsilon} + y - \epsilon. \quad (11.25)$$

This is plotted in fig. 11.2

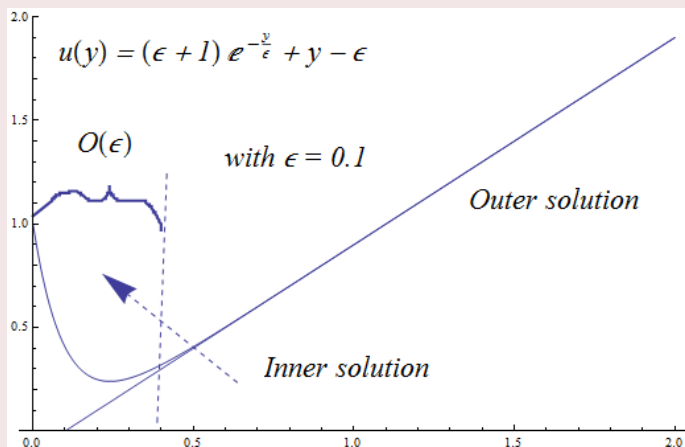

Figure 11.2: Plot of exact solution to simple first order ill conditioned LDE.

We want to consider the limiting case where

$$0 < \epsilon \ll 1, \quad (11.26)$$

and we let $\epsilon \rightarrow 0$. If $y = O(1)$, then we have

$$u \approx 1 \times 0 + y, \quad (11.27)$$

or just

$$u = y. \quad (11.28)$$

However, if $y = O(\epsilon)$ then we have to be more careful constructing an approximation. When y is very small, but ϵ is also of the same order of smallness we have

$$e^{-y/\epsilon} \neq 0. \quad (11.29)$$

If $\epsilon \rightarrow 0$ and $y \rightarrow O(\epsilon)$

$$e^{-y/\epsilon} \rightarrow e^{-\epsilon O(1)/\epsilon} \rightarrow e^{-O(1)}, \quad (11.30)$$

so

$$u \approx e^{-y/\epsilon}. \quad (11.31)$$

For an approximate solution in the inner region, when $y = O(\epsilon)$ define a new scale

$$Y = \frac{y}{\epsilon} \quad (11.32)$$

$$y = O(1), \quad (11.33)$$

so that our LDE takes the form

$$\frac{du}{dY} + u = \epsilon Y. \quad (11.34)$$

When $\epsilon \rightarrow 0$ we have

$$\frac{du}{dY} + u \approx 0. \quad (11.35)$$

We have solution

$$\ln u = -Y + \ln C, \quad (11.36)$$

or

$$u \propto e^{-Y} = e^{-y/\epsilon}. \quad (11.37)$$

Example 11.2: Second order example.

We can also solve this system exactly. We saw above in the first order system that our specific solution was polynomial. While that was found by the method of variation of parameters, it seems obvious in retrospect. Let us start by looking for such a solution, starting with a first order polynomial

$$u = Ay + B. \quad (11.38)$$

Application of our LDE operator on this produces

$$\begin{aligned} A &= 1 \\ B &= 0. \end{aligned} \quad (11.39)$$

Now let us move on to find a solution to the homogeneous equation

$$\epsilon \frac{d^2 u}{dy^2} + \frac{du}{dy} = 0. \quad (11.40)$$

As usual, we look for the characteristic equation by assuming a solution of the form $u = e^{my}$. This gives us

$$\epsilon m^2 + m = (\epsilon m + 1)m = 0, \quad (11.41)$$

with roots

$$m = 0, -1/\epsilon. \quad (11.42)$$

So our homogeneous equation has the form

$$u(y) = Ae^{-y/\epsilon} + B, \quad (11.43)$$

and our full solution is

$$u(y) = Ae^{-y/\epsilon} + B + y, \quad (11.44)$$

with the constants A and B to be determined from our boundary value conditions. We find

$$\begin{aligned} 0 &= u(0) = A + B + 0 \\ 2 &= u(1) = Ae^{-1/\epsilon} + B + 1. \end{aligned} \quad (11.45)$$

We have got $B = -A$ and by subtracting

$$A(e^{-1/\epsilon} - 1) = 1. \quad (11.46)$$

So the exact solution is

$$u = y + \frac{e^{-y/\epsilon} - 1}{e^{1/\epsilon} - 1}. \quad (11.47)$$

This is plotted in fig. 11.3

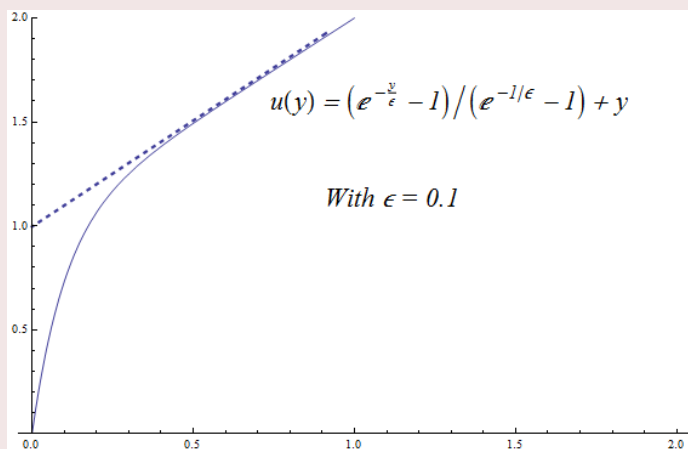

Figure 11.3: Plot of our ill conditioned second order LDE.

Looking for a solution in the regular region, we consider small ϵ relative to y . There our LDE is approximately

$$\frac{du}{dy} = 1, \quad (11.48)$$

which has solution

$$u = y + C. \quad (11.49)$$

Our $u(1) = 2$ boundary value constraint gives us

$$C = 1. \quad (11.50)$$

Our solution in the regular region where $\epsilon \rightarrow 0$ and $y = O(1)$ is therefore just

$$u = y + 1. \quad (11.51)$$

Now let us consider the inner (ill conditioned) region. We will see below that when $y = O(\epsilon)$, and we allow both ϵ and y tend to zero independently, we have approximately

$$u \sim 1 - e^{-y/\epsilon}. \quad (11.52)$$

We will now show this. We start with a helpful change of variables as we did in the first order case

$$Y = \frac{y}{\epsilon}. \quad (11.53)$$

When $y = O(\epsilon)$ and $Y = O(1)$ we have

$$\epsilon \frac{d^2 u}{\epsilon dY^2} + \frac{1}{\epsilon} \frac{du}{dY} = 1, \quad (11.54)$$

or

$$\frac{d^2 u}{dY^2} + \frac{du}{dY} = \epsilon. \quad (11.55)$$

This puts the LDE into a non ill conditioned form, and allows us to let $\epsilon \rightarrow 0$. We have approximately

$$\frac{d^2 u}{dY^2} + \frac{du}{dY} = 0. \quad (11.56)$$

We have solved this in our exact solution work above (in a slightly more general form), and thus in this case we have just

$$u = A + Be^{-Y}. \quad (11.57)$$

At $Y = 0$ we have

$$u = A + B = 0, \quad (11.58)$$

so that

$$B = -A. \quad (11.59)$$

We find for the inner region

$$u = A(1 - e^{-Y}) = A(1 - e^{-y/\epsilon}) \sim 1 - e^{-y/\epsilon}. \quad (11.60)$$

Taking these independent solutions for the inner and outer regions and putting them together into a coherent form (called matched asymptotic expansion) is a rich and tricky field. For info on that we have been referred to [9].

11.3 SUMMARY.

11.3.1 *Singular perturbation theory.*

The non-dimensional form of Navier-Stokes had the form

$$(\mathbf{u} \cdot \nabla)\mathbf{u} = -\nabla p + \frac{1}{\text{Re}} \nabla^2 \mathbf{u}, \quad (11.61)$$

where the inverse of Reynold's number

$$\text{Re} = \frac{UL}{\nu}, \quad (11.62)$$

can potentially get very small. That introduces an ill-conditioning into the problems that can make life more interesting. We looked at a couple of simple LDE systems that had this sort of ill conditioning. One of them was

$$\epsilon \frac{du}{dx} + u = x, \quad (11.63)$$

for which the exact solution was found to be

$$u = (1 + \epsilon)e^{-x/\epsilon} + x - \epsilon \quad (11.64)$$

The rough idea is that we can look in the domain where $x \sim \epsilon$ and far from that. In this example, with x far from the origin we have roughly

$$\epsilon \times 1 + u = x \approx 0 + u, \quad (11.65)$$

so we have an asymptotic solution close to $u = x$. Closer to the origin where $x \sim O(\epsilon)$ we can introduce a rescaling $x = \epsilon y$ to find

$$\epsilon \frac{1}{\epsilon} \frac{du}{dy} + u = \epsilon y. \quad (11.66)$$

This gives us

$$\frac{du}{dy} + u \approx 0, \quad (11.67)$$

for which we find

$$u \propto e^{-y} = e^{-x/\epsilon}. \quad (11.68)$$

THERMAL EFFECTS AND STABILITY.

12.1 STABILITY.

12.1.1 *Stability. Some graphical illustrations.*

What do we mean by stability? A configuration is stable if after a small disturbance it returns to its original position. A couple systems to consider are shown in fig. 12.1, fig. 12.2 and fig. 12.3.

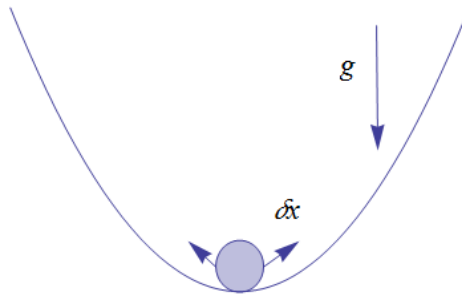

Figure 12.1: Stable well configuration.

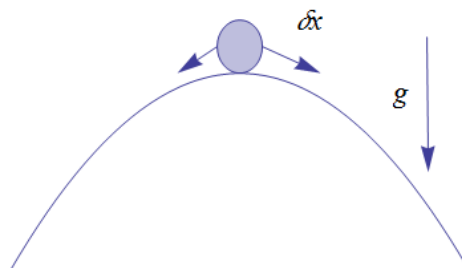

Figure 12.2: Instable peak configuration.

We can examine how a displacement δx changes with time after making it. In a stable configuration without friction we will induce an oscillation as plotted in fig. 12.4 for the parabolic configuration. With friction we will have a damping effect. This is plotted for

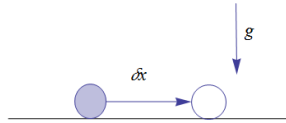

Figure 12.3: Stable tabletop configuration.

the parabolic well in fig. 12.5. For the inverted parabola our

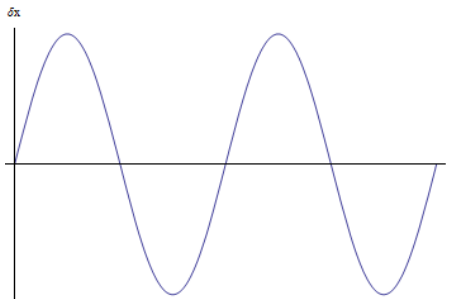

Figure 12.4: Displacement time evolution in undamped well system.

displacement takes the form of fig. 12.6 For the ball on the table, assuming some friction that stops the ball, fairly quickly, we will have a displacement as illustrated in fig. 12.7

12.2 CHARACTERIZING STABILITY.

Let us suppose that our displacement can be described in exponential form

$$\delta x \sim e^{\sigma t}, \tag{12.1}$$

where σ is the *growth rate of perturbation*, and is in general a complex number of the form

$$\sigma = \sigma_R + i\sigma_I. \tag{12.2}$$

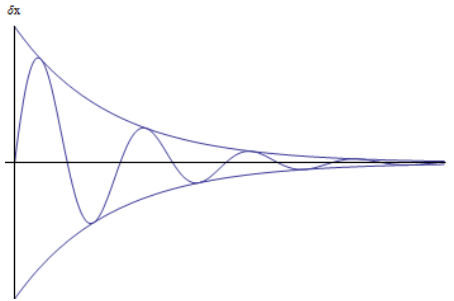

Figure 12.5: Displacement time evolution in damped well system.

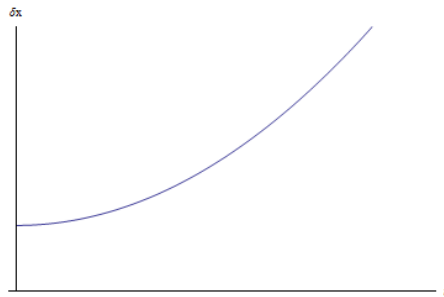

Figure 12.6: Time evolution of displacement in unstable parabolic configuration.

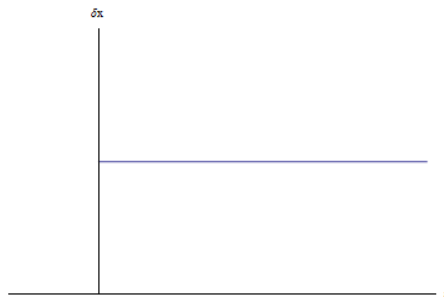

Figure 12.7: Time evolution of displacement in tabletop configuration.

12.2.1 *Case I. Oscillatory instability.*

A system of the form

$$\begin{aligned}\sigma_R &= 0 \\ \sigma_I &> 0.\end{aligned}\tag{12.3}$$

oscillatory unstable. An example of this is the undamped parabolic system illustrated above.

12.2.2 *Case II. Marginal instability.*

$$\begin{aligned}\delta x &\sim e^{\sigma_R t} e^{i\sigma_I t} \\ &\sim e^{\sigma_R t} (\cos \sigma_I t + i \sin \sigma_I t).\end{aligned}\tag{12.4}$$

We will call systems of the form

$$\begin{aligned}\sigma_I &= 0 \\ \sigma_R &> 0,\end{aligned}\tag{12.5}$$

marginally unstable. We can have unstable systems with $\sigma_I \neq 0$ but still $\sigma_R > 0$, but these are less common.

12.2.3 *Case III. Neutral stability.*

$$\begin{aligned}\sigma &= 0 \\ \sigma_R = \sigma_I &= 0.\end{aligned}\tag{12.6}$$

An example of this was the billiard table example where the ball moved to a new location on the table after being bumped slightly.

12.3 A MATHEMATICAL DESCRIPTION.

For a discussion of stability in fluids we will not only have to incorporate the Navier-Stokes equation as we have done, but will also have to bring in the heat equation. Unfortunately that is not in the scope of this course to derive. Let us consider as system heated on a bottom plate, and consider the fluid and convection due to heating. This system is illustrated in fig. 12.8 We start with

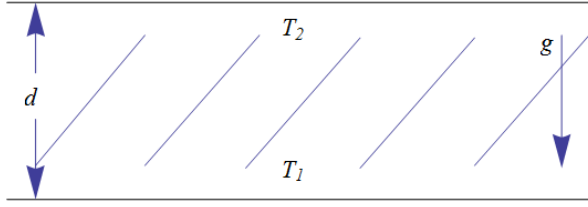

Figure 12.8: Fluid in cavity heated on the bottom plate.

Navier-Stokes as normal

$$\rho \frac{\partial \mathbf{u}}{\partial t} + \rho(\mathbf{u} \cdot \nabla)\mathbf{u} = -\nabla p + \mu \nabla^2 \mathbf{u} - \rho \hat{\mathbf{z}}g. \quad (12.7)$$

For steady state with $\mathbf{u} = 0$ initially (our base state), we will call the following the equation of the base state

$$\nabla p_s = -\rho_s \hat{\mathbf{z}}g. \quad (12.8)$$

We will allow perturbations of each of our variables

$$\begin{aligned} \mathbf{u} &= \mathbf{u}_{\text{base}} + \delta \mathbf{u} = 0 + \delta \mathbf{u} \\ p &= p_s + \delta p \\ \rho &= \rho_s + \delta \rho. \end{aligned} \quad (12.9)$$

After perturbation Navier-Stokes takes the form

$$\begin{aligned} (\rho_s + \delta \rho) \frac{\partial(0 + \delta \mathbf{u})}{\partial t} + (\rho_s + \delta \rho)((0 + \delta \mathbf{u}) \cdot \nabla)(0 + \delta \mathbf{u}) \\ = -\nabla(p_s + \delta p) + \mu \nabla^2(0 + \delta \mathbf{u}) - (\rho_s + \delta \rho)\hat{\mathbf{z}}g. \end{aligned} \quad (12.10)$$

Retaining only terms that are of first order of smallness.

$$\rho_s \frac{\partial \delta \mathbf{u}}{\partial t} = -\nabla p_s - \nabla \delta p + \mu \nabla^2 \delta \mathbf{u} - \rho_s \hat{\mathbf{z}}g - \delta \rho \hat{\mathbf{z}}g, \quad (12.11)$$

applying our equation of base state eq. (12.8), we have

$$\rho_s \frac{\partial \delta \mathbf{u}}{\partial t} = \cancel{\rho_s \hat{\mathbf{z}}g} - \nabla \delta p + \mu \nabla^2 \delta \mathbf{u} - \cancel{\rho_s \hat{\mathbf{z}}g} - \delta \rho \hat{\mathbf{z}}g, \quad (12.12)$$

or

$$\rho_s \frac{\partial \delta \mathbf{u}}{\partial t} = -\nabla \delta p + \mu \nabla^2 \delta \mathbf{u} - \delta \rho \hat{\mathbf{z}}g. \quad (12.13)$$

We can write

$$\left(\frac{\partial}{\partial t} - \nu \nabla^2\right) \delta \mathbf{u} = -\frac{1}{\rho_s} \nabla \delta p - \frac{\delta \rho}{\rho_s} \hat{\mathbf{z}} g. \quad (12.14)$$

Applying the divergence operation on both sides, and using $\nabla \cdot \mathbf{u} = 0$ so that $\nabla \cdot \delta \mathbf{u} = 0$ we have

$$\left(\frac{\partial}{\partial t} - \nu \nabla^2\right) \nabla \cdot \delta \mathbf{u} = -\frac{1}{\rho_s} \nabla^2 \delta p - (\hat{\mathbf{z}} \cdot \nabla) \frac{\delta \rho}{\rho_s} g, \quad (12.15)$$

or

$$\frac{1}{\rho_s} \nabla^2 \delta p = -(\hat{\mathbf{z}} \cdot \nabla) \frac{\delta \rho}{\rho_s} g. \quad (12.16)$$

Assuming that ρ_s is constant (actually that is already been done above), we can cancel it, leaving

$$\nabla^2 \delta p = -(\hat{\mathbf{z}} \cdot \nabla) g \delta \rho = -g \frac{\partial}{\partial z} \delta \rho. \quad (12.17)$$

Operating once more with $\partial/\partial z$ we have

$$\nabla^2 \frac{\partial \delta p}{\partial z} = -g \frac{\partial^2 \delta \rho}{\partial z^2}. \quad (12.18)$$

Going back to eq. (12.14) and taking only the z component we have

$$\left(\frac{\partial}{\partial t} - \nu \nabla^2\right) \delta w = -\frac{1}{\rho_s} \frac{\partial \delta p}{\partial z} - \frac{\delta \rho}{\rho_s} g \quad (12.19)$$

$$\begin{aligned} \left(\frac{\partial}{\partial t} - \nu \nabla^2\right) \nabla^2 \delta w &= -\frac{1}{\rho_s} \frac{\partial \nabla^2 \delta p}{\partial z} - \frac{g}{\rho_s} \nabla^2 \delta \rho \\ &= -\frac{g}{\rho_s} \frac{\partial^2 \delta \rho}{\partial z^2} - \frac{g}{\rho_s} \nabla^2 \delta \rho \\ &= -\frac{g}{\rho_s} \left(\frac{\partial^2}{\partial x^2} + \frac{\partial^2}{\partial y^2} \right) \delta \rho \\ &= g \alpha \left(\frac{\partial^2}{\partial x^2} + \frac{\partial^2}{\partial y^2} \right) \delta T. \end{aligned} \quad (12.20)$$

In the last step we use the following assumed relation for temperature

$$\delta \rho = -\rho_s \alpha \delta T. \quad (12.21)$$

Here α is the coefficient of thermal expansion. This is just a statement that expansion and temperature are related (as we heat something, it expands), with the ratio of the density change relative to the original being linearly related to the change in temperature. We have finally

$$\left(\frac{\partial}{\partial t} - \nu \nabla^2\right) \nabla^2 \delta w = g\alpha \left(\frac{\partial^2}{\partial x^2} + \frac{\partial^2}{\partial y^2}\right) \delta T. \quad (12.22)$$

Solving this is the Rayleigh-Benard instability problem. While this is a fourth order differential equation, it is still the same sort of problem logically as we have been working on. Our boundary value conditions at $z = 0$ are

$$u, v, w, \delta u, \delta v, \delta w = 0. \quad (12.23)$$

Also relevant will be a similar equation relating temperature and fluid flow rate

$$\left(\frac{\partial}{\partial t} - \kappa \nabla^2\right) \delta T = \Delta T \frac{\delta w}{d}, \quad (12.24)$$

which we will cover in the next (and final) lecture of the course.

12.4 THERMAL STABILITY REVIEW. RAYLEIGH BENARD PROBLEM.

Reading: §9.3 from [2].

Illustrated in fig. 12.9 is the heated channel we have been discussing We will take initial conditions

$$\begin{aligned} \frac{\partial \mathbf{u}}{\partial t} &= 0 \\ \frac{\partial T}{\partial t} &= 0, \end{aligned} \quad (12.25)$$

$$\rho \frac{\partial \mathbf{u}}{\partial t} + \rho(\mathbf{u} \cdot \nabla) \mathbf{u} = -\nabla p + \mu \nabla^2 \mathbf{u} + \rho \mathbf{g}. \quad (12.26)$$

Our energy equation is

$$\frac{\partial T}{\partial t} + (\mathbf{u} \cdot \nabla) T = \kappa \nabla^2 T. \quad (12.27)$$

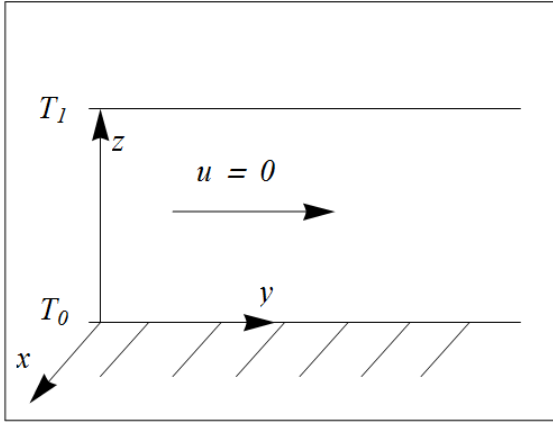

Figure 12.9: Channel with heat applied to the base.

We have this $\mathbf{u} \cdot \nabla$ term because our heat can be carried from one place to the other, due to the fluid motion. We would not have this convective term for heat dissipation in solids because elements of a solid are not moving around in the bulk. In the steady (base) state we have

$$0 = \kappa \nabla^2 T = \kappa \left(\frac{\partial^2}{\partial x^2} + \frac{\partial^2}{\partial y^2} + \frac{\partial^2}{\partial z^2} \right) T, \quad (12.28)$$

but since we are only considering spatial variation with z we have

$$\kappa \frac{\partial^2}{\partial z^2} T_s = 0, \quad (12.29)$$

with solution

$$T_s = T_0 - \frac{\Delta T}{d} z. \quad (12.30)$$

We found that after application of the perturbation

$$\begin{aligned} \mathbf{u} &\rightarrow 0 + \delta \mathbf{u} \\ p &\rightarrow p_s + \delta p \\ \rho &\rightarrow \rho_s + \delta \rho \\ T &\rightarrow T_s + \delta T, \end{aligned} \quad (12.31)$$

to the base state equations, our perturbed Navier-Stokes equation was

$$\nabla^2 \left(\frac{\partial}{\partial t} - \nu \nabla^2 \right) \delta w = g\alpha \left(\frac{\partial^2}{\partial x^2} + \frac{\partial^2}{\partial y^2} \right) \delta T. \quad (12.32)$$

12.5 ENERGY PERTURBATION.

$$\frac{\partial T_s + \delta T}{\partial t} + (\delta \mathbf{u} \cdot \nabla)(T_s + \delta T) = \kappa \nabla^2(T_s + \delta T). \quad (12.33)$$

We have got

$$\frac{\partial T_s}{\partial t} = 0. \quad (12.34)$$

Using this, and eq. (12.29), and neglecting any terms of second order smallness we have

$$\boxed{\frac{\partial \delta T}{\partial t} + \delta \mathbf{u} \cdot \nabla T_s = \kappa \nabla^2 \delta T.} \quad (12.35)$$

We would like to solve this and eq. (12.32) simultaneously.

12.6 NON-DIMENSIONALISATION, THERMAL VELOCITY.

We would like to scale

$$\begin{aligned} x, y, z & \quad \text{with } d \\ t & \quad \text{with } d^2/\nu \\ \delta w & \quad \text{with } \kappa/d \\ \delta T & \quad \text{with } \Delta T. \end{aligned} \quad (12.36)$$

Sanity check of dimensions

- viscosity dimensions

$$[\nu] \sim \left[\frac{1}{\text{T}} \right] / \left[\frac{1}{\text{L}^2} \right] \sim \frac{\text{L}^2}{\text{T}}. \quad (12.37)$$

- thermal conductivity dimensions Since $[\kappa \nabla^2] \sim 1/\text{T}$, we have

$$[\kappa] \sim \frac{\text{L}^2}{\text{T}}. \quad (12.38)$$

- time scaling

$$\left[\frac{d^2}{\nu} \right] \sim \frac{\text{L}^2}{\text{L}^2 \text{T}^{-1}} \sim \text{T}. \quad (12.39)$$

- velocity scaling

$$[\kappa/d] \sim \frac{L^2}{T} \frac{1}{L} \sim [\delta w]. \quad (12.40)$$

Looks like everything checks out. Let us apply this rescaling to our perturbed velocity eq. (12.32)

$$\nabla'^2 \left(\frac{\nu}{d^2} \frac{\partial}{\partial t'} - \frac{\nu}{d^2} \nabla'^2 \right) \frac{\kappa}{d} \delta w' = g\alpha\Delta T \left(\frac{\partial^2}{\partial x'^2} + \frac{\partial^2}{\partial y'^2} \right) \delta T'. \quad (12.41)$$

Introducing the *Rayleigh number*

$$\mathcal{R} = \frac{g\alpha\Delta T d^3}{\nu\kappa}, \quad (12.42)$$

and dropping primes, we have

$$\nabla^2 \left(\frac{\partial}{\partial t} - \nabla^2 \right) \delta w = \mathcal{R} \left(\frac{\partial^2}{\partial x^2} + \frac{\partial^2}{\partial y^2} \right) \delta T. \quad (12.43)$$

My class notes original had \mathcal{R} with the value

$$\frac{g\Delta T d^2}{\nu\alpha},$$

but performing this non-dimensionalization shows that this was either quoted incorrectly, or typed wrong in the heat of the moment. A check against the text shows (equation (9.27)), shows that eq. (12.42) is correct.

12.7 NON-DIMENSIONALIZATION OF THE ENERGY EQUATION.

Rescaling our energy eq. (12.35) we find

$$\frac{\nu}{d^2} \frac{\partial \delta T'}{\partial t'} + \frac{\kappa}{d^2} \delta \mathbf{u}' \cdot \nabla' T'_s = \frac{\kappa}{d^2} \nabla'^2 \delta T'. \quad (12.44)$$

Introducing the *Prandtl number*

$$Pr = \frac{\nu}{\kappa}, \quad (12.45)$$

and dropping primes our non-dimensionalized energy equation takes the form

$$\left(Pr \frac{\partial}{\partial t} - \nabla^2 \right) \delta T = \delta w. \quad (12.46)$$

12.8 NORMAL MODE ANALYSIS.

We have got a pair of nasty looking coupled equations eq. (12.43), and eq. (12.46). Repeated so that we can see them together

$$\nabla^2 \left(\frac{\partial}{\partial t} - \nabla^2 \right) \delta w = \mathcal{R} \left(\frac{\partial^2}{\partial x^2} + \frac{\partial^2}{\partial y^2} \right) \delta T \quad (12.47a)$$

$$\left(P_r \frac{\partial}{\partial t} - \nabla^2 \right) \delta T = \delta w, \quad (12.47b)$$

it is clear that we can decouple these by inserting eq. (12.47b) into eq. (12.47a). Doing that gives us a beastly 6th order spatial equation for the perturbed temperature

$$\left(\frac{\partial}{\partial t} - \nabla^2 \right) \left(P_r \frac{\partial}{\partial t} - \nabla^2 \right) \nabla^2 \delta T = \mathcal{R} \left(\frac{\partial^2}{\partial x^2} + \frac{\partial^2}{\partial y^2} \right) \delta T. \quad (12.48)$$

It is pointed out in the text we have all the x and y derivatives coming together we can apply separation of variables with

$$\delta T = \Theta(z) f(x, y) e^{\sigma t}, \quad (12.49)$$

provided we introduce some restrictions on the form of $f(x, y)$. Here σ (if real) is the growth rate. Applying the Laplacian to this assumed solution we find

$$\nabla^2 \delta T = e^{\sigma t} \left(\Theta''(z) f(x, y) + \Theta(z) \nabla_t^2 f(x, y) \right), \quad (12.50)$$

where

$$\nabla_t^2 = \frac{\partial^2}{\partial x^2} + \frac{\partial^2}{\partial y^2}. \quad (12.51)$$

For eq. (12.50) to be separable we require a constant proportionality

$$\nabla_t^2 f(x, y) \propto f(x, y), \quad (12.52)$$

or

$$\nabla_t^2 f(x, y) \pm k^2 f(x, y) = 0. \quad (12.53)$$

Picking $+k^2$ so that we do not have hyperbolic solutions, f must have the form

$$f(x, y) = e^{i(k_x x + k_y y)}, \quad (12.54)$$

where

$$k^2 = k_x^2 + k_y^2. \quad (12.55)$$

Our separation of variables function now takes the form

$$\delta T = \Theta(z) e^{i(k_1 x + k_2 y) + \sigma t}. \quad (12.56)$$

Writing

$$D = \frac{\partial}{\partial z'}, \quad (12.57)$$

and $\phi = i(k_1 x + k_2 y) + \sigma t$, the beastly equation to solve is

$$\begin{aligned} 0 &= \left(\frac{\partial}{\partial t} - \nabla_t^2 - D^2 \right) \left(P_r \frac{\partial}{\partial t} - \nabla_t^2 - D^2 \right) \left(\nabla_t^2 - D^2 \right) \Theta(z) e^\phi \\ &\quad - \mathcal{R} \nabla_t^2 \Theta(z) e^\phi \\ &= \left((\sigma + k^2 - D^2) (P_r \sigma + k^2 - D^2) (-k^2 - D^2) + \mathcal{R} k^2 \right) \Theta(z) e^\phi \end{aligned} \quad (12.58)$$

This is now an equation for only $\Theta(z)$

$$0 = \left((\sigma + k^2 - D^2) (P_r \sigma + k^2 - D^2) (-k^2 - D^2) + \mathcal{R} k^2 \right) \Theta(z). \quad (12.59)$$

Conceptually we have just a plain old LDE, and should we decide to expand this out we have something of the form

$$0 = \left(\alpha D^6 + \beta D^4 + \gamma D^2 + \zeta \right) \Theta(z). \quad (12.60)$$

Our standard toolbox method to solve this is to assume a solution $\Theta(z) = e^{mz}$ and compute the characteristic equation. We would have to solve

$$0 = \alpha m^6 + \beta m^4 + \gamma m^2 + \zeta. \quad (12.61)$$

Let us back up a bit instead. Looking back to eq. (12.47b), it is clear that we will have the same separable form for our perturbed velocity since we have

$$(P_r\sigma + k^2 - D^2) \Theta(z) e^{i(\mathbf{k}\cdot\mathbf{x})} e^{\sigma t} = \delta w, \quad (12.62)$$

where

$$\mathbf{k} = (k_x, k_y, 0). \quad (12.63)$$

Assuming a solution of the form

$$\delta w = w(z) e^{i(k_1 x + k_2 y) + \sigma t}, \quad (12.64)$$

our velocity is then fully specified in terms of the temperature, since we have

$$w(z) = (P_r\sigma + k^2 - D^2) \Theta(z). \quad (12.65)$$

12.9 BACK TO OUR COUPLED EQUATIONS.

Having gleaned an idea what the form of our solutions is, we can simplify our original coupled system, writing

$$(D^2 - k^2)(\sigma - (D^2 - k^2))w(z) = -\mathcal{R}k^2\Theta(z) \quad (12.66a)$$

$$(D^2 - k^2 - P_r\sigma)\Theta(z) = -w(z). \quad (12.66b)$$

Considering the boundary conditions, if the heating is even then at $z = t = 0$ we can not have any variation with x and y , so can only have $\Theta(0) = 0$. Thus at the boundary, from eq. (12.66a), we have

$$0 = (D^2 - k^2)(\sigma - (D^2 - k^2))w(z)|_{z=0}. \quad (12.67)$$

From the continuity equation $\nabla \cdot \mathbf{u} = 0$, the text argues that we also have $\partial\delta w/\partial z = 0$ on the boundary, so that on that plane we also have

$$0 = w(z) = Dw(z)|_{z=0}. \quad (12.68)$$

Expanding out eq. (12.67) then gives us

$$0 = (D^4 - D^2(2k^2 + \sigma) + k^2(\sigma + k^2))w \Big|_{z=0}, \tag{12.69}$$

or

$$0 = (D^4 - D^2(2k^2 + \sigma))w \Big|_{z=0}. \tag{12.70}$$

These boundary value constraints eq. (12.68), and eq. (12.70), plus the coupled system equations eq. (12.66) are the complete problem to solve. To get a feel for the solution of this system, consider the system with the following simpler set of boundary value constraints

$$w = D^2w = D^4w \Big|_{z=0,1} = 0, \tag{12.71}$$

which in the text is described as the artificial problem of thermal instability for boundaries that are stress free. For such a system on the boundaries $z = 0, 1$ (noting that we are still in dimensionless quantities), we have solutions

$$\begin{aligned} w(z) &= A_n \sin(n\pi z) \\ \Theta(z) &= B_n \sin(n\pi z). \end{aligned} \tag{12.72}$$

Note that we have

$$(D^2 - k^2) \sin(n\pi z) = \left(- (n\pi)^2 - k^2 \right) \sin(n\pi z). \tag{12.73}$$

Inserting eq. (12.72) into our system eq. (12.66), we have

$$\begin{aligned} 0 &= \left(- (n\pi)^2 - k^2 \right) \left(\sigma - \left(- (n\pi)^2 - k^2 \right) \right) A_n \sin(n\pi z) \\ &\quad + \mathcal{R}k^2 B_n \sin(n\pi z) \end{aligned} \tag{12.74}$$

$$0 = \left(- (n\pi)^2 - k^2 - P_r\sigma \right) B_n \sin(n\pi z) + A_n \sin(n\pi z).$$

For any A_n, B_n , we must then have

$$0 = \begin{vmatrix} (n^2\pi^2 + k^2)^2 + \sigma(n^2\pi^2 + k^2) & -\mathcal{R}k^2 \\ -1 & n^2\pi^2 + k^2 + P_r\sigma \end{vmatrix}. \tag{12.75}$$

For $\sigma = 0$, this gives us the critical value for the Rayleigh number

$$\mathcal{R} = \frac{(k^2 + n^2\pi^2)^3}{k^2}, \tag{12.76}$$

the value that separates our stable and unstable solutions. On the other hand for

- $\text{Re}(\sigma) > 0$ ($\Delta T > \Delta T_e$), we have an instable system.
- $\text{Re}(\sigma) < 0$ ($\Delta T > \Delta T_e$), we have a stable system.

This is illustrated in fig. 12.10. The instability means that we will

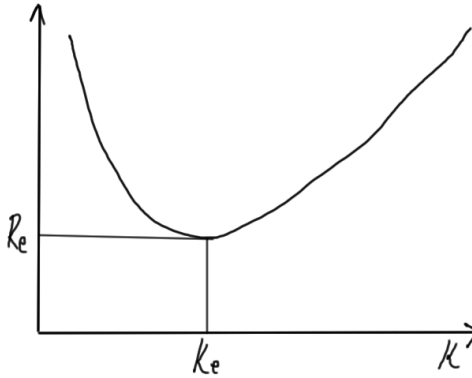

Figure 12.10: Critical Rayleigh's number.

have instable flows as illustrated in fig. 12.11. Solving for these

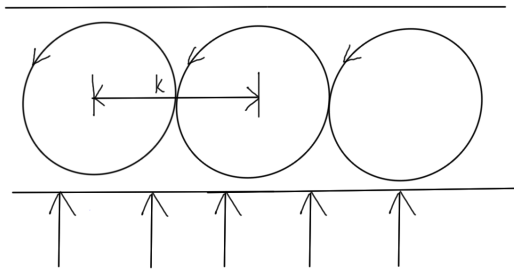

Figure 12.11: Instability due to heating.

critical points we find

$$k_e^2 = \frac{\pi^2}{2}, \quad (12.77a)$$

$$\mathcal{R}_e = \frac{27\pi^4}{4}. \quad (12.77b)$$

12.10 MULTIMEDIA PRESENTATIONS.

- Kelvin-Helmholtz instability. Colored salt water underneath, with unsalted water on top. Apparatus tilted causing flow of one over the other. Instability of the interface.

See [23] for a really cool animation of a simulation of this effect. It ends up looking very fractal. Also interesting is the picture of this observed for real in the atmosphere of Saturn.

- A simulated mushroom cloud occurring with one fluid seeping into another. This looks it matches what we find under Rayleigh-Taylor instability in [25].
- plume, motion up through a denser fluid.
- Plateau-Rayleigh instability. Drop pinching off. See instability in the fluid channel feeding the drop. A crude illustration of this can be found in fig. 12.12. A better illustrations (and

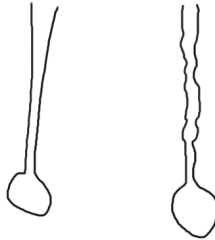

Figure 12.12: Crude illustration of instability leading to a drop pinching off.

animations) can be found in [24].

- Jet of water injected into a rotating tub on a turntable. Jet forms and surfaces.

12.11 SUMMARY.

12.11.1 *Stability.*

We characterized stability in terms of displacements writing

$$\delta x = e^{(\sigma_R + i\sigma_I)t}, \quad (12.78)$$

and defining

1. Oscillatory unstability. $\sigma_R = 0, \sigma_I > 0$.
2. Marginal unstability. $\sigma_I = 0, \sigma_R > 0$.
3. Neutral stability. $\sigma_I = 0, \sigma_R = 0$.

12.11.2 *Thermal stability: Rayleigh-Benard problem.*

We considered the Rayleigh-Benard problem, looking at thermal effects in a cavity. Assuming perturbations of the form

$$\begin{aligned} \mathbf{u} &= \mathbf{u}_{\text{base}} + \delta \mathbf{u} = 0 + \delta \mathbf{u} \\ p &= p_s + \delta p \\ \rho &= \rho_s + \delta \rho, \end{aligned} \quad (12.79)$$

and introducing an equation for the base state

$$\nabla p_s = -\rho_s \hat{\mathbf{z}} g, \quad (12.80)$$

we found

$$\left(\frac{\partial}{\partial t} - \nu \nabla^2 \right) \delta \mathbf{u} = -\frac{1}{\rho_s} \nabla \delta p - \frac{\delta \rho}{\rho_s} \hat{\mathbf{z}} g. \quad (12.81)$$

Operating on this with $\partial/\partial z \nabla \cdot ()$ we find

$$\nabla^2 \frac{\partial \delta p}{\partial z} = -g \frac{\partial^2 \delta \rho}{\partial z^2}, \quad (12.82)$$

from which we apply back to eq. (12.81) and take just the z component to find

$$\left(\frac{\partial}{\partial t} - \nu \nabla^2 \right) \delta w = -\frac{1}{\rho_s} \frac{\partial \delta p}{\partial z} - \frac{\delta \rho}{\rho_s} g. \quad (12.83)$$

With an assumption that density change and temperature are linearly related

$$\delta\rho = -\rho_s\alpha\delta T, \quad (12.84)$$

and operating with the Laplacian we end up with a relation that follows from the momentum balance equation

$$\left(\frac{\partial}{\partial t} - \nu\nabla^2\right)\nabla^2\delta w = g\alpha\left(\frac{\partial^2}{\partial x^2} + \frac{\partial^2}{\partial y^2}\right)\delta T. \quad (12.85)$$

We also applied our perturbation to the energy balance equation

$$\frac{\partial T}{\partial t} + (\mathbf{u} \cdot \nabla)T = \kappa\nabla^2 T. \quad (12.86)$$

We determined that the base state temperature obeyed

$$\kappa\frac{\partial^2}{\partial z^2}T_s = 0, \quad (12.87)$$

with solution

$$T_s = T_0 - \frac{\Delta T}{d}z. \quad (12.88)$$

This and application of the perturbation gave us

$$\frac{\partial\delta T}{\partial t} + \delta\mathbf{u} \cdot \nabla T_s = \kappa\nabla^2\delta T. \quad (12.89)$$

We used this to non-dimensionalize with

$$\begin{aligned} x, y, z & \quad \text{with } d \\ t & \quad \text{with } d^2/\nu \\ \delta w & \quad \text{with } \kappa/d \\ \delta T & \quad \text{with } \Delta T, \end{aligned} \quad (12.90)$$

and found (primes dropped)

$$\nabla^2\left(\frac{\partial}{\partial t} - \nabla^2\right)\delta w = \mathcal{R}\left(\frac{\partial^2}{\partial x^2} + \frac{\partial^2}{\partial y^2}\right)\delta T, \quad (12.91a)$$

$$\left(\text{Pr}\frac{\partial}{\partial t} - \nabla^2\right)\delta T = \delta w, \quad (12.91b)$$

where we have introduced the Rayleigh number and Prandtl number's

$$\mathcal{R} = \frac{g\alpha\Delta T d^3}{\nu\kappa}, \quad (12.92a)$$

$$P_r = \frac{\nu}{\kappa}. \quad (12.92b)$$

We were able to construct some approximate solutions for a problem similar to these equations using an assumed solution form

$$\begin{aligned} \delta w &= w(z)e^{i(k_1x+k_2y)+\sigma t} \\ \delta T &= \Theta(z)e^{i(k_1x+k_2y)+\sigma t}. \end{aligned} \quad (12.93)$$

Using these we are able to show that our PDEs are similar to that of

$$w = D^2w = D^4w \Big|_{z=0,1} = 0, \quad (12.94)$$

where $D = \partial/\partial z$. Using the trig solutions that fall out of this we were able to find the constraint

$$0 = \begin{vmatrix} (n^2\pi^2 + k^2)^2 + \sigma(n^2\pi^2 + k^2) & -\mathcal{R}k^2 \\ -1 & n^2\pi^2 + k^2 + P_r\sigma \end{vmatrix}, \quad (12.95)$$

which for $\sigma = 0$, this gives us the critical value for the Rayleigh number

$$\mathcal{R} = \frac{(k^2 + n^2\pi^2)^3}{k^2}, \quad (12.96)$$

which is the boundary for thermal stability or instability.

The end result was a lot of manipulation for which we did not do any sort of applied problems. It looks like a theory that requires a lot of study to do anything useful with, so my expectation is that it will not be covered in detail on the exam. Having some problems to know why we spent two days on it in class would have been nice.

12.12 PROBLEMS.

Exercise 12.1 Rayleigh number. (2012 ps4)

What is the physical meaning of the Rayleigh number?

Exercise 12.2 Critical temperature. (2012 ps4)

If $R_c = \frac{27\pi^4}{4}$ is the critical Rayleigh number for the onset of convection for water, what is the corresponding critical temperature difference between the top and bottom plates in a 10cm layer of fluid?

Exercise 12.3 Critical wavelength. (2012 ps4)

What is the dimensional value of the critical wavelength of the convection cells?

Exercise 12.4 Rigid plates. (2012 ps4)

If instead of taking stress free boundary conditions at the top and bottom plates, if we consider both the plates 'rigid' (no-slip) how does the solution of eq. (12.65) change?

Exercise 12.5 Normal mode solutions. (2012 ps4)

Consider the problem

$$\frac{\partial u}{\partial t} - \sin u = \frac{1}{R} \frac{\partial^2 u}{\partial y^2}, \quad (12.97)$$

where R is a real parameter and the boundary conditions are given by

$$u(y = 0, t) = u(y = \pi, t) = 0, \quad (12.98)$$

for all time t . Examine the trivial base state $u = u_B(y) = 0$ by seeking normal mode solutions to the linearized perturbed equations. Find the eigenfunctions and eigenvalues and show that the base state is linearly stable only if $R \leq 1$.

A

STRAIN (NON-RECTANGULAR).

A.1 CYLINDRICAL COORDINATES.

At the end of the section in the text, the formulas for the spherical and cylindrical versions (to first order) of the strain tensor is given without derivation. Let us do that derivation for the cylindrical case, which is simpler. It appears that use of explicit vector notation is helpful here, so we write

$$\begin{aligned}\mathbf{x} &= r\hat{\mathbf{r}} + z\hat{\mathbf{z}} \\ \mathbf{u} &= u_r\hat{\mathbf{r}} + u_\phi\hat{\boldsymbol{\phi}} + u_z\hat{\mathbf{z}},\end{aligned}\tag{A.1}$$

where

$$\begin{aligned}\hat{\mathbf{r}} &= \mathbf{e}_1 e^{i\phi} \\ \hat{\boldsymbol{\phi}} &= \mathbf{e}_2 e^{i\phi} \\ i &= \mathbf{e}_1 \mathbf{e}_2.\end{aligned}\tag{A.2}$$

Since $\hat{\mathbf{r}}$ and $\hat{\boldsymbol{\phi}}$ are functions of position, we will need their differentials

$$\begin{aligned}d\hat{\mathbf{r}} &= \mathbf{e}_1 \mathbf{e}_1 \mathbf{e}_2 e^{i\phi} d\phi = \mathbf{e}_2 e^{i\phi} d\phi \\ d\hat{\boldsymbol{\phi}} &= \mathbf{e}_2 \mathbf{e}_1 \mathbf{e}_2 e^{i\phi} d\phi = -\mathbf{e}_2 e^{i\phi} d\phi,\end{aligned}\tag{A.3}$$

but these are just scaled basis vectors

$$\begin{aligned}d\hat{\mathbf{r}} &= \hat{\boldsymbol{\phi}} d\phi \\ d\hat{\boldsymbol{\phi}} &= -\hat{\mathbf{r}} d\phi.\end{aligned}\tag{A.4}$$

So for our \mathbf{x} and \mathbf{u} differentials we find

$$\begin{aligned}d\mathbf{x} &= dr\hat{\mathbf{r}} + r d\hat{\mathbf{r}} + dz\hat{\mathbf{z}} \\ &= dr\hat{\mathbf{r}} + r\hat{\boldsymbol{\phi}} d\phi + dz\hat{\mathbf{z}},\end{aligned}\tag{A.5}$$

and

$$\begin{aligned}d\mathbf{u} &= du_r\hat{\mathbf{r}} + du_\phi\hat{\boldsymbol{\phi}} + du_z\hat{\mathbf{z}} + u_r\hat{\boldsymbol{\phi}} d\phi - u_\phi\hat{\mathbf{r}} d\phi \\ &= \hat{\mathbf{r}}(du_r - u_\phi d\phi) + \hat{\boldsymbol{\phi}}(du_\phi + u_r d\phi) + \hat{\mathbf{z}}(du_z).\end{aligned}\tag{A.6}$$

Putting these together we have

$$\begin{aligned} d\mathbf{l}' &= d\mathbf{u} + d\mathbf{x} \\ &= \hat{\mathbf{r}}(du_r - u_\phi d\phi + dr) + \hat{\boldsymbol{\phi}}(du_\phi + u_r d\phi + rd\phi) + \hat{\mathbf{z}}(du_z + dz). \end{aligned} \quad (\text{A.7})$$

For the squared magnitude's difference from $d\mathbf{x}^2$ we have

$$\begin{aligned} (d\mathbf{l}')^2 - d\mathbf{x}^2 &= (du_r - u_\phi d\phi + dr)^2 \\ &\quad + (du_\phi + u_r d\phi + rd\phi)^2 + (du_z + dz)^2 - dr^2 - r^2 d\phi^2 - dz^2 \\ &= (du_r - u_\phi d\phi)^2 + 2dr(du_r - u_\phi d\phi) + (du_\phi + u_r d\phi)^2 \\ &\quad + 2rd\phi(du_\phi + u_r d\phi) + du_z^2 + 2du_z dz. \end{aligned} \quad (\text{A.8})$$

Expanding this out, but dropping all the terms that are quadratic in the components of \mathbf{u} or its differentials, we have

$$\begin{aligned} (d\mathbf{l}')^2 - d\mathbf{x}^2 &\approx 2dr(du_r - u_\phi d\phi) + 2rd\phi(du_\phi + u_r d\phi) + 2du_z dz \\ &= 2drdu_r - 2dr u_\phi d\phi + 2rd\phi du_\phi + 2rd\phi u_r d\phi + 2du_z dz \\ &= 2dr \left(\frac{\partial u_r}{\partial r} dr + \frac{\partial u_r}{\partial \phi} d\phi + \frac{\partial u_r}{\partial z} dz \right) \\ &\quad - 2drd\phi u_\phi \\ &\quad + 2rd\phi \left(\frac{\partial u_\phi}{\partial r} dr + \frac{\partial u_\phi}{\partial \phi} d\phi + \frac{\partial u_\phi}{\partial z} dz \right) \\ &\quad + 2rd\phi d\phi u_r \\ &\quad + 2dz \left(\frac{\partial u_z}{\partial r} dr + \frac{\partial u_z}{\partial \phi} d\phi + \frac{\partial u_z}{\partial z} dz \right). \end{aligned} \quad (\text{A.9})$$

Grouping all terms, with all the second order terms neglected, we have

$$\begin{aligned} (d\mathbf{l}')^2 - d\mathbf{x}^2 &= 2drdr \frac{\partial u_r}{\partial r} + 2r^2 d\phi d\phi \left(\frac{1}{r} \frac{\partial u_\phi}{\partial \phi} + \frac{1}{r} u_r \right) + 2dzdz \frac{\partial u_z}{\partial z} \\ &\quad + 2dzdr \left(\frac{\partial u_r}{\partial z} + \frac{\partial u_z}{\partial r} \right) + 2drd\phi \left(\frac{\partial u_\phi}{\partial r} - \frac{1}{r} u_\phi + \frac{1}{r} \frac{\partial u_r}{\partial \phi} \right) \\ &\quad + 2dzrd\phi \left(\frac{\partial u_\phi}{\partial z} + \frac{1}{r} \frac{\partial u_z}{\partial \phi} \right). \end{aligned} \quad (\text{A.10})$$

From this we can read off the result quoted in the text

$$\begin{aligned}
 2e_{rr} &= \frac{\partial u_r}{\partial r} \\
 2e_{\phi\phi} &= \frac{1}{r} \frac{\partial u_\phi}{\partial \phi} + \frac{1}{r} u_r \\
 2e_{zz} &= \frac{\partial u_z}{\partial z} \\
 2e_{zr} &= \frac{\partial u_r}{\partial z} + \frac{\partial u_z}{\partial r} \\
 2e_{r\phi} &= \frac{\partial u_\phi}{\partial r} - \frac{1}{r} u_\phi + \frac{1}{r} \frac{\partial u_r}{\partial \phi} \\
 2e_{\phi z} &= \frac{\partial u_\phi}{\partial z} + \frac{1}{r} \frac{\partial u_z}{\partial \phi}.
 \end{aligned} \tag{A.11}$$

Observe that we have to introduce factors of r along with all the $d\phi$'s, when we factored out the tensor components. That is an important looking detail, which is not obvious unless one works through the derivation.

Note that in class we retained the second order terms. That becomes a messier calculation (see [strainTensorCylindrical.cdf](#))

$$\begin{aligned}
 (dl')^2 - dx^2 &= (dr)^2 \left(2 \frac{\partial u_r}{\partial r} + \left(\frac{\partial u_r}{\partial r} \right)^2 + \left(\frac{\partial u_z}{\partial r} \right)^2 + \left(\frac{\partial u_\phi}{\partial r} \right)^2 \right) \\
 &+ (d\phi)^2 \left(2ru_r + u_r^2 + u_\phi^2 - 2u_\phi \frac{\partial u_r}{\partial \phi} + \left(\frac{\partial u_r}{\partial \phi} \right)^2 + \left(\frac{\partial u_z}{\partial \phi} \right)^2 \right. \\
 &\quad \left. + 2r \frac{\partial u_\phi}{\partial \phi} + 2u_r \frac{\partial u_\phi}{\partial \phi} + \left(\frac{\partial u_\phi}{\partial \phi} \right)^2 \right) \\
 &+ (dz)^2 \left(\left(\frac{\partial u_r}{\partial z} \right)^2 + 2 \frac{\partial u_z}{\partial z} + \left(\frac{\partial u_z}{\partial z} \right)^2 + \left(\frac{\partial u_\phi}{\partial z} \right)^2 \right) \\
 &+ drd\phi \left(-2u_\phi - 2u_\phi \frac{\partial u_r}{\partial r} + 2 \frac{\partial u_r}{\partial \phi} + 2 \frac{\partial u_r}{\partial r} \frac{\partial u_r}{\partial \phi} + 2 \frac{\partial u_z}{\partial r} \frac{\partial u_z}{\partial \phi} \right. \\
 &\quad \left. + 2r \frac{\partial u_\phi}{\partial r} + 2u_r \frac{\partial u_\phi}{\partial r} + 2 \frac{\partial u_\phi}{\partial r} \frac{\partial u_\phi}{\partial \phi} \right) \\
 &+ dzd\phi \left(-2u_\phi \frac{\partial u_r}{\partial z} + 2 \frac{\partial u_r}{\partial z} \frac{\partial u_r}{\partial \phi} + 2 \frac{\partial u_z}{\partial \phi} + 2 \frac{\partial u_z}{\partial z} \frac{\partial u_z}{\partial \phi} \right. \\
 &\quad \left. + 2r \frac{\partial u_\phi}{\partial z} + 2u_r \frac{\partial u_\phi}{\partial z} + 2 \frac{\partial u_\phi}{\partial z} \frac{\partial u_\phi}{\partial \phi} \right) + drdz \left(2 \frac{\partial u_r}{\partial z} \right. \\
 &\quad \left. + 2 \frac{\partial u_r}{\partial r} \frac{\partial u_r}{\partial z} + 2 \frac{\partial u_z}{\partial r} + 2 \frac{\partial u_z}{\partial r} \frac{\partial u_z}{\partial z} + 2 \frac{\partial u_\phi}{\partial r} \frac{\partial u_\phi}{\partial z} \right).
 \end{aligned} \tag{A.12}$$

As with the first order case, we can read off the tensor coordinates by inspection (once we factor out the various factors of 2 and r). The next logical step would be to do the spherical tensor calculation. That would likely be particularly messy if we attempted it in the brute force fashion. Let us step back and look at the general case, before tackling there spherical polar form explicitly.

A.2 FOR GENERAL COORDINATE REPRESENTATION.

Now let us dispense with the assumption that we have an orthonormal frame. Given an arbitrary, not necessarily orthonormal, position dependent frame $\{e_\mu\}$, and its reciprocal frame $\{e^\mu\}$, as defined by

$$e_\mu \cdot e^\nu = \delta_\mu^\nu. \tag{A.13}$$

Our coordinate representation, with summation and dimensionality implied, is

$$\begin{aligned}\mathbf{x} &= x^\mu e_\mu = x_\nu e^\nu \\ \mathbf{u} &= u^\mu e_\mu = u_\nu e^\nu.\end{aligned}\tag{A.14}$$

Our differentials are

$$\begin{aligned}d\mathbf{x} &= dx^\mu e_\mu + x^\mu de_\mu \\ &= \sum_\alpha d\alpha \left(\frac{\partial x^\mu}{\partial \alpha} e_\mu + x^\mu \frac{\partial e_\mu}{\partial \alpha} \right),\end{aligned}\tag{A.15}$$

and

$$\begin{aligned}d\mathbf{u} &= du^\mu e_\mu + u^\mu de_\mu \\ &= \sum_\alpha d\alpha \left(\frac{\partial u^\mu}{\partial \alpha} e_\mu + u^\mu \frac{\partial e_\mu}{\partial \alpha} \right).\end{aligned}\tag{A.16}$$

Summing these we have

$$d\mathbf{u} + d\mathbf{x} = \sum_\alpha d\alpha \left(\left(\frac{\partial x^\mu}{\partial \alpha} + \frac{\partial u^\mu}{\partial \alpha} \right) e_\mu + (x^\mu + u^\mu) \frac{\partial e_\mu}{\partial \alpha} \right).\tag{A.17}$$

Taking dot products to form the squares we have

$$\begin{aligned}d\mathbf{x}^2 &= \sum_{\alpha, \beta} d\alpha d\beta \left(\frac{\partial x^\mu}{\partial \alpha} e_\mu + x^\mu \frac{\partial e_\mu}{\partial \alpha} \right) \cdot \left(\frac{\partial x_\nu}{\partial \beta} e^\nu + x_\nu \frac{\partial e^\nu}{\partial \beta} \right) \\ &= \sum_{\alpha, \beta} d\alpha d\beta \left(\frac{\partial x^\mu}{\partial \alpha} \frac{\partial x_\mu}{\partial \beta} + x^\mu x_\nu \frac{\partial e_\mu}{\partial \alpha} \cdot \frac{\partial e^\nu}{\partial \beta} + 2 \frac{\partial x^\mu}{\partial \alpha} x_\nu e_\mu \cdot \frac{\partial e^\nu}{\partial \beta} \right),\end{aligned}\tag{A.18}$$

and

$$\begin{aligned}(d\mathbf{u} + d\mathbf{x})^2 &= \sum_{\alpha, \beta} d\alpha d\beta \left(\left(\frac{\partial x^\mu}{\partial \alpha} + \frac{\partial u^\mu}{\partial \alpha} \right) e_\mu + (x^\mu + u^\mu) \frac{\partial e_\mu}{\partial \alpha} \right) \\ &\quad \cdot \left(\left(\frac{\partial x_\nu}{\partial \beta} + \frac{\partial u_\nu}{\partial \beta} \right) e^\nu + (x_\nu + u_\nu) \frac{\partial e^\nu}{\partial \beta} \right) \\ &= \sum_{\alpha, \beta} d\alpha d\beta \left(\left(\frac{\partial x^\mu}{\partial \alpha} + \frac{\partial u^\mu}{\partial \alpha} \right) \left(\frac{\partial x_\mu}{\partial \beta} + \frac{\partial u_\mu}{\partial \beta} \right) \right. \\ &\quad \left. + (x^\mu + u^\mu) (x_\nu + u_\nu) \frac{\partial e_\mu}{\partial \alpha} \cdot \frac{\partial e^\nu}{\partial \beta} + 2 (x^\mu + u^\mu) e^\nu \right. \\ &\quad \left. \cdot \frac{\partial e_\mu}{\partial \alpha} \left(\frac{\partial x_\nu}{\partial \beta} + \frac{\partial u_\nu}{\partial \beta} \right) \right).\end{aligned}$$

Taking the difference we find

$$\begin{aligned}
 (d\mathbf{u} + d\mathbf{x})^2 - d\mathbf{x}^2 &= \sum_{\alpha, \beta} d\alpha d\beta \left(\frac{\partial u^\mu}{\partial \alpha} \frac{\partial u_\mu}{\partial \beta} + 2 \frac{\partial u^\mu}{\partial \alpha} \frac{\partial x_\mu}{\partial \beta} \right. \\
 &\quad \left. + (u^\mu u_\nu + x^\mu u_\nu + u^\mu x_\nu) \frac{\partial e_\mu}{\partial \alpha} \cdot \frac{\partial e^\nu}{\partial \beta} \right) \\
 &\quad + 2 \left(\frac{\partial x^\mu}{\partial \alpha} u_\nu + \frac{\partial u^\mu}{\partial \alpha} (x_\nu + u_\nu) \right) e_\mu \cdot \frac{\partial e^\nu}{\partial \beta}.
 \end{aligned}$$

To evaluate this, it is useful, albeit messier, to group terms a bit

$$\begin{aligned}
 (d\mathbf{u} + d\mathbf{x})^2 - d\mathbf{x}^2 &= \sum_{\alpha} 2d\alpha d\alpha \left(\frac{1}{2} \frac{\partial u^\mu}{\partial \alpha} \frac{\partial u_\mu}{\partial \alpha} + \frac{\partial u^\mu}{\partial \alpha} \frac{\partial x_\mu}{\partial \alpha} \right. \\
 &\quad \left. + \frac{1}{2} (u^\mu u_\nu + x^\mu u_\nu + u^\mu x_\nu) \frac{\partial e_\mu}{\partial \alpha} \cdot \frac{\partial e^\nu}{\partial \alpha} \right. \\
 &\quad \left. + \left(\frac{\partial x^\mu}{\partial \alpha} u_\nu + \frac{\partial u^\mu}{\partial \alpha} (x_\nu + u_\nu) \right) e_\mu \cdot \frac{\partial e^\nu}{\partial \alpha} \right) \\
 &\quad + \sum_{\alpha < \beta} 2d\alpha d\beta \left(\frac{\partial u^\mu}{\partial \alpha} \frac{\partial u_\mu}{\partial \beta} + \frac{\partial u^\mu}{\partial \alpha} \frac{\partial x_\mu}{\partial \beta} + \frac{\partial u^\mu}{\partial \beta} \frac{\partial x_\mu}{\partial \alpha} \right. \\
 &\quad \left. + \frac{1}{2} (u^\mu u_\nu + x^\mu u_\nu + u^\mu x_\nu) \left(\frac{\partial e_\mu}{\partial \alpha} \cdot \frac{\partial e^\nu}{\partial \beta} + \frac{\partial e_\mu}{\partial \beta} \cdot \frac{\partial e^\nu}{\partial \alpha} \right) \right) \\
 &\quad + \sum_{\alpha < \beta} 2d\alpha d\beta \left(\left(\frac{\partial x^\mu}{\partial \alpha} u_\nu + \frac{\partial u^\mu}{\partial \alpha} (x_\nu + u_\nu) \right) e_\mu \cdot \frac{\partial e^\nu}{\partial \beta} \right. \\
 &\quad \left. + \left(\frac{\partial x^\mu}{\partial \beta} u_\nu + \frac{\partial u^\mu}{\partial \beta} (x_\nu + u_\nu) \right) e_\mu \cdot \frac{\partial e^\nu}{\partial \alpha} \right).
 \end{aligned} \tag{A.20}$$

Here $\alpha < \beta$ is used to denote summation over the pairs $\alpha \neq \beta$ just once, not necessarily any numeric ordering. For example with $\alpha, \beta \in \{r, \phi, z\}$, this could be the set $\{\alpha, \beta\} \in \{r\phi, \phi z, zr\}$.

A.3 CARTESIAN TENSOR.

In the Cartesian case all the partials of the unit vectors are zero, and we also have no need of upper or lower indices. We are left with just

$$(d\mathbf{u} + d\mathbf{x})^2 - d\mathbf{x}^2 = \sum_{i,j,k} dx^i dx^j \left(\frac{\partial u^k}{\partial x^i} \frac{\partial u^k}{\partial x^j} + 2 \frac{\partial u^k}{\partial x^i} \frac{\partial x^k}{\partial x^j} \right). \tag{A.21}$$

However, since we also have $\partial x^k / \partial x^j = \delta_{jk}$, this is

$$(d\mathbf{u} + d\mathbf{x})^2 - d\mathbf{x}^2 = \sum_{i,j} 2dx^i dx^j \left(\frac{1}{2} \sum_k \frac{\partial u^k}{\partial x^i} \frac{\partial u^k}{\partial x^j} + \frac{\partial u^j}{\partial x^i} \right). \quad (\text{A.22})$$

This essentially recovers the result eq. (2.13) derived in class.

A.4 CYLINDRICAL TENSOR.

Now lets do the cylindrical tensor again, but this time without resorting Mathematica brute force.

First we recall that all our basis vector derivatives are zero except for the ϕ derivatives, and for those we have

$$\begin{aligned} \frac{\partial \hat{\mathbf{r}}}{\partial \phi} &= \hat{\boldsymbol{\phi}} \\ \frac{\partial \hat{\boldsymbol{\theta}}}{\partial \phi} &= -\hat{\mathbf{r}}. \end{aligned} \quad (\text{A.23})$$

If we write

$$\mathbf{x} = r\hat{\mathbf{r}} + z\hat{\mathbf{z}} = x_r\hat{\mathbf{r}} + x_\phi\hat{\boldsymbol{\phi}} + x_z\hat{\mathbf{z}}, \quad (\text{A.24})$$

we have for all the x^μ partials

$$\frac{\partial x^\mu}{\partial \alpha} = \begin{cases} 1 & \text{if } \alpha = x^\mu = r \text{ or } \alpha = x^\mu = z \\ 0 & \text{otherwise.} \end{cases} \quad (\text{A.25})$$

We are now set to evaluate the terms in the sum of eq. (A.20) for the cylindrical coordinate system and should not need Mathematica to do it. Let us do this one at a time, starting with all the squared differential pairs. Those are, for $\alpha \in \{r, \phi, z\}$ the value of

$$\begin{aligned} 2d\alpha d\alpha \left(\frac{1}{2} \frac{\partial u_m}{\partial \alpha} \frac{\partial u_m}{\partial \alpha} + \frac{\partial u_m}{\partial \alpha} \frac{\partial x_m}{\partial \alpha} + \frac{1}{2} (u_m u_n + x_m u_n + u_m x_n) \frac{\partial e_m}{\partial \alpha} \right. \\ \left. \cdot \frac{\partial e_n}{\partial \alpha} + \left(\frac{\partial x_m}{\partial \alpha} u_n + \frac{\partial u_m}{\partial \alpha} (x_n + u_n) \right) e_m \cdot \frac{\partial e_n}{\partial \alpha} \right). \end{aligned} \quad (\text{A.26})$$

For both r and z all our unit vectors have zero derivatives so we are left respectively with

$$2drdr \left(\frac{1}{2} \frac{\partial u_m}{\partial r} \frac{\partial u_m}{\partial r} + \frac{\partial u_r}{\partial r} \right), \quad (\text{A.27})$$

and

$$2dzdz \left(\frac{1}{2} \frac{\partial u_m}{\partial z} \frac{\partial u_m}{\partial z} + \frac{\partial u_z}{\partial z} \right). \quad (\text{A.28})$$

For the $\alpha = \phi$ term we have

$$\begin{aligned} 2d\phi d\phi & \left(\frac{1}{2} \frac{\partial u_m}{\partial \phi} \frac{\partial u_m}{\partial \phi} + \frac{1}{2} \sum_{m=r,\phi} (u_m u_m + 2x_m u_m) \right. \\ & + \sum_{mn \in \{r\phi, \phi r\}} \left(\frac{\partial x_m}{\partial \phi} u_n + \frac{\partial u_m}{\partial \phi} (x_n + u_n) \right) e_m \\ & \cdot \left. \frac{\partial e_n}{\partial \phi} \right) = 2d\phi d\phi \left(\frac{1}{2} \frac{\partial u_m}{\partial \phi} \frac{\partial u_m}{\partial \phi} + \frac{1}{2} (u_r^2 + u_\phi^2) + ru_r - \frac{\partial u_r}{\partial \phi} u_\phi \right. \\ & \left. + \frac{\partial u_\phi}{\partial \phi} (r + u_r) \right). \end{aligned}$$

Now, on to the mixed terms. The easiest is the $dzdr$ term, for which all the unit vector derivatives are zero, and we are left with just

$$\begin{aligned} 2dzdr & \left(\frac{\partial u_m}{\partial z} \frac{\partial u_m}{\partial r} + \frac{\partial u_m}{\partial z} \frac{\partial x_m}{\partial r} + \frac{\partial u_m}{\partial r} \frac{\partial x_m}{\partial z} \right) \\ & = 2dzdr \left(\frac{\partial u_m}{\partial z} \frac{\partial u_m}{\partial r} + \frac{\partial u_r}{\partial z} + \frac{\partial u_z}{\partial r} \right). \end{aligned} \quad (\text{A.29})$$

Now we have the two messy mixed terms. For the r, ϕ term we get

$$\begin{aligned}
 & 2drd\phi \left(\frac{\partial u_m}{\partial r} \frac{\partial u_m}{\partial \phi} + \frac{\partial u_m}{\partial r} \frac{\partial x'_m}{\partial \phi} + \frac{\partial u_m}{\partial \phi} \frac{\partial x_m}{\partial r} \right. \\
 & \quad \left. + \frac{1}{2} (u_m u_n + x_m u_n + u_m x_n) \left(\frac{\partial e'_m}{\partial r} \cdot \frac{\partial e_n}{\partial \phi} + \frac{\partial e_m}{\partial \phi} \cdot \frac{\partial e'_n}{\partial r} \right) \right) \\
 & \quad + 2drd\phi \left(\left(\frac{\partial x_m}{\partial r} u_n + \frac{\partial u_m}{\partial r} (x_n + u_n) \right) e_m \cdot \frac{\partial e_n}{\partial \phi} \right. \\
 & \quad \left. + \left(\frac{\partial x_m}{\partial \phi} u_n + \frac{\partial u_m}{\partial \phi} (x_n + u_n) \right) e_m \cdot \frac{\partial e'_n}{\partial r} \right) = 2drd\phi \left(\frac{\partial u_m}{\partial r} \frac{\partial u_m}{\partial \phi} \right. \\
 & \quad \left. + \frac{\partial u_r}{\partial \phi} + u_n \hat{\mathbf{r}} \cdot \frac{\partial e_n}{\partial \phi} + \frac{\partial u_m}{\partial r} (x_n + u_n) e_m \cdot \frac{\partial e_n}{\partial \phi} \right) \\
 & = 2drd\phi \left(\frac{\partial u_m}{\partial r} \frac{\partial u_m}{\partial \phi} + \frac{\partial u_r}{\partial \phi} - u_\phi + \frac{\partial u_r}{\partial r} (x_n + u_n) \hat{\mathbf{r}} \cdot \frac{\partial e_n}{\partial \phi} \right. \\
 & \quad \left. + \frac{\partial u_\phi}{\partial r} (x_n + u_n) \hat{\boldsymbol{\phi}} \cdot \frac{\partial e_n}{\partial \phi} \right) \\
 & = 2drd\phi \left(\frac{\partial u_m}{\partial r} \frac{\partial u_m}{\partial \phi} + \frac{\partial u_r}{\partial \phi} - u_\phi - \frac{\partial u_r}{\partial r} u_\phi + \frac{\partial u_\phi}{\partial r} (r + u_r) \right).
 \end{aligned}$$

Finally for the z, ϕ term we have

$$\begin{aligned}
 & 2dzd\phi \left(\frac{\partial u_m}{\partial z} \frac{\partial u_m}{\partial \phi} + \frac{\partial u_m}{\partial z} \frac{\partial x'_m}{\partial \phi} + \frac{\partial u_m}{\partial \phi} \frac{\partial x_m}{\partial z} \right. \\
 & \quad \left. + \frac{1}{2} (u_m u_n + x_m u_n + u_m x_n) \left(\frac{\partial e'_m}{\partial z} \cdot \frac{\partial e_n}{\partial \phi} + \frac{\partial e_m}{\partial \phi} \cdot \frac{\partial e'_n}{\partial z} \right) \right) \\
 & \quad + 2d\phi dz \left(\left(\frac{\partial x_m}{\partial z} u_n + \frac{\partial u_m}{\partial z} (x_n + u_n) \right) e_m \cdot \frac{\partial e_n}{\partial \phi} \right. \\
 & \quad \left. + \left(\frac{\partial x_m}{\partial \phi} u_n + \frac{\partial u_m}{\partial \phi} (x_n + u_n) \right) e_m \cdot \frac{\partial e'_n}{\partial z} \right) = 2dzd\phi \left(\frac{\partial u_m}{\partial z} \frac{\partial u_m}{\partial \phi} \right. \\
 & \quad \left. + \frac{\partial u_m}{\partial \phi} \frac{\partial x_m}{\partial z} + u_n \hat{\mathbf{z}} \cdot \frac{\partial e_n}{\partial \phi} + \frac{\partial u_m}{\partial z} (x_n + u_n) e_m \cdot \frac{\partial e_n}{\partial \phi} \right) \\
 & = 2dzd\phi \left(\frac{\partial u_m}{\partial z} \frac{\partial u_m}{\partial \phi} + \frac{\partial u_z}{\partial \phi} - \frac{\partial u_r}{\partial z} u_\phi + \frac{\partial u_\phi}{\partial z} (r + u_r) \right).
 \end{aligned}$$

To summarize we have, including both first and second order terms,

$$\begin{aligned}
 d\mathbf{l}^2 - d\mathbf{x}^2 = & 2drdr \left(\frac{1}{2} \frac{\partial u_m}{\partial r} \frac{\partial u_m}{\partial r} + \frac{\partial u_r}{\partial r} \right) + 2r^2 d\phi d\phi \left(\frac{1}{2r^2} \frac{\partial u_m}{\partial \phi} \frac{\partial u_m}{\partial \phi} \right. \\
 & \left. + \frac{1}{2r^2} \left(u_r^2 + u_\phi^2 \right) + \frac{u_r}{r} - \frac{1}{r} \frac{\partial u_r}{\partial \phi} \frac{u_\phi}{r} + \frac{1}{r} \frac{\partial u_\phi}{\partial \phi} \left(1 + \frac{u_r}{r} \right) \right) \\
 & + 2dzdz \left(\frac{1}{2} \frac{\partial u_m}{\partial z} \frac{\partial u_m}{\partial z} + \frac{\partial u_z}{\partial z} \right) + 2dr rd\phi \left(\frac{\partial u_m}{\partial r} \frac{1}{r} \frac{\partial u_m}{\partial \phi} \right. \\
 & \left. + \frac{1}{r} \frac{\partial u_r}{\partial \phi} - \frac{u_\phi}{r} - \frac{\partial u_r}{\partial r} \frac{u_\phi}{r} + \frac{\partial u_\phi}{\partial r} \left(1 + \frac{u_r}{r} \right) \right) \\
 & + 2rd\phi dz \left(\frac{\partial u_m}{\partial z} \frac{1}{r} \frac{\partial u_m}{\partial \phi} + \frac{1}{r} \frac{\partial u_z}{\partial \phi} - \frac{\partial u_r}{\partial z} \frac{u_\phi}{r} + \frac{\partial u_\phi}{\partial z} \left(1 + \frac{u_r}{r} \right) \right) \\
 & + 2dzdr \left(\frac{\partial u_m}{\partial z} \frac{\partial u_m}{\partial r} + \frac{\partial u_r}{\partial z} + \frac{\partial u_z}{\partial r} \right).
 \end{aligned} \tag{A.30}$$

Factors of r have been pulled out so that the portions remaining in the braces are exactly the cylindrical tensor elements as given in the text (except also with the second order terms here). Observe that the pre-calculation of the general formula has allowed an on paper expansion of the cylindrical tensor without too much pain, and this time without requiring Mathematica.

A.5 SPHERICAL TENSOR.

To perform the derivation in spherical coordinates we have some setup to do first, since we need explicit representations of all three unit vectors. The radial vector we can get easily by geometry and find the usual

$$\hat{\mathbf{r}} = \begin{bmatrix} \sin \theta \cos \phi \\ \sin \theta \sin \phi \\ \cos \theta \end{bmatrix}. \tag{A.31}$$

We can get $\hat{\phi}$ by geometrical intuition since it the plane unit vector at angle ϕ rotated by $\pi/2$. That is

$$\hat{\phi} = \begin{bmatrix} -\sin \phi \\ \cos \phi \\ 0 \end{bmatrix}. \quad (\text{A.32})$$

We can get $\hat{\theta}$ by utilizing the right handedness of the coordinates since

$$\hat{\phi} \times \hat{r} = \hat{\theta}, \quad (\text{A.33})$$

and find

$$\hat{\theta} = \begin{bmatrix} \cos \theta \cos \phi \\ \cos \theta \sin \phi \\ -\sin \theta \end{bmatrix}. \quad (\text{A.34})$$

Brute forcing the differential strain element calculation ([strainTensorSphericalColumnVectors.cdf](#)), we find

$$\begin{aligned}
 d\mathbf{l}^2 - d\mathbf{x}^2 = & 2(dr)^2 \left(\frac{\partial u_r}{\partial r} + \frac{1}{2} \frac{\partial u_m}{\partial r} \frac{\partial u_m}{\partial r} \right) + 2r^2(d\theta)^2 \left(\frac{1}{r} u_r + \frac{1}{2r^2} (u_r^2 + u_\theta^2) \right. \\
 & \left. - \frac{1}{r^2} u_\theta \frac{\partial u_r}{\partial \theta} + \left(\frac{1}{r} + \frac{1}{r^2} u_r \right) \frac{\partial u_\theta}{\partial \theta} + \frac{1}{2r^2} \frac{\partial u_m}{\partial \theta} \frac{\partial u_m}{\partial \theta} \right) \\
 & + 2r^2 \sin^2 \theta (d\phi)^2 \left(\frac{1}{2r^2 \sin^2 \theta} u_\phi^2 + \frac{1}{2r^2} u_\theta^2 \cot^2 \theta + \frac{1}{r} u_r \right. \\
 & \left. + \frac{1}{2r^2} u_r^2 + \left(\frac{1}{r} + \frac{1}{r^2} u_r \right) u_\theta \cot \theta - \frac{1}{r^2 \sin \theta} u_\phi \frac{\partial u_r}{\partial \phi} \right. \\
 & \left. - \frac{1}{r^2} u_\phi \frac{\cos \theta}{\sin^2 \theta} \frac{\partial u_\theta}{\partial \phi} + \frac{1}{r^2} \frac{\partial u_\phi}{\partial \phi} \left(u_\theta \frac{\cos \theta}{\sin^2 \theta} + (r + u_r) \frac{1}{\sin \theta} \right) \right. \\
 & \left. + \frac{1}{2r^2 \sin^2 \theta} \frac{\partial u_m}{\partial \phi} \frac{\partial u_m}{\partial \phi} \right) + 2dr r d\theta \left(-\frac{1}{r} u_\theta + \frac{1}{r} \frac{\partial u_r}{\partial \theta} \right. \\
 & \left. - \frac{1}{r} u_\theta \frac{\partial u_r}{\partial r} + \frac{\partial u_\theta}{\partial r} \left(1 + \frac{u_r}{r} \right) + \frac{1}{r} \frac{\partial u_m}{\partial r} \frac{\partial u_m}{\partial \theta} \right) \\
 & + 2r^2 \sin \theta d\theta d\phi \left(\frac{1}{r^2} u_\theta u_\phi - \frac{1}{r^2 \sin \theta} u_\theta \frac{\partial u_r}{\partial \phi} - \frac{1}{r^2} u_\phi \frac{\partial u_r}{\partial \theta} \right. \\
 & \left. - \frac{1}{r^2} u_\phi \cot \theta \left(r + u_r + \frac{\partial u_\theta}{\partial \theta} \right) + \frac{1}{r^2 \sin \theta} (r + u_r) \frac{\partial u_\theta}{\partial \phi} \right. \\
 & \left. + \frac{\partial u_\phi}{\partial \theta} \left(\frac{u_\theta}{r^2} \cot \theta + \frac{1}{r} + \frac{u_r}{r^2} \right) + \frac{1}{r^2 \sin \theta} \frac{\partial u_m}{\partial \theta} \frac{\partial u_m}{\partial \phi} \right) \\
 & + 2r \sin \theta d\phi dr \left(-\frac{1}{r} u_\phi + \frac{1}{r \sin \theta} \frac{\partial u_r}{\partial \phi} - u_\phi \frac{1}{r} \frac{\partial u_r}{\partial r} \right. \\
 & \left. - u_\phi \cot \theta \frac{1}{r} \frac{\partial u_\theta}{\partial r} + \frac{1}{r} \frac{\partial u_\phi}{\partial r} (u_\theta \cot \theta + r + u_r) \right. \\
 & \left. + \frac{1}{r \sin \theta} \frac{\partial u_m}{\partial \phi} \frac{\partial u_m}{\partial r} \right). \tag{A.35}
 \end{aligned}$$

A.6 SPHERICAL TENSOR. MANUAL DERIVATION.

Doing the calculation pretty much completely with Mathematica is rather unsatisfying. To set up for it let us first compute the unit vectors from scratch. I will use geometric algebra to do this calculation. Consider fig. [A.1](#) We have two sets of rotations, the

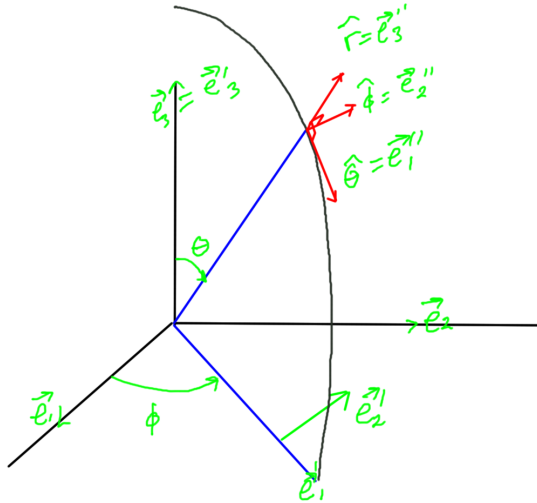

Figure A.1: Composite rotations for spherical polar unit vectors.

first is a rotation about the z axis by ϕ . Writing $i = \mathbf{e}_1\mathbf{e}_2$ for the unit bivector in the x, y plane, we rotate

$$\begin{aligned}\mathbf{e}'_1 &= \mathbf{e}_1 e^{i\phi} = \mathbf{e}_1 \cos \phi + \mathbf{e}_2 \sin \phi \\ \mathbf{e}'_2 &= \mathbf{e}_2 e^{i\phi} = \mathbf{e}_2 \cos \phi - \mathbf{e}_1 \sin \phi \\ \mathbf{e}'_3 &= \mathbf{e}_3.\end{aligned}\tag{A.36}$$

Now we rotate in the plane spanned by \mathbf{e}_3 and \mathbf{e}'_1 by θ . With $j = \mathbf{e}_3\mathbf{e}'_1$, our vectors in the plane rotate as

$$\begin{aligned}\mathbf{e}''_1 &= \mathbf{e}'_1 e^{j\theta} = \mathbf{e}_1 e^{i\phi} e^{j\theta} \\ \mathbf{e}''_3 &= \mathbf{e}'_3 e^{j\theta} = \mathbf{e}_3 e^{j\theta},\end{aligned}\tag{A.37}$$

(with $\mathbf{e}''_2 = \mathbf{e}_2$ since $\mathbf{e}_2 \cdot j = 0$).

$$\begin{aligned}\hat{\theta} &= \mathbf{e}''_1 = \mathbf{e}_1 e^{i\phi} e^{j\theta} \\ &= \mathbf{e}_1 e^{i\phi} (\cos \theta + \mathbf{e}_3 \mathbf{e}_1 e^{i\phi} \sin \theta) \\ &= \mathbf{e}_1 e^{i\phi} \cos \theta - \mathbf{e}_3 \sin \theta \\ &= (\mathbf{e}_1 \cos \phi + \mathbf{e}_2 \sin \phi) \cos \theta - \mathbf{e}_3 \sin \theta,\end{aligned}\tag{A.38}$$

$$\begin{aligned}
\hat{\mathbf{r}} &= \mathbf{e}_3'' = \mathbf{e}_3 e^{i\theta} \\
&= \mathbf{e}_3(\cos \theta + \mathbf{e}_3 \mathbf{e}_1 e^{i\phi} \sin \theta) \\
&= \mathbf{e}_3 \cos \theta + \mathbf{e}_1 e^{i\phi} \sin \theta \\
&= \mathbf{e}_3 \cos \theta + (\mathbf{e}_1 \cos \phi + \mathbf{e}_2 \sin \phi) \sin \theta.
\end{aligned} \tag{A.39}$$

Now, these are all the same relations that we could find with coordinate algebra

$$\begin{aligned}
\hat{\mathbf{r}} &= \mathbf{e}_1 \cos \phi \sin \theta + \mathbf{e}_2 \sin \phi \sin \theta + \mathbf{e}_3 \cos \theta \\
\hat{\boldsymbol{\theta}} &= \mathbf{e}_1 \cos \phi \cos \theta + \mathbf{e}_2 \sin \phi \cos \theta - \mathbf{e}_3 \sin \theta \\
\hat{\boldsymbol{\phi}} &= -\mathbf{e}_1 \sin \phi + \mathbf{e}_2 \cos \phi.
\end{aligned} \tag{A.40}$$

There is nothing special in this approach if that is as far as we go, but we can put things in a nice tidy form for computation of the differentials of the unit vectors. Introducing the unit pseudoscalar $I = \mathbf{e}_1 \mathbf{e}_2 \mathbf{e}_3$ we can write these in a compact exponential form.

$$\begin{aligned}
\hat{\mathbf{r}} &= (\mathbf{e}_1 \cos \phi + \mathbf{e}_2 \sin \phi) \sin \theta + \mathbf{e}_3 \cos \theta \\
&= \mathbf{e}_1 e^{i\phi} \sin \theta + \mathbf{e}_3 \cos \theta \\
&= \mathbf{e}_3(\cos \theta + \mathbf{e}_3 \mathbf{e}_1 e^{i\phi} \sin \theta) \\
&= \mathbf{e}_3(\cos \theta + \mathbf{e}_3 \mathbf{e}_1 \mathbf{e}_2 \mathbf{e}_2 e^{i\phi} \sin \theta) \\
&= \mathbf{e}_3(\cos \theta + I \hat{\boldsymbol{\phi}} \sin \theta) \\
&= \mathbf{e}_3 e^{I \hat{\boldsymbol{\phi}} \theta},
\end{aligned} \tag{A.41}$$

$$\begin{aligned}
\hat{\boldsymbol{\theta}} &= \mathbf{e}_1 \cos \phi \cos \theta + \mathbf{e}_2 \sin \phi \cos \theta - \mathbf{e}_3 \sin \theta \\
&= (\mathbf{e}_1 \cos \phi + \mathbf{e}_2 \sin \phi) \cos \theta - \mathbf{e}_3 \sin \theta \\
&= \mathbf{e}_1 e^{i\phi} \cos \theta - \mathbf{e}_3 \sin \theta \\
&= \mathbf{e}_1 e^{i\phi} (\cos \theta - e^{-i\phi} \mathbf{e}_1 \mathbf{e}_3 \sin \theta) \\
&= \mathbf{e}_1 e^{i\phi} (\cos \theta - \mathbf{e}_1 \mathbf{e}_3 e^{i\phi} \sin \theta) \\
&= \mathbf{e}_1 e^{i\phi} (\cos \theta - \mathbf{e}_1 \mathbf{e}_3 \mathbf{e}_2 \mathbf{e}_2 e^{i\phi} \sin \theta) \\
&= \mathbf{e}_1 e^{i\phi} (\cos \theta + I \hat{\boldsymbol{\phi}} \sin \theta) \\
&= \mathbf{e}_1 \mathbf{e}_2 \mathbf{e}_2 e^{i\phi} (\cos \theta + I \hat{\boldsymbol{\phi}} \sin \theta) \\
&= i \hat{\boldsymbol{\phi}} e^{I \hat{\boldsymbol{\phi}} \theta}.
\end{aligned} \tag{A.42}$$

To summarize we have

$$\begin{aligned}
 \hat{\phi} &= \mathbf{e}_2 e^{i\phi} \\
 \hat{\mathbf{r}} &= \mathbf{e}_3 e^{I\hat{\phi}\theta} \\
 \hat{\theta} &= i\hat{\phi} e^{I\hat{\phi}\theta}.
 \end{aligned} \tag{A.43}$$

Taking differentials we find first

$$d\hat{\phi} = \mathbf{e}_2 e^{i\phi} i d\phi = \hat{\phi} i d\phi, \tag{A.44}$$

$$\begin{aligned}
 d\hat{\theta} &= d \left(i\hat{\phi} e^{I\hat{\phi}\theta} \right) \\
 &= i d\hat{\phi} e^{I\hat{\phi}\theta} + i\hat{\phi} d \left(\cos \theta + I\hat{\phi} \sin \theta \right) \\
 &= i d\hat{\phi} e^{I\hat{\phi}\theta} + i\hat{\phi} I (d\hat{\phi}) \sin \theta + i\hat{\phi} I \hat{\phi} e^{I\hat{\phi}\theta} d\theta \\
 &= i\hat{\phi} i e^{I\hat{\phi}\theta} d\phi + i\hat{\phi} I \hat{\phi} i \sin \theta d\phi + i\hat{\phi} I \hat{\phi} e^{I\hat{\phi}\theta} d\theta \\
 &= \hat{\phi} e^{I\hat{\phi}\theta} d\phi - I \sin \theta d\phi - \mathbf{e}_3 e^{I\hat{\phi}\theta} d\theta \\
 &= \hat{\phi} (\cos \theta + I\hat{\phi} \sin \theta) d\phi - I \sin \theta d\phi - \mathbf{e}_3 e^{I\hat{\phi}\theta} d\theta \\
 &= \hat{\phi} \cos \theta d\phi - \hat{\mathbf{r}} d\theta,
 \end{aligned} \tag{A.45}$$

$$\begin{aligned}
 d\hat{\mathbf{r}} &= \mathbf{e}_3 d \left(e^{I\hat{\phi}\theta} \right) \\
 &= \mathbf{e}_3 d \left(\cos \theta + I\hat{\phi} \sin \theta \right) \\
 &= \mathbf{e}_3 \left(I (d\hat{\phi}) \sin \theta + I\hat{\phi} e^{I\hat{\phi}\theta} d\theta \right) \\
 &= \mathbf{e}_3 \left(I\hat{\phi} i \sin \theta d\phi + I\hat{\phi} e^{I\hat{\phi}\theta} d\theta \right) \\
 &= i\hat{\phi} i \sin \theta d\phi + i\hat{\phi} e^{I\hat{\phi}\theta} d\theta \\
 &= \hat{\phi} \sin \theta d\phi + \hat{\theta} d\theta.
 \end{aligned} \tag{A.46}$$

Summarizing these differentials we have

$$\begin{aligned}
 d\hat{\mathbf{r}} &= \hat{\phi} \sin \theta d\phi + \hat{\theta} d\theta \\
 d\hat{\theta} &= \hat{\phi} \cos \theta d\phi - \hat{\mathbf{r}} d\theta \\
 d\hat{\phi} &= \hat{\phi} i d\phi.
 \end{aligned} \tag{A.47}$$

A final cleanup is required. While $\hat{\phi}i$ is a vector and has a nicely compact form, we need to decompose this into components in the $\hat{\mathbf{r}}$, $\hat{\theta}$ and $\hat{\phi}$ directions. Taking scalar products we have

$$\hat{\phi} \cdot (\hat{\phi}i) = 0, \tag{A.48}$$

$$\begin{aligned}
 \hat{\mathbf{r}} \cdot (\hat{\boldsymbol{\phi}}i) &= \langle \hat{\mathbf{r}}\hat{\boldsymbol{\phi}}i \rangle \\
 &= \langle \mathbf{e}_3 e^{I\hat{\boldsymbol{\phi}}\theta} \mathbf{e}_2 e^{i\phi} i \rangle \\
 &= \langle \mathbf{e}_3 (\cos \theta + I \mathbf{e}_2 e^{i\phi} \sin \theta) \mathbf{e}_2 e^{i\phi} i \rangle \\
 &= \langle I (\cos \theta e^{-i\phi} + I \mathbf{e}_2 \sin \theta) \mathbf{e}_2 \rangle \\
 &= -\sin \theta,
 \end{aligned} \tag{A.49}$$

$$\begin{aligned}
 \hat{\boldsymbol{\theta}} \cdot (\hat{\boldsymbol{\phi}}i) &= \langle \hat{\boldsymbol{\theta}}\hat{\boldsymbol{\phi}}i \rangle \\
 &= \langle i\hat{\boldsymbol{\phi}} e^{I\hat{\boldsymbol{\phi}}\theta} \hat{\boldsymbol{\phi}}i \rangle \\
 &= -\langle \hat{\boldsymbol{\phi}} e^{I\hat{\boldsymbol{\phi}}\theta} \hat{\boldsymbol{\phi}} \rangle \\
 &= -\langle e^{I\hat{\boldsymbol{\phi}}\theta} \rangle \\
 &= -\cos \theta.
 \end{aligned} \tag{A.50}$$

Summarizing once again, but this time in terms of $\hat{\mathbf{r}}$, $\hat{\boldsymbol{\theta}}$ and $\hat{\boldsymbol{\phi}}$ we have

$$\begin{aligned}
 d\hat{\mathbf{r}} &= \hat{\boldsymbol{\phi}} \sin \theta d\phi + \hat{\boldsymbol{\theta}} d\theta \\
 d\hat{\boldsymbol{\theta}} &= \hat{\boldsymbol{\phi}} \cos \theta d\phi - \hat{\mathbf{r}} d\theta \\
 d\hat{\boldsymbol{\phi}} &= -(\hat{\mathbf{r}} \sin \theta + \hat{\boldsymbol{\theta}} \cos \theta) d\phi.
 \end{aligned} \tag{A.51}$$

Now we are set to take differentials. With

$$\mathbf{x} = r\hat{\mathbf{r}}, \tag{A.52}$$

we have

$$d\mathbf{x} = dr\hat{\mathbf{r}} + r d\hat{\mathbf{r}} = dr\hat{\mathbf{r}} + \hat{\boldsymbol{\phi}} r \sin \theta d\phi + r\hat{\boldsymbol{\theta}} d\theta. \tag{A.53}$$

Squaring this we get the usual spherical polar line scalar line element

$$d\mathbf{x}^2 = dr^2 + r^2 \sin^2 \theta d\phi^2 + r^2 d\theta^2. \tag{A.54}$$

With

$$\mathbf{u} = u_r \hat{\mathbf{r}} + u_\theta \hat{\boldsymbol{\theta}} + u_\phi \hat{\boldsymbol{\phi}}, \tag{A.55}$$

our differential is

$$\begin{aligned}
 d\mathbf{u} &= du_r \hat{\mathbf{r}} + du_\theta \hat{\boldsymbol{\theta}} + du_\phi \hat{\boldsymbol{\phi}} + u_r d\hat{\mathbf{r}} + u_\theta d\hat{\boldsymbol{\theta}} + u_\phi d\hat{\boldsymbol{\phi}} \\
 &= du_r \hat{\mathbf{r}} + du_\theta \hat{\boldsymbol{\theta}} + du_\phi \hat{\boldsymbol{\phi}} + u_r (\hat{\boldsymbol{\phi}} \sin \theta d\phi + \hat{\boldsymbol{\theta}} d\theta) \\
 &\quad + u_\theta (\hat{\boldsymbol{\phi}} \cos \theta d\phi - \hat{\mathbf{r}} d\theta) - u_\phi (\hat{\mathbf{r}} \sin \theta + \hat{\boldsymbol{\theta}} \cos \theta) d\phi \\
 &= \hat{\mathbf{r}} (du_r - u_\theta d\theta - u_\phi \sin \theta d\phi) \\
 &\quad + \hat{\boldsymbol{\theta}} (du_\theta + u_r d\theta - u_\phi \cos \theta d\phi) \\
 &\quad + \hat{\boldsymbol{\phi}} (du_\phi + u_r \sin \theta d\phi + u_\theta \cos \theta d\phi).
 \end{aligned} \tag{A.56}$$

We can add $d\mathbf{x}$ to this and take differences

$$\begin{aligned}
 (d\mathbf{u} + d\mathbf{x})^2 - d\mathbf{x}^2 &= (du_r - u_\theta d\theta - u_\phi \sin \theta d\phi + dr)^2 \\
 &\quad + (du_\theta + u_r d\theta - u_\phi \cos \theta d\phi + rd\theta)^2 \\
 &\quad + (du_\phi + u_r \sin \theta d\phi + u_\theta \cos \theta d\phi + r \sin \theta d\phi)^2.
 \end{aligned} \tag{A.57}$$

For each $m = r, \theta, \phi$ we have

$$du_m = \frac{\partial u_m}{\partial r} dr + \frac{\partial u_m}{\partial \theta} d\theta + \frac{\partial u_m}{\partial \phi} d\phi, \tag{A.58}$$

and plugging through that calculation is really all it takes to derive the textbook result. To do this to first order in u_m , we find

$$\begin{aligned}
 &\frac{1}{2} ((d\mathbf{u} + d\mathbf{x})^2 - d\mathbf{x}^2) \\
 &= du_r dr - u_\theta d\theta dr - u_\phi \sin \theta d\phi dr \\
 &\quad + du_\theta rd\theta + u_r rd\theta^2 - u_\phi r \cos \theta d\phi d\theta \\
 &\quad + r \sin \theta du_\phi d\phi + r \sin^2 \theta u_r d\phi^2 + r \sin \theta \cos \theta u_\theta d\phi^2 \\
 &= \left(\frac{\partial u_r}{\partial r} dr + \frac{\partial u_r}{\partial \theta} d\theta + \frac{\partial u_r}{\partial \phi} d\phi \right) dr - u_\theta d\theta dr - u_\phi \sin \theta d\phi dr \\
 &\quad + \left(\frac{\partial u_\theta}{\partial r} dr + \frac{\partial u_\theta}{\partial \theta} d\theta + \frac{\partial u_\theta}{\partial \phi} d\phi \right) rd\theta + u_r rd\theta^2 - u_\phi r \cos \theta d\phi d\theta \\
 &\quad + \left(\frac{\partial u_\phi}{\partial r} dr + \frac{\partial u_\phi}{\partial \theta} d\theta + \frac{\partial u_\phi}{\partial \phi} d\phi \right) r \sin \theta d\phi + r \sin^2 \theta u_r d\phi^2 \\
 &\quad + r \sin \theta \cos \theta u_\theta d\phi^2.
 \end{aligned} \tag{A.59}$$

Collecting terms we have the result of the text in the braces

$$\begin{aligned}
 ((d\mathbf{u} + d\mathbf{x})^2 - d\mathbf{x}^2) = & 2dr^2 \left(\frac{\partial u_r}{\partial r} \right) + 2r^2 d\theta^2 \left(\frac{1}{r} \frac{\partial u_\theta}{\partial \theta} + u_r \frac{1}{r} \right) \\
 & + 2r^2 \sin^2 \theta d\phi^2 \left(\frac{\partial u_\phi}{\partial \phi} \frac{1}{r \sin \theta} + \frac{1}{r} u_r + \frac{1}{r} \cot \theta u_\theta \right) \\
 & + 2drrd\theta \left(\frac{1}{r} \frac{\partial u_r}{\partial \theta} - \frac{1}{r} u_\theta + \frac{\partial u_\theta}{\partial r} \right) \\
 & + 2r^2 \sin \theta d\theta d\phi \left(\frac{\partial u_\theta}{\partial \phi} \frac{1}{r \sin \theta} - \frac{1}{r} u_\phi \cot \theta \right. \\
 & \qquad \qquad \qquad \left. + \frac{1}{r} \frac{\partial u_\phi}{\partial \theta} \right) \\
 & + 2r \sin \theta d\phi dr \left(\frac{1}{r \sin \theta} \frac{\partial u_r}{\partial \phi} - \frac{1}{r} u_\phi + \frac{\partial u_\phi}{\partial r} \right).
 \end{aligned}
 \tag{A.60}$$

It should be possible to do the calculation to second order too, but to include all the quadratic terms in u_m is again really messy. Trying that with Mathematica ([strainTensorSpherical.cdf](#)) gives the same results as above using the strictly coordinate algebra approach.

B

GEOMETRIC STRAIN AND TRACTION.

B.1 MOTIVATION.

Exercise 6.1 from [2] is to show that the traction vector can be written in vector form (a rather curious thing to have to say) as

$$\mathbf{t} = -p\hat{\mathbf{n}} + \mu(2(\hat{\mathbf{n}} \cdot \nabla)\mathbf{u} + \hat{\mathbf{n}} \times (\nabla \times \mathbf{u})). \quad (\text{B.1})$$

Note that the text uses a wedge symbol for the cross product, and I have switched to standard notation. I have done so because the use of a Geometric-Algebra wedge product also can be used to express this relationship, in which case we would write

$$\mathbf{t} = -p\hat{\mathbf{n}} + \mu(2(\hat{\mathbf{n}} \cdot \nabla)\mathbf{u} + (\nabla \wedge \mathbf{u}) \cdot \hat{\mathbf{n}}). \quad (\text{B.2})$$

In either case we have

$$(\nabla \wedge \mathbf{u}) \cdot \hat{\mathbf{n}} = \hat{\mathbf{n}} \times (\nabla \times \mathbf{u}) = \nabla'(\hat{\mathbf{n}} \cdot \mathbf{u}') - (\hat{\mathbf{n}} \cdot \nabla)\mathbf{u}, \quad (\text{B.3})$$

(where the primes indicate the scope of the gradient, showing here that we are operating only on \mathbf{u} , and not $\hat{\mathbf{n}}$). After computing this, lets also compute the stress tensor in cylindrical and spherical coordinates (a portion of that is also problem 6.10), something that this allows us to do fairly easily without having to deal with the second order terms that we encountered doing this by computing the difference of squared displacements. We will work primarily with just the strain tensor portion of the traction vector expressions above, calculating

$$2\mathbf{e}_{\hat{\mathbf{n}}} = 2(\hat{\mathbf{n}} \cdot \nabla)\mathbf{u} + \hat{\mathbf{n}} \times (\nabla \times \mathbf{u}) = 2(\hat{\mathbf{n}} \cdot \nabla)\mathbf{u} + (\nabla \wedge \mathbf{u}) \cdot \hat{\mathbf{n}}. \quad (\text{B.4})$$

We will see that this gives us a nice way to interpret these tensor relationships. The interpretation was less clear when we computed this from the second order difference method, but here we see that we are just looking at the components of the force in each of the respective directions, dependent on which way our normal is specified.

B.2 VERIFYING THE RELATIONSHIP.

Let us start with the the plain old cross product version

$$\begin{aligned}
 (\hat{\mathbf{n}} \times (\nabla \times \mathbf{u}) + 2(\hat{\mathbf{n}} \cdot \nabla)\mathbf{u})_i &= n_a (\nabla \times \mathbf{u})_b \epsilon_{abi} + 2n_a \partial_a u_i \\
 &= n_a \partial_r u_s \epsilon_{rsb} \epsilon_{abi} + 2n_a \partial_a u_i \\
 &= n_a \partial_r u_s \delta_{ia}^{[rs]} + 2n_a \partial_a u_i \\
 &= n_a (\partial_i u_a - \partial_a u_i) + 2n_a \partial_a u_i \quad (\text{B.5}) \\
 &= n_a \partial_i u_a + n_a \partial_a u_i \\
 &= n_a (\partial_i u_a + \partial_a u_i) \\
 &= \sigma_{ia} n_a.
 \end{aligned}$$

We can also put the double cross product in wedge product form

$$\begin{aligned}
 \hat{\mathbf{n}} \times (\nabla \times \mathbf{u}) &= -I \hat{\mathbf{n}} \wedge (\nabla \times \mathbf{u}) \\
 &= -\frac{I}{2} (\hat{\mathbf{n}} (\nabla \times \mathbf{u}) - (\nabla \times \mathbf{u}) \hat{\mathbf{n}}) \\
 &= -\frac{I}{2} (-I \hat{\mathbf{n}} (\nabla \wedge \mathbf{u}) + I (\nabla \wedge \mathbf{u}) \hat{\mathbf{n}}) \quad (\text{B.6}) \\
 &= -\frac{I^2}{2} (-\hat{\mathbf{n}} (\nabla \wedge \mathbf{u}) + (\nabla \wedge \mathbf{u}) \hat{\mathbf{n}}) \\
 &= (\nabla \wedge \mathbf{u}) \cdot \hat{\mathbf{n}}.
 \end{aligned}$$

Equivalently (and easier) we can just expand the dot product of the wedge and the vector using the relationship

$$\mathbf{a} \cdot (\mathbf{c} \wedge \mathbf{d} \wedge \mathbf{e} \wedge \dots) = (\mathbf{a} \cdot \mathbf{c})(\mathbf{d} \wedge \mathbf{e} \wedge \dots) - (\mathbf{a} \cdot \mathbf{d})(\mathbf{c} \wedge \mathbf{e} \wedge \dots), \quad (\text{B.7})$$

so we find

$$\begin{aligned}
 ((\nabla \wedge \mathbf{u}) \cdot \hat{\mathbf{n}} + 2(\hat{\mathbf{n}} \cdot \nabla)\mathbf{u})_i &= (\nabla'(\mathbf{u}' \cdot \hat{\mathbf{n}}) - (\hat{\mathbf{n}} \cdot \nabla)\mathbf{u} + 2(\hat{\mathbf{n}} \cdot \nabla)\mathbf{u})_i \\
 &= \partial_i u_a n_a + n_a \partial_a u_i \\
 &= \sigma_{ia} n_a.
 \end{aligned} \quad (\text{B.8})$$

B.3 CYLINDRICAL STRAIN TENSOR.

Let us now compute the strain tensor (and implicitly the traction vector) in cylindrical coordinates. Our gradient in cylindrical coordinates is the familiar

$$\nabla = \hat{\mathbf{r}} \frac{\partial}{\partial r} + \hat{\boldsymbol{\phi}} \frac{1}{r} \frac{\partial}{\partial \phi} + \hat{\mathbf{z}} \frac{\partial}{\partial z}, \quad (\text{B.9})$$

and our cylindrical velocity is

$$\mathbf{u} = \hat{\mathbf{r}} u_r + \hat{\boldsymbol{\phi}} u_\phi + \hat{\mathbf{z}} u_z. \quad (\text{B.10})$$

Our curl is then

$$\begin{aligned} \nabla \wedge \mathbf{u} &= \left(\hat{\mathbf{r}} \frac{\partial}{\partial r} + \hat{\boldsymbol{\phi}} \frac{1}{r} \frac{\partial}{\partial \phi} + \hat{\mathbf{z}} \frac{\partial}{\partial z} \right) \wedge (\hat{\mathbf{r}} u_r + \hat{\boldsymbol{\phi}} u_\phi + \hat{\mathbf{z}} u_z) \\ &= \hat{\mathbf{r}} \wedge \hat{\boldsymbol{\phi}} \left(\partial_r u_\phi - \frac{1}{r} \partial_\phi u_r \right) \\ &\quad + \hat{\boldsymbol{\phi}} \wedge \hat{\mathbf{z}} \left(\frac{1}{r} \partial_\phi u_z - \partial_z u_\phi \right) \\ &\quad + \hat{\mathbf{z}} \wedge \hat{\mathbf{r}} (\partial_z u_r - \partial_r u_z) \\ &\quad + \frac{1}{r} \hat{\boldsymbol{\phi}} \wedge ((\partial_\phi \hat{\mathbf{r}}) u_r + (\partial_\phi \hat{\boldsymbol{\phi}}) u_\phi). \end{aligned} \quad (\text{B.11})$$

Since $\partial_\phi \hat{\mathbf{r}} = \hat{\boldsymbol{\theta}}$ and $\partial_\phi \hat{\boldsymbol{\phi}} = -\hat{\mathbf{r}}$, we have only one cross term and our curl is

$$\begin{aligned} \nabla \wedge \mathbf{u} &= \hat{\mathbf{r}} \wedge \hat{\boldsymbol{\phi}} \left(\partial_r u_\phi - \frac{1}{r} \partial_\phi u_r + \frac{u_\phi}{r} \right) \\ &\quad + \hat{\boldsymbol{\phi}} \wedge \hat{\mathbf{z}} \left(\frac{1}{r} \partial_\phi u_z - \partial_z u_\phi \right) \\ &\quad + \hat{\mathbf{z}} \wedge \hat{\mathbf{r}} (\partial_z u_r - \partial_r u_z). \end{aligned} \quad (\text{B.12})$$

We can now move on to compute the directional derivatives and complete the strain calculation in cylindrical coordinates. Let us consider this computation of the stress for normals in each direction in term.

B.3.1 *Outwards radial normal* $\hat{\mathbf{n}} = \hat{\mathbf{r}}$.

Our directional derivative component for a $\hat{\mathbf{r}}$ normal direction does not have any cross terms

$$\begin{aligned} 2(\hat{\mathbf{r}} \cdot \nabla)\mathbf{u} &= 2\partial_r (\hat{\mathbf{r}}u_r + \hat{\boldsymbol{\phi}}u_\phi + \hat{\mathbf{z}}u_z) \\ &= 2 (\hat{\mathbf{r}}\partial_r u_r + \hat{\boldsymbol{\phi}}\partial_r u_\phi + \hat{\mathbf{z}}\partial_r u_z). \end{aligned} \quad (\text{B.13})$$

Projecting our curl bivector onto the $\hat{\mathbf{r}}$ direction we have

$$\begin{aligned} (\nabla \wedge \mathbf{u}) \cdot \hat{\mathbf{r}} &= (\hat{\mathbf{r}} \wedge \hat{\boldsymbol{\phi}}) \cdot \hat{\mathbf{r}} \left(\partial_r u_\phi - \frac{1}{r} \partial_\phi u_r + \frac{u_\phi}{r} \right) \\ &\quad + (\hat{\boldsymbol{\phi}} \wedge \hat{\mathbf{z}}) \cdot \hat{\mathbf{r}} \left(\frac{1}{r} \partial_\phi u_z - \partial_z u_\phi \right) \\ &\quad + (\hat{\mathbf{z}} \wedge \hat{\mathbf{r}}) \cdot \hat{\mathbf{r}} (\partial_z u_r - \partial_r u_z) \\ &= -\hat{\boldsymbol{\phi}} \left(\partial_r u_\phi - \frac{1}{r} \partial_\phi u_r + \frac{u_\phi}{r} \right) + \hat{\mathbf{z}} (\partial_z u_r - \partial_r u_z). \end{aligned} \quad (\text{B.14})$$

Putting things together we have

$$\begin{aligned} 2\mathbf{e}_{\hat{\mathbf{r}}} &= 2 (\hat{\mathbf{r}}\partial_r u_r + \hat{\boldsymbol{\phi}}\partial_r u_\phi + \hat{\mathbf{z}}\partial_r u_z) - \hat{\boldsymbol{\phi}} \left(\partial_r u_\phi - \frac{1}{r} \partial_\phi u_r + \frac{u_\phi}{r} \right) \\ &\quad + \hat{\mathbf{z}} (\partial_z u_r - \partial_r u_z) \\ &= \hat{\mathbf{r}} (2\partial_r u_r) + \hat{\boldsymbol{\phi}} \left(2\partial_r u_\phi - \partial_r u_\phi + \frac{1}{r} \partial_\phi u_r - \frac{u_\phi}{r} \right) \\ &\quad + \hat{\mathbf{z}} (2\partial_r u_z + \partial_z u_r - \partial_r u_z). \end{aligned} \quad (\text{B.15})$$

For our stress tensor

$$\boldsymbol{\sigma}_{\hat{\mathbf{r}}} = -p\hat{\mathbf{r}} + 2\mu\mathbf{e}_{\hat{\mathbf{r}}}, \quad (\text{B.16})$$

we can now read off our components by taking dot products to yield

$$\sigma_{rr} = -p + 2\mu \frac{\partial u_r}{\partial r}, \quad (\text{B.17a})$$

$$\sigma_{r\phi} = \mu \left(\frac{\partial u_\phi}{\partial r} + \frac{1}{r} \frac{\partial u_r}{\partial \phi} - \frac{u_\phi}{r} \right), \quad (\text{B.17b})$$

$$\sigma_{rz} = \mu \left(\frac{\partial u_z}{\partial r} + \frac{\partial u_r}{\partial z} \right). \quad (\text{B.17c})$$

B.3.2 *Azimuthal normal* $\hat{\mathbf{n}} = \hat{\boldsymbol{\phi}}$.

Our directional derivative component for a $\hat{\boldsymbol{\phi}}$ normal direction will have some cross terms since both $\hat{\mathbf{r}}$ and $\hat{\boldsymbol{\phi}}$ are functions of ϕ

$$\begin{aligned} 2(\hat{\boldsymbol{\phi}} \cdot \nabla)\mathbf{u} &= \frac{2}{r}\partial_\phi(\hat{\mathbf{r}}u_r + \hat{\boldsymbol{\phi}}u_\phi + \hat{\mathbf{z}}u_z) \\ &= \frac{2}{r}(\hat{\mathbf{r}}\partial_\phi u_r + \hat{\boldsymbol{\phi}}\partial_\phi u_\phi + \hat{\mathbf{z}}\partial_\phi u_z + (\partial_\phi \hat{\mathbf{r}})u_r + (\partial_\phi \hat{\boldsymbol{\phi}})u_\phi) \quad (\text{B.18}) \\ &= \frac{2}{r}(\hat{\mathbf{r}}(\partial_\phi u_r - u_\phi) + \hat{\boldsymbol{\phi}}(\partial_\phi u_\phi + u_r) + \hat{\mathbf{z}}\partial_\phi u_z) \end{aligned}$$

Projecting our curl bivector onto the $\hat{\boldsymbol{\phi}}$ direction we have

$$\begin{aligned} (\nabla \wedge \mathbf{u}) \cdot \hat{\boldsymbol{\phi}} &= (\hat{\mathbf{r}} \wedge \hat{\boldsymbol{\phi}}) \cdot \hat{\boldsymbol{\phi}} \left(\partial_r u_\phi - \frac{1}{r}\partial_\phi u_r + \frac{u_\phi}{r} \right) \\ &\quad + (\hat{\boldsymbol{\phi}} \wedge \hat{\mathbf{z}}) \cdot \hat{\boldsymbol{\phi}} \left(\frac{1}{r}\partial_\phi u_z - \partial_z u_\phi \right) \\ &\quad + (\hat{\mathbf{z}} \wedge \hat{\mathbf{r}}) \cdot \hat{\boldsymbol{\phi}} (\partial_z u_r - \partial_r u_z) \\ &= \hat{\mathbf{r}} \left(\partial_r u_\phi - \frac{1}{r}\partial_\phi u_r + \frac{u_\phi}{r} \right) - \hat{\mathbf{z}} \left(\frac{1}{r}\partial_\phi u_z - \partial_z u_\phi \right) \end{aligned} \quad (\text{B.19})$$

Putting things together we have

$$\begin{aligned} 2\mathbf{e}_{\hat{\boldsymbol{\phi}}} &= \frac{2}{r}(\hat{\mathbf{r}}(\partial_\phi u_r - u_\phi) + \hat{\boldsymbol{\phi}}(\partial_\phi u_\phi + u_r) + \hat{\mathbf{z}}\partial_\phi u_z) \\ &\quad + \hat{\mathbf{r}} \left(\partial_r u_\phi - \frac{1}{r}\partial_\phi u_r + \frac{u_\phi}{r} \right) \\ &\quad - \hat{\mathbf{z}} \left(\frac{1}{r}\partial_\phi u_z - \partial_z u_\phi \right) \\ &= \hat{\mathbf{r}} \left(\frac{1}{r}\partial_\phi u_r - \frac{u_\phi}{r} + \partial_r u_\phi \right) + \frac{2}{r}\hat{\boldsymbol{\phi}}(\partial_\phi u_\phi + u_r) + \hat{\mathbf{z}} \left(\frac{1}{r}\partial_\phi u_z + \partial_z u_\phi \right). \end{aligned} \quad (\text{B.20})$$

For our stress tensor

$$\boldsymbol{\sigma}_{\hat{\boldsymbol{\phi}}} = -p\hat{\boldsymbol{\phi}} + 2\mu\mathbf{e}_{\hat{\boldsymbol{\phi}}}, \quad (\text{B.21})$$

so we can now read off our components by taking dot products to yield

$$\sigma_{\phi\phi} = -p + 2\mu \left(\frac{1}{r}\frac{\partial u_\phi}{\partial \phi} + \frac{u_r}{r} \right), \quad (\text{B.22a})$$

$$\sigma_{\phi z} = \mu \left(\frac{1}{r} \frac{\partial u_z}{\partial \phi} + \frac{\partial u_\phi}{\partial z} \right), \quad (\text{B.22b})$$

$$\sigma_{\phi r} = \mu \left(\frac{1}{r} \frac{\partial u_r}{\partial \phi} - \frac{u_\phi}{r} + \frac{\partial u_\phi}{\partial r} \right). \quad (\text{B.22c})$$

B.3.3 Longitudinal normal $\hat{\mathbf{n}} = \hat{\mathbf{z}}$.

Like the $\hat{\mathbf{r}}$ normal direction, our directional derivative component for a $\hat{\mathbf{z}}$ normal direction will not have any cross terms

$$\begin{aligned} 2(\hat{\mathbf{z}} \cdot \nabla) \mathbf{u} &= \partial_z (\hat{\mathbf{r}} u_r + \hat{\boldsymbol{\phi}} u_\phi + \hat{\mathbf{z}} u_z) \\ &= \hat{\mathbf{r}} \partial_z u_r + \hat{\boldsymbol{\phi}} \partial_z u_\phi + \hat{\mathbf{z}} \partial_z u_z. \end{aligned} \quad (\text{B.23})$$

Projecting our curl bivector onto the $\hat{\mathbf{z}}$ direction we have

$$\begin{aligned} (\nabla \wedge \mathbf{u}) \cdot \hat{\boldsymbol{\phi}} &= (\hat{\mathbf{r}} \wedge \hat{\boldsymbol{\phi}}) \cdot \hat{\mathbf{z}} \left(\partial_r u_\phi - \frac{1}{r} \partial_\phi u_r + \frac{u_\phi}{r} \right) \\ &\quad + (\hat{\boldsymbol{\phi}} \wedge \hat{\mathbf{z}}) \cdot \hat{\mathbf{z}} \left(\frac{1}{r} \partial_\phi u_z - \partial_z u_\phi \right) \\ &\quad + (\hat{\mathbf{z}} \wedge \hat{\mathbf{r}}) \cdot \hat{\mathbf{z}} (\partial_z u_r - \partial_r u_z) \\ &= \hat{\boldsymbol{\phi}} \left(\frac{1}{r} \partial_\phi u_z - \partial_z u_\phi \right) - \hat{\mathbf{r}} (\partial_z u_r - \partial_r u_z). \end{aligned} \quad (\text{B.24})$$

Putting things together we have

$$\begin{aligned} 2\mathbf{e}_{\hat{\mathbf{z}}} &= 2\hat{\mathbf{r}} \partial_z u_r + 2\hat{\boldsymbol{\phi}} \partial_z u_\phi + 2\hat{\mathbf{z}} \partial_z u_z + \hat{\boldsymbol{\phi}} \left(\frac{1}{r} \partial_\phi u_z - \partial_z u_\phi \right) - \hat{\mathbf{r}} (\partial_z u_r - \partial_r u_z) \\ &= \hat{\mathbf{r}} (2\partial_z u_r - \partial_z u_r + \partial_r u_z) + \hat{\boldsymbol{\phi}} \left(2\partial_z u_\phi + \frac{1}{r} \partial_\phi u_z - \partial_z u_\phi \right) + \hat{\mathbf{z}} (2\partial_z u_z) \\ &= \hat{\mathbf{r}} (\partial_z u_r + \partial_r u_z) + \hat{\boldsymbol{\phi}} \left(\partial_z u_\phi + \frac{1}{r} \partial_\phi u_z \right) + \hat{\mathbf{z}} (2\partial_z u_z). \end{aligned} \quad (\text{B.25})$$

For our stress tensor

$$\boldsymbol{\sigma}_{\hat{\mathbf{z}}} = -p\hat{\mathbf{z}} + 2\mu\mathbf{e}_{\hat{\mathbf{z}}}, \quad (\text{B.26})$$

we can now read off our components by taking dot products to yield

$$\sigma_{zz} = -p + 2\mu \frac{\partial u_z}{\partial z}, \quad (\text{B.27a})$$

$$\sigma_{zr} = \mu \left(\frac{\partial u_r}{\partial z} + \frac{\partial u_z}{\partial r} \right), \quad (\text{B.27b})$$

$$\sigma_{z\phi} = \mu \left(\frac{\partial u_\phi}{\partial z} + \frac{1}{r} \frac{\partial u_z}{\partial \phi} \right). \quad (\text{B.27c})$$

B.3.4 *Summary.*

$$\sigma_{rr} = -p + 2\mu \frac{\partial u_r}{\partial r}, \quad (\text{B.28a})$$

$$\sigma_{\phi\phi} = -p + 2\mu \left(\frac{1}{r} \frac{\partial u_\phi}{\partial \phi} + \frac{u_r}{r} \right), \quad (\text{B.28b})$$

$$\sigma_{zz} = -p + 2\mu \frac{\partial u_z}{\partial z}, \quad (\text{B.28c})$$

$$\sigma_{r\phi} = \mu \left(\frac{\partial u_\phi}{\partial r} + \frac{1}{r} \frac{\partial u_r}{\partial \phi} - \frac{u_\phi}{r} \right), \quad (\text{B.28d})$$

$$\sigma_{\phi z} = \mu \left(\frac{1}{r} \frac{\partial u_z}{\partial \phi} + \frac{\partial u_\phi}{\partial z} \right), \quad (\text{B.28e})$$

$$\sigma_{zr} = \mu \left(\frac{\partial u_r}{\partial z} + \frac{\partial u_z}{\partial r} \right). \quad (\text{B.28f})$$

B.4 SPHERICAL STRAIN TENSOR.

Having done a first order cylindrical derivation of the strain tensor, let us also do the spherical case for completeness. Would this have much utility in fluids? Perhaps for flow over a spherical barrier? We need the gradient in spherical coordinates. Recall that our spherical coordinate velocity was

$$\frac{d\mathbf{r}}{dt} = \hat{\mathbf{r}}\dot{r} + \hat{\boldsymbol{\theta}}(r\dot{\theta}) + \hat{\boldsymbol{\phi}}(r \sin \theta \dot{\phi}), \quad (\text{B.29})$$

and our gradient mirrors this structure

$$\nabla = \hat{\mathbf{r}} \frac{\partial}{\partial r} + \hat{\boldsymbol{\theta}} \frac{1}{r} \frac{\partial}{\partial \theta} + \hat{\boldsymbol{\phi}} \frac{1}{r \sin \theta} \frac{\partial}{\partial \phi}. \quad (\text{B.30})$$

Referring back to eq. (A.51) where we noted that the unit vector differentials were

$$d\hat{\mathbf{r}} = \hat{\boldsymbol{\phi}} \sin \theta d\phi + \hat{\boldsymbol{\theta}} d\theta, \quad (\text{B.31a})$$

$$d\hat{\boldsymbol{\theta}} = \hat{\boldsymbol{\phi}} \cos \theta d\phi - \hat{\mathbf{r}} d\theta, \quad (\text{B.31b})$$

$$d\hat{\boldsymbol{\phi}} = -(\hat{\mathbf{r}} \sin \theta + \hat{\boldsymbol{\theta}} \cos \theta) d\phi, \quad (\text{B.31c})$$

and can use those to read off the partials of all the unit vectors

$$\begin{aligned} \frac{\partial \hat{\mathbf{r}}}{\partial \{r, \theta, \phi\}} &= \{0, \hat{\boldsymbol{\theta}}, \hat{\boldsymbol{\phi}} \sin \theta\} \\ \frac{\partial \hat{\boldsymbol{\theta}}}{\partial \{r, \theta, \phi\}} &= \{0, -\hat{\mathbf{r}}, \hat{\boldsymbol{\phi}} \cos \theta\} \\ \frac{\partial \hat{\boldsymbol{\phi}}}{\partial \{r, \theta, \phi\}} &= \{0, 0, -\hat{\mathbf{r}} \sin \theta - \hat{\boldsymbol{\theta}} \cos \theta\}. \end{aligned} \quad (\text{B.32})$$

Finally, our velocity in spherical coordinates is just

$$\mathbf{u} = \hat{\mathbf{r}}u_r + \hat{\boldsymbol{\theta}}u_\theta + \hat{\boldsymbol{\phi}}u_\phi, \quad (\text{B.33})$$

from which we can now compute the curl, and the directional derivative. Starting with the curl we have

$$\begin{aligned}
 \nabla \wedge \mathbf{u} &= \left(\hat{\mathbf{r}} \frac{\partial}{\partial r} + \hat{\boldsymbol{\theta}} \frac{1}{r} \frac{\partial}{\partial \theta} + \hat{\boldsymbol{\phi}} \frac{1}{r \sin \theta} \frac{\partial}{\partial \phi} \right) \wedge (\hat{\mathbf{r}} u_r + \hat{\boldsymbol{\theta}} u_\theta + \hat{\boldsymbol{\phi}} u_\phi) \\
 &= \hat{\mathbf{r}} \wedge \hat{\boldsymbol{\theta}} \left(\partial_r u_\theta - \frac{1}{r} \partial_\theta u_r \right) \\
 &\quad + \hat{\boldsymbol{\theta}} \wedge \hat{\boldsymbol{\phi}} \left(\frac{1}{r} \partial_\theta u_\phi - \frac{1}{r \sin \theta} \partial_\phi u_\theta \right) \\
 &\quad + \hat{\boldsymbol{\phi}} \wedge \hat{\mathbf{r}} \left(\frac{1}{r \sin \theta} \partial_\phi u_r - \partial_r u_\phi \right) \\
 &\quad + \frac{1}{r} \hat{\boldsymbol{\theta}} \wedge \left(\begin{array}{c} -\hat{\mathbf{r}} \quad \quad \quad \mathbf{o} \\ \boxed{u_\theta \partial_\theta \hat{\boldsymbol{\theta}}} + \boxed{u_\phi \partial_\theta \hat{\boldsymbol{\phi}}} \end{array} \right) \\
 &\quad + \frac{1}{r \sin \theta} \hat{\boldsymbol{\phi}} \wedge \left(\begin{array}{c} \hat{\boldsymbol{\phi}} \cos \theta \\ \boxed{u_\theta \partial_\phi \hat{\boldsymbol{\theta}}} + \boxed{u_\phi \partial_\phi \hat{\boldsymbol{\phi}}} \\ -\hat{\mathbf{r}} \sin \theta - \hat{\boldsymbol{\theta}} \cos \theta \end{array} \right), \tag{B.34}
 \end{aligned}$$

so we have

$$\begin{aligned}
 \nabla \wedge \mathbf{u} &= \hat{\mathbf{r}} \wedge \hat{\boldsymbol{\theta}} \left(\partial_r u_\theta - \frac{1}{r} \partial_\theta u_r + \frac{u_\theta}{r} \right) + \hat{\boldsymbol{\theta}} \\
 &\quad \wedge \hat{\boldsymbol{\phi}} \left(\frac{1}{r} \partial_\theta u_\phi - \frac{1}{r \sin \theta} \partial_\phi u_\theta + \frac{u_\phi \cot \theta}{r} \right) \\
 &\quad + \hat{\boldsymbol{\phi}} \wedge \hat{\mathbf{r}} \left(\frac{1}{r \sin \theta} \partial_\phi u_r - \partial_r u_\phi - \frac{u_\phi}{r} \right). \tag{B.35}
 \end{aligned}$$

B.4.1 *Outwards radial normal* $\hat{\mathbf{n}} = \hat{\mathbf{r}}$.

The directional derivative portion of our strain is

$$\begin{aligned}
 2(\hat{\mathbf{r}} \cdot \nabla) \mathbf{u} &= 2\partial_r(\hat{\mathbf{r}} u_r + \hat{\boldsymbol{\theta}} u_\theta + \hat{\boldsymbol{\phi}} u_\phi) \\
 &= 2(\hat{\mathbf{r}} \partial_r u_r + \hat{\boldsymbol{\theta}} \partial_r u_\theta + \hat{\boldsymbol{\phi}} \partial_r u_\phi). \tag{B.36}
 \end{aligned}$$

The other portion of our strain tensor is

$$\begin{aligned}
 (\nabla \wedge \mathbf{u}) \cdot \hat{\mathbf{r}} &= (\hat{\mathbf{r}} \wedge \hat{\boldsymbol{\theta}}) \cdot \hat{\mathbf{r}} \left(\partial_r u_\theta - \frac{1}{r} \partial_\theta u_r + \frac{u_\theta}{r} \right) \\
 &\quad + (\hat{\boldsymbol{\theta}} \wedge \hat{\boldsymbol{\phi}}) \cdot \hat{\mathbf{r}} \left(\frac{1}{r} \partial_\theta u_\phi - \frac{1}{r \sin \theta} \partial_\phi u_\theta + \frac{u_\phi \cot \theta}{r} \right) \\
 &\quad + (\hat{\boldsymbol{\phi}} \wedge \hat{\mathbf{r}}) \cdot \hat{\mathbf{r}} \left(\frac{1}{r \sin \theta} \partial_\phi u_r - \partial_r u_\phi - \frac{u_\phi}{r} \right) \quad (\text{B.37}) \\
 &= -\hat{\boldsymbol{\theta}} \left(\partial_r u_\theta - \frac{1}{r} \partial_\theta u_r + \frac{u_\theta}{r} \right) \\
 &\quad + \hat{\boldsymbol{\phi}} \left(\frac{1}{r \sin \theta} \partial_\phi u_r - \partial_r u_\phi - \frac{u_\phi}{r} \right).
 \end{aligned}$$

Putting these together we find

$$\begin{aligned}
 2\mathbf{e}_{\hat{\mathbf{r}}} &= 2(\hat{\mathbf{r}} \cdot \nabla) \mathbf{u} + (\nabla \wedge \mathbf{u}) \cdot \hat{\mathbf{r}} \\
 &= 2(\hat{\mathbf{r}} \partial_r u_r + \hat{\boldsymbol{\theta}} \partial_r u_\theta + \hat{\boldsymbol{\phi}} \partial_r u_\phi) - \hat{\boldsymbol{\theta}} \left(\partial_r u_\theta - \frac{1}{r} \partial_\theta u_r + \frac{u_\theta}{r} \right) \\
 &\quad + \hat{\boldsymbol{\phi}} \left(\frac{1}{r \sin \theta} \partial_\phi u_r - \partial_r u_\phi - \frac{u_\phi}{r} \right) \quad (\text{B.38}) \\
 &= \hat{\mathbf{r}} (2\partial_r u_r) + \hat{\boldsymbol{\theta}} \left(2\partial_r u_\theta - \partial_r u_\theta + \frac{1}{r} \partial_\theta u_r - \frac{u_\theta}{r} \right) \\
 &\quad + \hat{\boldsymbol{\phi}} \left(2\partial_r u_\phi + \frac{1}{r \sin \theta} \partial_\phi u_r - \partial_r u_\phi - \frac{u_\phi}{r} \right),
 \end{aligned}$$

which gives

$$\begin{aligned}
 2\mathbf{e}_{\hat{\mathbf{r}}} &= \hat{\mathbf{r}} (2\partial_r u_r) + \hat{\boldsymbol{\theta}} \left(\partial_r u_\theta + \frac{1}{r} \partial_\theta u_r - \frac{u_\theta}{r} \right) \\
 &\quad + \hat{\boldsymbol{\phi}} \left(\partial_r u_\phi + \frac{1}{r \sin \theta} \partial_\phi u_r - \frac{u_\phi}{r} \right). \quad (\text{B.39})
 \end{aligned}$$

For our stress tensor

$$\boldsymbol{\sigma}_{\hat{\mathbf{r}}} = -p\hat{\mathbf{r}} + 2\mu\mathbf{e}_{\hat{\mathbf{r}}}. \quad (\text{B.40})$$

We can now read off our components by taking dot products

$$\sigma_{rr} = -p + 2\mu \frac{\partial u_r}{\partial r}, \quad (\text{B.41a})$$

$$\sigma_{r\theta} = \mu \left(\frac{\partial u_\theta}{\partial r} + \frac{1}{r} \frac{\partial u_r}{\partial \theta} - \frac{u_\theta}{r} \right), \quad (\text{B.41b})$$

$$\sigma_{r\phi} = \mu \left(\frac{\partial u_\phi}{\partial r} + \frac{1}{r \sin \theta} \frac{\partial u_r}{\partial \phi} - \frac{u_\phi}{r} \right). \quad (\text{B.41c})$$

This is consistent with (15.20) from [12] (after adjusting for minor notational differences).

B.4.2 Polar normal $\hat{\mathbf{n}} = \hat{\boldsymbol{\theta}}$.

Now let us do the $\hat{\boldsymbol{\theta}}$ direction. The directional derivative portion of our strain will be a bit more work to compute because we have θ variation of the unit vectors

$$\begin{aligned} & (\hat{\boldsymbol{\theta}} \cdot \nabla) \mathbf{u} \\ &= \frac{1}{r} \partial_\theta (\hat{\mathbf{r}} u_r + \hat{\boldsymbol{\theta}} u_\theta + \hat{\boldsymbol{\phi}} u_\phi) \\ &= \frac{1}{r} (\hat{\mathbf{r}} \partial_\theta u_r + \hat{\boldsymbol{\theta}} \partial_\theta u_\theta + \hat{\boldsymbol{\phi}} \partial_\theta u_\phi) + \frac{1}{r} ((\partial_\theta \hat{\mathbf{r}}) u_r + (\partial_\theta \hat{\boldsymbol{\theta}}) u_\theta + (\partial_\theta \hat{\boldsymbol{\phi}}) u_\phi) \\ &= \frac{1}{r} (\hat{\mathbf{r}} \partial_\theta u_r + \hat{\boldsymbol{\theta}} \partial_\theta u_\theta + \hat{\boldsymbol{\phi}} \partial_\theta u_\phi) + \frac{1}{r} (\hat{\boldsymbol{\theta}} u_r - \hat{\mathbf{r}} u_\theta), \end{aligned} \quad (\text{B.42})$$

so we have

$$2(\hat{\boldsymbol{\theta}} \cdot \nabla) \mathbf{u} = \frac{2}{r} \hat{\mathbf{r}} (\partial_\theta u_r - u_\theta) + \frac{2}{r} \hat{\boldsymbol{\theta}} (\partial_\theta u_\theta + u_r) + \frac{2}{r} \hat{\boldsymbol{\phi}} \partial_\theta u_\phi, \quad (\text{B.43})$$

and can move on to projecting our curl bivector onto the $\hat{\boldsymbol{\theta}}$ direction. That portion of our strain tensor is

$$\begin{aligned} & (\nabla \wedge \mathbf{u}) \cdot \hat{\boldsymbol{\theta}} \\ &= (\hat{\mathbf{r}} \wedge \hat{\boldsymbol{\theta}}) \cdot \hat{\boldsymbol{\theta}} \left(\partial_r u_\theta - \frac{1}{r} \partial_\theta u_r + \frac{u_\theta}{r} \right) \\ &\quad + (\hat{\boldsymbol{\theta}} \wedge \hat{\boldsymbol{\phi}}) \cdot \hat{\boldsymbol{\theta}} \left(\frac{1}{r} \partial_\theta u_\phi - \frac{1}{r \sin \theta} \partial_\phi u_\theta + \frac{u_\phi \cot \theta}{r} \right) \\ &\quad + (\hat{\boldsymbol{\phi}} \wedge \hat{\mathbf{r}}) \cdot \hat{\boldsymbol{\theta}} \left(\frac{1}{r \sin \theta} \partial_\phi u_r - \partial_r u_\phi - \frac{u_\phi}{r} \right) \\ &= \hat{\mathbf{r}} \left(\partial_r u_\theta - \frac{1}{r} \partial_\theta u_r + \frac{u_\theta}{r} \right) - \hat{\boldsymbol{\phi}} \left(\frac{1}{r} \partial_\theta u_\phi - \frac{1}{r \sin \theta} \partial_\phi u_\theta + \frac{u_\phi \cot \theta}{r} \right). \end{aligned}$$

(B.44)

Putting these together we find

$$\begin{aligned}
 2\mathbf{e}_{\hat{\theta}} &= 2(\hat{\theta} \cdot \nabla)\mathbf{u} + (\nabla \wedge \mathbf{u}) \cdot \hat{\theta} \\
 &= \frac{2}{r}\hat{\mathbf{r}}(\partial_{\theta}u_r - u_{\theta}) + \frac{2}{r}\hat{\theta}(\partial_{\theta}u_{\theta} + u_r) + \frac{2}{r}\hat{\phi}\partial_{\theta}u_{\phi} \\
 &\quad + \hat{\mathbf{r}}\left(\partial_r u_{\theta} - \frac{1}{r}\partial_{\theta}u_r + \frac{u_{\theta}}{r}\right) \\
 &\quad - \hat{\phi}\left(\frac{1}{r}\partial_{\theta}u_{\phi} - \frac{1}{r\sin\theta}\partial_{\phi}u_{\theta} + \frac{u_{\phi}\cot\theta}{r}\right).
 \end{aligned}
 \tag{B.45}$$

Which gives

$$\begin{aligned}
 2\mathbf{e}_{\hat{\theta}} &= \hat{\mathbf{r}}\left(\frac{1}{r}\partial_{\theta}u_r + \partial_r u_{\theta} - \frac{u_{\theta}}{r}\right) + \hat{\theta}\left(\frac{2}{r}\partial_{\theta}u_{\theta} + \frac{2}{r}u_r\right) \\
 &\quad + \hat{\phi}\left(\frac{1}{r}\partial_{\theta}u_{\phi} + \frac{1}{r\sin\theta}\partial_{\phi}u_{\theta} - \frac{u_{\phi}\cot\theta}{r}\right).
 \end{aligned}
 \tag{B.46}$$

For our stress tensor

$$\sigma_{\hat{\theta}} = -p\hat{\theta} + 2\mu e_{\hat{\theta}},
 \tag{B.47}$$

so we can now read off our components by taking dot products

$$\sigma_{\theta\theta} = -p + \mu\left(\frac{2}{r}\frac{\partial u_{\theta}}{\partial\theta} + \frac{2}{r}u_r\right),
 \tag{B.48a}$$

$$\sigma_{\theta\phi} = \mu\left(\frac{1}{r}\frac{\partial u_{\phi}}{\partial\theta} + \frac{1}{r\sin\theta}\frac{\partial u_{\theta}}{\partial\phi} - \frac{u_{\phi}\cot\theta}{r}\right),
 \tag{B.48b}$$

$$\sigma_{\theta r} = \mu\left(\frac{1}{r}\frac{\partial u_r}{\partial\theta} + \frac{\partial u_{\theta}}{\partial r} - \frac{u_{\theta}}{r}\right).
 \tag{B.48c}$$

This again is consistent with (15.20) from [12].

B.4.3 *Azimuthal normal* $\hat{\mathbf{n}} = \hat{\boldsymbol{\phi}}$.

Finally, let us do the $\hat{\boldsymbol{\phi}}$ direction. This directional derivative portion of our strain will also be a bit more work to compute because we have $\hat{\boldsymbol{\phi}}$ variation of the unit vectors

$$\begin{aligned}
 (\hat{\boldsymbol{\phi}} \cdot \nabla) \mathbf{u} &= \frac{1}{r \sin \theta} \partial_{\phi} (\hat{\mathbf{r}} u_r + \hat{\boldsymbol{\theta}} u_{\theta} + \hat{\boldsymbol{\phi}} u_{\phi}) \\
 &= \frac{1}{r \sin \theta} (\hat{\mathbf{r}} \partial_{\phi} u_r + \hat{\boldsymbol{\theta}} \partial_{\phi} u_{\theta} + \hat{\boldsymbol{\phi}} \partial_{\phi} u_{\phi} + (\partial_{\phi} \hat{\mathbf{r}}) u_r + (\partial_{\phi} \hat{\boldsymbol{\theta}}) u_{\theta} + (\partial_{\phi} \hat{\boldsymbol{\phi}}) u_{\phi}) \\
 &= \frac{1}{r \sin \theta} \left(\hat{\mathbf{r}} \partial_{\phi} u_r + \hat{\boldsymbol{\theta}} \partial_{\phi} u_{\theta} \right. \\
 &\quad \left. + \hat{\boldsymbol{\phi}} \partial_{\phi} u_{\phi} + \hat{\boldsymbol{\phi}} \sin \theta u_r + \hat{\boldsymbol{\phi}} \cos \theta u_{\theta} \right. \\
 &\quad \left. - (\hat{\mathbf{r}} \sin \theta + \hat{\boldsymbol{\theta}} \cos \theta) u_{\phi} \right),
 \end{aligned} \tag{B.49}$$

so we have

$$\begin{aligned}
 2(\hat{\boldsymbol{\phi}} \cdot \nabla) \mathbf{u} &= 2\hat{\mathbf{r}} \left(\frac{1}{r \sin \theta} \partial_{\phi} u_r - \frac{u_{\phi}}{r} \right) + 2\hat{\boldsymbol{\theta}} \left(\frac{1}{r \sin \theta} \partial_{\phi} u_{\theta} - \frac{1}{r} \cot \theta u_{\phi} \right) \\
 &\quad + 2\hat{\boldsymbol{\phi}} \left(\frac{1}{r \sin \theta} \partial_{\phi} u_{\phi} + \frac{1}{r} u_r + \frac{1}{r} \cot \theta u_{\theta} \right),
 \end{aligned} \tag{B.50}$$

and can move on to projecting our curl bivector onto the $\hat{\boldsymbol{\phi}}$ direction. That portion of our strain tensor is

$$\begin{aligned}
 (\nabla \wedge \mathbf{u}) \cdot \hat{\boldsymbol{\phi}} &= (\hat{\mathbf{r}} \wedge \hat{\boldsymbol{\theta}}) \cdot \hat{\boldsymbol{\phi}} \left(\partial_r u_{\theta} - \frac{1}{r} \partial_{\theta} u_r + \frac{u_{\theta}}{r} \right) \\
 &\quad + (\hat{\boldsymbol{\theta}} \wedge \hat{\boldsymbol{\phi}}) \cdot \hat{\boldsymbol{\phi}} \left(\frac{1}{r} \partial_{\theta} u_{\phi} - \frac{1}{r \sin \theta} \partial_{\phi} u_{\theta} + \frac{u_{\phi} \cot \theta}{r} \right) \\
 &\quad + (\hat{\boldsymbol{\phi}} \wedge \hat{\mathbf{r}}) \cdot \hat{\boldsymbol{\phi}} \left(\frac{1}{r \sin \theta} \partial_{\phi} u_r - \partial_r u_{\phi} - \frac{u_{\phi}}{r} \right) \\
 &= \hat{\boldsymbol{\theta}} \left(\frac{1}{r} \partial_{\theta} u_{\phi} - \frac{1}{r \sin \theta} \partial_{\phi} u_{\theta} + \frac{u_{\phi} \cot \theta}{r} \right) \\
 &\quad - \hat{\mathbf{r}} \left(\frac{1}{r \sin \theta} \partial_{\phi} u_r - \partial_r u_{\phi} - \frac{u_{\phi}}{r} \right).
 \end{aligned} \tag{B.51}$$

Putting these together we find

$$\begin{aligned}
 2\mathbf{e}_{\hat{\theta}} &= 2(\hat{\phi} \cdot \nabla)\mathbf{u} + (\nabla \wedge \mathbf{u}) \cdot \hat{\phi} \\
 &= 2\hat{\mathbf{r}} \left(\frac{1}{r \sin \theta} \partial_{\phi} u_r - \frac{u_{\phi}}{r} \right) + 2\hat{\boldsymbol{\theta}} \left(\frac{1}{r \sin \theta} \partial_{\phi} u_{\theta} - \frac{1}{r} \cot \theta u_{\phi} \right) \\
 &\quad + 2\hat{\phi} \left(\frac{1}{r \sin \theta} \partial_{\phi} u_{\phi} + \frac{1}{r} u_r + \frac{1}{r} \cot \theta u_{\theta} \right) \\
 &\quad + \hat{\boldsymbol{\theta}} \left(\frac{1}{r} \partial_{\theta} u_{\phi} - \frac{1}{r \sin \theta} \partial_{\phi} u_{\theta} + \frac{u_{\phi} \cot \theta}{r} \right) \\
 &\quad - \hat{\mathbf{r}} \left(\frac{1}{r \sin \theta} \partial_{\phi} u_r - \partial_r u_{\phi} - \frac{u_{\phi}}{r} \right),
 \end{aligned} \tag{B.52}$$

which gives

$$\begin{aligned}
 2\mathbf{e}_{\hat{\phi}} &= \hat{\mathbf{r}} \left(\frac{\partial_{\phi} u_r}{r \sin \theta} - \frac{u_{\phi}}{r} + \partial_r u_{\phi} \right) + \hat{\boldsymbol{\theta}} \left(\frac{\partial_{\phi} u_{\theta}}{r \sin \theta} - \frac{u_{\phi} \cot \theta}{r} + \frac{\partial_{\theta} u_{\phi}}{r} \right) \\
 &\quad + 2\hat{\phi} \left(\frac{\partial_{\phi} u_{\phi}}{r \sin \theta} + \frac{u_r}{r} + \frac{\cot \theta u_{\theta}}{r} \right).
 \end{aligned} \tag{B.53}$$

For our stress tensor

$$\boldsymbol{\sigma}_{\hat{\phi}} = -p\hat{\phi} + 2\mu\mathbf{e}_{\hat{\phi}}, \tag{B.54}$$

so we can now read off our components by taking dot products

$$\sigma_{\phi\phi} = -p + 2\mu \left(\frac{1}{r \sin \theta} \frac{\partial u_{\phi}}{\partial \phi} + \frac{u_r}{r} + \frac{\cot \theta u_{\theta}}{r} \right), \tag{B.55a}$$

$$\sigma_{\phi r} = \mu \left(\frac{1}{r \sin \theta} \frac{\partial u_r}{\partial \phi} - \frac{u_{\phi}}{r} + \frac{\partial u_{\phi}}{\partial r} \right), \tag{B.55b}$$

$$\sigma_{\phi\theta} = \mu \left(\frac{1}{r \sin \theta} \frac{\partial u_{\theta}}{\partial \phi} - \frac{u_{\phi} \cot \theta}{r} + \frac{1}{r} \frac{\partial u_{\phi}}{\partial \theta} \right). \tag{B.55c}$$

This again is consistent with (15.20) from [12].

B.4.4 *Summary.*

$$\sigma_{rr} = -p + 2\mu \frac{\partial u_r}{\partial r}, \quad (\text{B.56a})$$

$$\sigma_{\theta\theta} = -p + 2\mu \left(\frac{1}{r} \frac{\partial u_\theta}{\partial \theta} + \frac{u_r}{r} \right), \quad (\text{B.56b})$$

$$\sigma_{\phi\phi} = -p + 2\mu \left(\frac{1}{r \sin \theta} \frac{\partial u_\phi}{\partial \phi} + \frac{u_r}{r} + \frac{\cot \theta u_\theta}{r} \right), \quad (\text{B.56c})$$

$$\sigma_{r\theta} = \mu \left(\frac{\partial u_\theta}{\partial r} + \frac{1}{r} \frac{\partial u_r}{\partial \theta} - \frac{u_\theta}{r} \right) \quad (\text{B.56d})$$

$$\sigma_{\theta\phi} = \mu \left(\frac{1}{r \sin \theta} \frac{\partial u_\theta}{\partial \phi} - \frac{u_\phi \cot \theta}{r} + \frac{1}{r} \frac{\partial u_\phi}{\partial \theta} \right), \quad (\text{B.56e})$$

$$\sigma_{\phi r} = \mu \left(\frac{1}{r \sin \theta} \frac{\partial u_r}{\partial \phi} - \frac{u_\phi}{r} + \frac{\partial u_\phi}{\partial r} \right). \quad (\text{B.56f})$$



POISSON'S RATIO, SHEAR MODULUS.

Young's modulus is given in eq. (3.55) (equation (43) in the Professor's notes) as

$$E = \frac{\mu(3\lambda + 2\mu)}{\lambda + \mu}, \quad (\text{C.1})$$

and for Poisson's ratio eq. (3.60) (equation (46) in the Professor's notes) we have

$$\nu = -\frac{e_{22}}{e_{11}} = \frac{\lambda}{2(\lambda + \mu)}. \quad (\text{C.2})$$

Let us derive the other stated relationships (equation (47) in the Professor's notes). I get

$$\begin{aligned} 2(\lambda + \mu)\nu &= \lambda \\ &\implies \\ \lambda(2\nu - 1) &= -2\mu\nu, \end{aligned} \quad (\text{C.3})$$

or

$$\lambda = \frac{2\mu\nu}{1 - 2\nu}. \quad (\text{C.4})$$

For substitution into the Young's modulus equation calculate

$$\begin{aligned} \lambda + \mu &= \frac{2\mu\nu}{1 - 2\nu} + \mu \\ &= \mu \left(\frac{2\nu}{1 - 2\nu} + 1 \right) \\ &= \mu \frac{2\nu + 1 - 2\nu}{1 - 2\nu} \\ &= \frac{\mu}{1 - 2\nu} \end{aligned} \quad (\text{C.5})$$

and

$$\begin{aligned}
 3\lambda + 2\mu &= 3\frac{\mu}{1-2\nu} - \mu \\
 &= \mu\frac{3-(1-2\nu)}{1-2\nu} \\
 &= \mu\frac{2+2\nu}{1-2\nu} \\
 &= 2\mu\frac{1+\nu}{1-2\nu}.
 \end{aligned}
 \tag{C.6}$$

Putting these together we find

$$\begin{aligned}
 E &= \frac{\mu(3\lambda + 2\mu)}{\lambda + \mu} \\
 &= \mu 2\mu\frac{1+\nu}{1-2\nu}\frac{1-2\nu}{\mu} \\
 &= 2\mu(1+\nu).
 \end{aligned}
 \tag{C.7}$$

Rearranging we have

$$\mu = \frac{E}{2(1+\nu)}.
 \tag{C.8}$$

This matches (5.9) in the text (where σ is used instead of ν). We also find

$$\begin{aligned}
 \lambda &= \frac{2\mu\nu}{1-2\nu} \\
 &= \frac{\nu}{1-2\nu}\frac{E}{1+\nu}.
 \end{aligned}
 \tag{C.9}$$

D

SURFACES.

D.1 NORMALS AND TANGENTS.

Consider a surface with some variation as in fig. D.1 We can

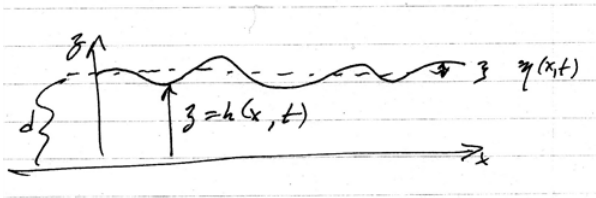

Figure D.1: Variable surface geometries.

construct an equation for the surface

$$z = h(x, t), \quad (\text{D.1})$$

or equivalently

$$\phi = z - h(x, t) = 0. \quad (\text{D.2})$$

If d is the average height, with the $\eta(x, t)$ the variation of the height from this average, we can also write

$$h = d + \eta(x, t), \quad (\text{D.3})$$

and for the surface

$$\phi = d - \eta(x, t) = 0. \quad (\text{D.4})$$

We can generalize this and define a surface function as one that satisfies

$$\phi = d - \eta(x, t) = \text{constant}. \quad (\text{D.5})$$

Consider a small section of a 2D surface as in fig. D.2 With $\phi =$

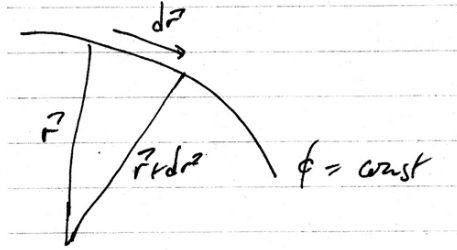

Figure D.2: A vector differential element.

constant on the surface, we have for $\phi = \phi(x, y, z)$

$$d\phi = 0, \quad (\text{D.6})$$

or, in coordinates

$$\begin{aligned} d\phi &= \frac{\partial\phi}{\partial x}dx + \frac{\partial\phi}{\partial y}dy + \frac{\partial\phi}{\partial z}dz \\ &= \nabla\phi \cdot d\mathbf{r}. \end{aligned} \quad (\text{D.7})$$

Pictorially we see that $d\mathbf{r}$ is tangential to the surface, but since we also have

$$\nabla\phi \cdot d\mathbf{r} = 0, \quad (\text{D.8})$$

the implication is that the gradient is normal to the surface

$$d\mathbf{r} \perp \nabla\phi. \quad (\text{D.9})$$

We can therefore construct the unit normal by scaling the gradient

$$\hat{\mathbf{n}} = \frac{\nabla\phi}{|\nabla\phi|}, \quad (\text{D.10})$$

since the direction of $\hat{\mathbf{n}}$ is $\nabla\phi$. For example, in our case where $\phi = y - h(x, t)$, we have

$$\nabla\phi = \hat{\mathbf{x}} \left(-\frac{\partial h}{\partial x} \right) + \hat{\mathbf{y}}. \quad (\text{D.11})$$

This has norm

$$|\nabla\phi| = \sqrt{1 + \left(\frac{\partial h}{\partial x} \right)^2}, \quad (\text{D.12})$$

and our unit normal is

$$\hat{\mathbf{n}} = \frac{\hat{\mathbf{x}} \left(-\frac{\partial h}{\partial x} \right) + \hat{\mathbf{y}}}{\sqrt{1 + \left(\frac{\partial h}{\partial x} \right)^2}}. \quad (\text{D.13})$$

By inspection we can also express the unit tangent, and we have for both

$$\begin{aligned} \hat{\mathbf{n}} &= \frac{1}{\sqrt{1 + \left(\frac{\partial h}{\partial x} \right)^2}} \left(-\frac{\partial h}{\partial x}, 1 \right) \\ \hat{\boldsymbol{\tau}} &= \frac{1}{\sqrt{1 + \left(\frac{\partial h}{\partial x} \right)^2}} \left(1, \frac{\partial h}{\partial x} \right). \end{aligned} \quad (\text{D.14})$$

D.2 REVIEW. SURFACES.

We are considering a surface as depicted in fig. D.3 With the surface

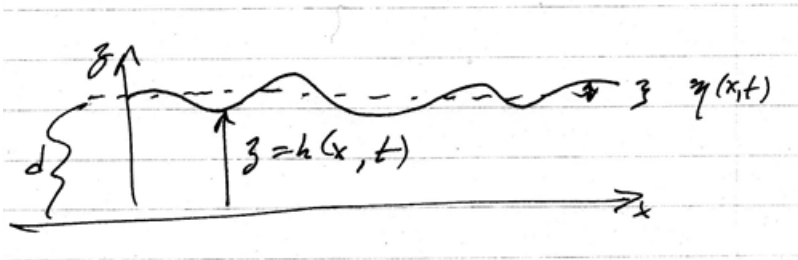

Figure D.3: Variable surface geometries.

height given by

$$z = h(x, t), \quad (\text{D.15})$$

where this describes the interface. Taking the difference

$$\phi = z - h(x, t) = 0, \quad (\text{D.16})$$

we define a surface. We considered a small displacement as in fig. D.4. Recall that if ϕ is a constant, then $\nabla\phi$ is a normal to the

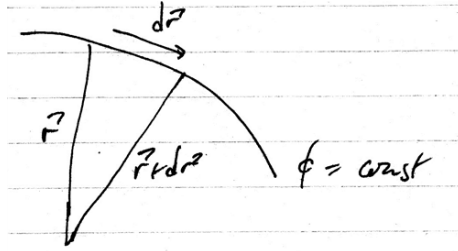

Figure D.4: A vector differential element.

surface. We showed this by considering the differential

$$\begin{aligned}
 0 &= d\phi \\
 &= \frac{\partial\phi}{\partial x}dx + \frac{\partial\phi}{\partial y}dy + \frac{\partial\phi}{\partial z}dz \\
 &= (\nabla\phi) \cdot d\mathbf{r}.
 \end{aligned}
 \tag{D.17}$$

We can construct the unit normal by scaling. For our 1D example we have

$$\begin{aligned}
 \hat{\mathbf{n}} &= \frac{\nabla\phi}{|\nabla\phi|} \\
 &= \frac{1}{|\nabla\phi|} \left(\frac{\partial\phi}{\partial x}, \frac{\partial\phi}{\partial y} \right)
 \end{aligned}
 \tag{D.18}$$

so that our unit normal is

$$\hat{\mathbf{n}} = \frac{1}{\sqrt{1+(h')^2}} \left(-\frac{\partial h}{\partial x}, 1 \right)
 \tag{D.19}$$

A unit tangent can also be constructed by inspection

$$\hat{\mathbf{t}} = \frac{1}{\sqrt{1+(h')^2}} \left(1, \frac{\partial h}{\partial x} \right).
 \tag{D.20}$$

E

IDENTITIES AND PROOFS.

E.1 ERROR FUNCTION PROPERTIES.

Let us verify the value of $\text{erf}(\infty)$. In the square that is

$$\begin{aligned}(\text{erf}(\infty))^2 &= \frac{4}{\pi} \int_0^\infty e^{-s^2} ds \int_0^\infty e^{-t^2} dt \\ &= \frac{1}{\pi} \int_{-\infty}^\infty e^{-s^2} ds \int_{-\infty}^\infty e^{-t^2} dt \\ &= \frac{1}{\pi} 2\pi \int_0^\infty e^{-r^2} r dr \\ &= \int_\infty^0 d(e^{-r^2}) \\ &= 1.\end{aligned}\tag{E.1}$$

E.2 A FOURIER SERIES REFRESHER.

Here is a quick re-derivation of how to obtain the Fourier coefficients for a trigonometric Fourier series in exponential form. This is performed over an arbitrary interval to make it easy to apply to more specific problems.

Suppose we have a function that is defined in terms of a trigonometric Fourier sum

$$\phi(x) = \sum c_k e^{i\omega_k x},\tag{E.2}$$

where the domain of interest is $x \in [a, b]$. Stating the problem this way avoids any issue of existence. We know c_k exists, but just want to find what they are given some other representation of the function.

Multiplying and integrating over our domain we have

$$\begin{aligned} \int_a^b \phi(x)e^{-i\omega mx} dx &= \sum c_k \int_a^b e^{i\omega(k-m)x} dx \\ &= c_m(b-a) + \sum_{k \neq m} \frac{e^{i\omega(k-m)b} - e^{i\omega(k-m)a}}{i\omega(k-m)}. \end{aligned} \tag{E.3}$$

We want all the terms in the sum to be zero, requiring equality of the exponentials, or

$$e^{i\omega(k-m)(b-a)} = 1, \tag{E.4}$$

or

$$\omega = \frac{2\pi}{b-a}. \tag{E.5}$$

This fixes our Fourier coefficients

$$c_m = \frac{1}{b-a} \int_a^b \phi(x)e^{-2\pi imx/(b-a)} dx. \tag{E.6}$$

So, for example, if we wished for the correct (but unnormalized) Fourier basis for a $[0, 1]$ interval, we see that we use the functions $e^{2\pi ix}$, or the sine and cosine equivalents, as our basis elements.

E.3 VECTOR IDENTITIES.

$$\begin{aligned} \left(\nabla \frac{1}{2} \mathbf{u}^2 + (\nabla \times \mathbf{u}) \times \mathbf{u} \right)_i &= \partial_i \frac{1}{2} u_j u_j + \partial_a u_b \epsilon_{abr} u_s \epsilon_{rsi} \\ &= u_j \partial_i u_j + \partial_a u_b u_s \delta_{si}^{[ab]} \\ &= u_j \partial_i u_j + u_s \partial_s u_i - u_s \partial_i u_s \\ &= (\mathbf{u} \cdot \nabla) \mathbf{u}_i. \end{aligned} \tag{E.7}$$

Also observe that our claim that $\mathbf{u} \cdot (\mathbf{u} \times (\nabla \mathbf{u})) = 0$ follows easily after expansion in coordinates

$$\mathbf{u} \cdot (\mathbf{u} \times (\nabla \times \mathbf{u})) = u_i u_s (\partial_s u_i - \partial_i u_s). \tag{E.8}$$

We have got a symmetric and antisymmetric factor in the summation, so the end result is zero.

F

GENERAL INCLINED FLOW PROBLEM.

F.1 MOTIVATION.

In an informal discussion after class, it was claimed that the steady state flow down a plane would have constant height, unless you bring surface tension effects into the mix. Part of that statement just does not make sense to me. Consider the forces acting on the fluid in the fig. F.1 In the inclined reference frame we have a component

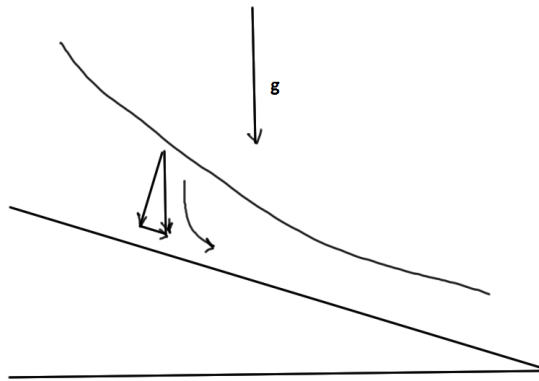

Figure F.1: Gravitational force components acting on fluid flowing down a plane.

of the force acting downwards (in the negative y -axis direction), and have a component directed down the x -axis. Would not this act to both push the fluid down the plane and push part of the fluid downwards? I had expect this to introduce some vorticity as depicted.

While we are just about to start covered surface tension, perhaps this is just allowing the surface to vary, and then solving the Navier-Stokes equations that result. Let us try setting up the Navier-Stokes equation for steady state viscous flow down a plane without any assumption that the height is constant and see how far we can get.

F.2 EQUATIONS OF MOTION.

We will use the same coordinates as before, with the directions given as in fig. F.2. However, this time, we let the height $h(x)$ of the fluid at any distance x down the plane from the initial point vary. For viscous incompressible flow down the plane our equations of

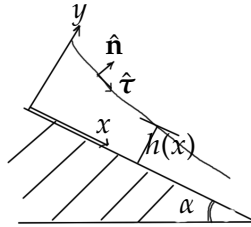

Figure F.2: Diagram of coordinates for inclined flow problem.

motion are

$$\rho \frac{\partial u}{\partial t} + \rho(u\partial_x + v\partial_y)u = -\partial_x p + \mu (\partial_{xx} + \partial_{yy}) u + \rho g \sin \alpha, \quad (\text{F.1a})$$

$$\rho \frac{\partial v}{\partial t} + \rho(u\partial_x + v\partial_y)v = -\partial_y p + \mu (\partial_{xx} + \partial_{yy}) v - \rho g \cos \alpha, \quad (\text{F.1b})$$

$$0 = -\partial_z p, \quad (\text{F.1c})$$

$$0 = \partial_x u + \partial_y v. \quad (\text{F.1d})$$

Now, can we kill the time dependent term? Even allowing for u to vary with x and introducing a non-horizontal flow component, I think that we can. If the flow at $x = 0$ is constant, not varying at all with time, I think it makes sense that we will have no time dependence in the flow for $x \neq 0$. So, I believe that our starting point is as above, but with the time derivatives killed off. That is

$$\rho(u\partial_x + v\partial_y)u = -\partial_x p + \mu (\partial_{xx} + \partial_{yy}) u + \rho g \sin \alpha, \quad (\text{F.2a})$$

$$\rho(u\partial_x + v\partial_y)v = -\partial_y p + \mu(\partial_{xx} + \partial_{yy})v - \rho g \cos \alpha, \quad (\text{F.2b})$$

$$0 = -\partial_z p, \quad (\text{F.2c})$$

$$0 = \partial_x u + \partial_y v. \quad (\text{F.2d})$$

These do not look particularly easy to solve, and we have not even set up the boundary value constraints yet. Let us do that next.

F.3 BOUNDARY VALUE CONSTRAINTS.

One of our constraints is the no-slip condition for the velocity components at the base of the slope

$$u(x, 0) = v(x, 0) = 0. \quad (\text{F.3})$$

We should also have a zero tangential component to the traction vector at the interface. We need to consider some geometry, and refer to fig. F.3 A position vector on the surface has the value

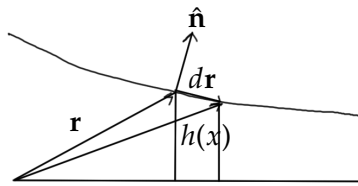

Figure F.3: Differential vector element.

$$\mathbf{r} = x\hat{\mathbf{x}} + h\hat{\mathbf{y}} \quad (\text{F.4})$$

so that a differential element on the surface, tangential to the surface is proportional to

$$d\mathbf{r} = \left(\hat{\mathbf{x}} + \frac{dh}{dx}\hat{\mathbf{y}} \right) dx, \quad (\text{F.5})$$

so our unit tangent vector in the direction depicted in the figure is

$$\hat{\boldsymbol{\tau}} = \frac{1}{\sqrt{1+(h')^2}} (1, h'). \tag{F.6}$$

The outwards facing normal has a value, up to a factor of plus or minus one, of

$$\hat{\boldsymbol{n}} = \frac{1}{\sqrt{1+(h')^2}} (h', -1). \tag{F.7}$$

We can fix the orientation by considering the unit bivector

$$\begin{aligned} \hat{\boldsymbol{\tau}} \wedge \hat{\boldsymbol{n}} &= \frac{1}{1+(h')^2} (1, h') \wedge (h', -1) \\ &= \begin{vmatrix} 1 & h' \\ h' & -1 \end{vmatrix} \mathbf{e}_1 \mathbf{e}_2 \\ &= (-1 - (h')^2) \mathbf{e}_1 \mathbf{e}_2. \end{aligned} \tag{F.8}$$

So we really want the other orientation

$$\hat{\boldsymbol{n}} = \frac{1}{\sqrt{1+(h')^2}} (-h', 1). \tag{F.9}$$

Our traction vector relative to the normal $\hat{\boldsymbol{n}}$ is

$$\begin{aligned} \mathbf{t} &= \mathbf{e}_i T_{ij} n_j \\ &= \mathbf{e}_i (-p\delta_{ij} + \mu e_{ij}) n_j \\ &= -p\hat{\boldsymbol{n}} + \mu \mathbf{e}_i e_{ij} n_j. \end{aligned} \tag{F.10}$$

So the component in the tangential direction is

$$\begin{aligned} \mathbf{t} \cdot \hat{\boldsymbol{\tau}} &= -p\hat{\boldsymbol{n}} \cdot \hat{\boldsymbol{\tau}} + \mu \mathbf{e}_i e_{ij} n_j \tau_i \\ &= \frac{\mu}{1+(h')^2} \begin{bmatrix} 1 & h' \end{bmatrix} \begin{bmatrix} e_{11} & e_{12} \\ e_{21} & e_{22} \end{bmatrix} \begin{bmatrix} -h' \\ 1 \end{bmatrix} \\ &= \frac{\mu}{1+(h')^2} \begin{bmatrix} 1 & h' \end{bmatrix} \begin{bmatrix} -h'e_{11} + e_{12} \\ -h'e_{21} + e_{22} \end{bmatrix} \\ &= \frac{\mu}{1+(h')^2} (-h'e_{11} + e_{12} + h'(-h'e_{21} + e_{22})) \\ &= \frac{\mu}{1+(h')^2} (h'(e_{22} - e_{11}) + e_{12}(1 - (h')^2)). \end{aligned} \tag{F.11}$$

Our strain tensor components, for a general 2D flow, are

$$\begin{aligned} e_{11} &= \frac{\partial u}{\partial x} \\ e_{22} &= \frac{\partial v}{\partial y} \\ e_{12} &= \frac{1}{2} \left(\frac{\partial v}{\partial x} + \frac{\partial u}{\partial y} \right). \end{aligned} \quad (\text{F.12})$$

So, a zero tangential traction vector component at the interface requires

$$0 = h' \left(\left(\frac{\partial v}{\partial y} - \frac{\partial u}{\partial x} \right) + \frac{1}{2} \left(\frac{\partial v}{\partial x} + \frac{\partial u}{\partial y} \right) \Big|_{y=h} \right) (1 - (h')^2). \quad (\text{F.13})$$

What is the normal component of the traction vector at the interface? We can calculate

$$\begin{aligned} \mathbf{t} \cdot \hat{\mathbf{n}} &= -p \hat{\mathbf{n}} \cdot \hat{\mathbf{n}} + \mu \mathbf{e}_i e_{ij} n_j n_i \\ &= -p + \frac{\mu}{1 + (h')^2} \begin{bmatrix} -h' & 1 \end{bmatrix} \begin{bmatrix} -h' e_{11} + e_{12} \\ -h' e_{21} + e_{22} \end{bmatrix} \\ &= -p + \frac{\mu}{1 + (h')^2} (-h'(-h' e_{11} + e_{12}) - h' e_{21} + e_{22}) \\ &= -p + \frac{\mu}{1 + (h')^2} (-2h' e_{12} + (h')^2 e_{11} + e_{22}). \end{aligned} \quad (\text{F.14})$$

So this component of the traction vector is

$$\mathbf{t} \cdot \hat{\mathbf{n}} = -p + \frac{\mu}{1 + (h')^2} \left(-h' \left(\frac{\partial v}{\partial x} + \frac{\partial u}{\partial y} \right) + (h')^2 \frac{\partial u}{\partial x} + \frac{\partial v}{\partial y} \right). \quad (\text{F.15})$$

For the purely recilinear flow, with $h' = 0$ and $v = 0$, as a consequence of Navier-Stokes and our assumptions, all but the pressure portion of this component of the traction vector was zero. The force balance equation for the interface was therefore just a matching of the pressure with the external (ie: air) pressure.

In this more general case we have the same thing, but the non-pressure portions of the traction vector are all zero in the medium. Outside of the fluid (in the air say), we have assumed no motion, so this force balance condition becomes

$$\mathbf{t} \cdot \hat{\mathbf{n}}|_{\text{fluid}} = \mathbf{t} \cdot \hat{\mathbf{n}}|_{\text{air}}. \quad (\text{F.16})$$

Again assuming no motion of the air, with air pressure p_A , this is

$$\boxed{-p(x, h) + \frac{\mu}{1 + (h')^2} \left(-h' \left(\frac{\partial v}{\partial x} + \frac{\partial u}{\partial y} \right) + (h')^2 \frac{\partial u}{\partial x} + \frac{\partial v}{\partial y} \right) \Big|_{y=h} = -p_A.}$$

(F.17)

Observe that for the horizontal flow problem, where $h' = 0$ and $v = 0$, this would have been nothing more than a requirement that $p(h) = p_A$, but now that we introduce downwards motion and allow the height to vary, the pressure matching condition becomes a much more complex beastie.

F.4 LAPLACIAN OF PRESSURE AND VORTICITY.

Supposing that we are neglecting the non-linear term of the Navier-Stokes equation. For incompressible steady state flow, without any external forces, we would then have

$$0 = -\nabla p + \mu \nabla^2 \mathbf{u}, \tag{F.18a}$$

$$0 = \nabla \cdot \mathbf{u}. \tag{F.18b}$$

How do we actually solve this beastie?

F.4.1 *Separation of variables?*

Considering this in 2D, assuming no z-dependence, with $\mathbf{u} = \mathbf{u}(x, y) = (u, v)$ we have

$$\begin{aligned} 0 &= -\partial_x p + \mu(\partial_{xx} + \partial_{yy})u \\ 0 &= -\partial_y p + \mu(\partial_{xx} + \partial_{yy})v \\ 0 &= \partial_x u + \partial_y v. \end{aligned} \tag{F.19}$$

Attempting separation of variables seems like something reasonable to try. With

$$\begin{aligned} u &= X(x)Y(y) \\ v &= R(x)S(y) \\ p &= P(x)Q(y) \end{aligned} \tag{F.20}$$

we get

$$\begin{aligned}
 0 &= -P'Q + \mu(X''Y + XY'') \\
 0 &= -PQ' + \mu(R''S + RS'') \\
 0 &= X'Y + RS'.
 \end{aligned} \tag{F.21}$$

I could not find a way to substitute any of these into the other that would allow me to separate them, but perhaps I was not clever enough.

F.4.2 *In terms of vorticity?*

The idea of substituting the zero divergence equation $\nabla \cdot \mathbf{u}$ will clearly lead to something a bit simpler. Treating the Laplacian as a geometric (Clifford) product of two gradients we have

$$\begin{aligned}
 0 &= -\nabla p + \mu \nabla^2 \mathbf{u} \\
 &= -\nabla p + \mu \nabla (\nabla \mathbf{u}) \\
 &= -\nabla p + \mu \nabla (\cancel{\nabla \cdot \mathbf{u}} + \nabla \wedge \mathbf{u}) \\
 &= -\nabla p + \mu \nabla (\nabla \wedge \mathbf{u}) \\
 &= \nabla (-p + \mu \nabla \wedge \mathbf{u}).
 \end{aligned} \tag{F.22}$$

Writing out the vorticity (bivector) in component form, and writing $i = \mathbf{e}_1 \wedge \mathbf{e}_2 = \mathbf{e}_1 \mathbf{e}_2$ for the 2D pseudoscalar, we have

$$\begin{aligned}
 \nabla \wedge \mathbf{u} &= (\mathbf{e}_1 \partial_x + \mathbf{e}_2 \partial_y) \wedge (\mathbf{e}_1 u + \mathbf{e}_2 v) \\
 &= \mathbf{e}_1 \mathbf{e}_2 (\partial_x v - \partial_y u) \\
 &= i (\partial_x v - \partial_y u).
 \end{aligned} \tag{F.23}$$

It seems natural to write

$$\Theta = \partial_x v - \partial_y u, \tag{F.24}$$

so that Navier-Stokes takes the form

$$0 = \nabla(-p + i\mu\Theta). \tag{F.25}$$

Operating on this from the left with another gradient we find that this combination of pressure and vorticity must satisfy the following multivector Laplacian equation

$$0 = \nabla^2(-p + i\mu\Theta). \tag{F.26}$$

However, note that ∇^2 is a scalar operator, and this zero identity has both scalar and pure bivector components. Both must separately equal zero

$$0 = \nabla^2 p, \quad (\text{F.27a})$$

$$0 = \nabla^2 \Theta. \quad (\text{F.27b})$$

Note that we can obtain eq. (F.27) much more directly, if we know that is what we want to do. Just operate on eq. (F.18a) with the gradient from the left right off the bat. We find

$$\begin{aligned} 0 &= -\nabla^2 p + \mu \nabla^3 \mathbf{u} \\ &= -\nabla^2 p + \mu \nabla^2 (\nabla \mathbf{u}) \\ &= -\nabla^2 p + \mu \nabla^2 (\nabla \wedge \mathbf{u}). \end{aligned} \quad (\text{F.28})$$

Again, we have a multivector equation scalar and bivector parts, that must separately equal zero. With the magnitude of the vorticity Θ given by eq. (F.24), we once again obtain eq. (F.27). This can be done in plain old vector algebra as well by operating on the left not by the gradient, but separately with a divergence and curl operator.

F.4.3 *Pressure and vorticity equations with the non-linear term retained.*

If we add back in our body force, and assume that it is constant (i.e. gravity), then this this will get killed with the application of the gradient. We will still end up with one Laplacian for pressure, and one for vorticity. That is not the case for the inertial $(\mathbf{u} \cdot \nabla)\mathbf{u}$ term of Navier-Stokes. Let us take the divergence and curl of this and see how we have to modify the Laplacian equations above.

Starting with the divergence, with summation implied over repeated indices, we have

$$\begin{aligned} \nabla \cdot ((\mathbf{u} \cdot \nabla)\mathbf{u}) &= \partial_k (\mathbf{u} \cdot \nabla u_k) \\ &= \partial_k (u_m \partial_m u_k) \\ &= (\partial_k u_m) (\partial_m u_k) + u_m \partial_m \partial_k u_k \\ &= \sum_k (\partial_k u_k)^2 + \sum_{k \neq m} (\partial_k u_m) (\partial_m u_k) + (\mathbf{u} \cdot \nabla) (\nabla \cdot \mathbf{u}). \end{aligned}$$

$$(F.29)$$

So we have

$$\nabla \cdot ((\mathbf{u} \cdot \nabla) \mathbf{u}) = \sum_k (\partial_k u_k)^2 + 2 \sum_{k < m} (\partial_k u_m)(\partial_m u_k) + (\mathbf{u} \cdot \nabla)(\nabla \cdot \mathbf{u}). \quad (F.30)$$

We are working with the $\nabla \cdot \mathbf{u} = 0$ incompressibility assumption so we kill off the last term. Our velocity ends up introducing a non-homogeneous forcing term to the Laplacian pressure equation and we have got something trickier to solve

$$\rho \sum_k (\partial_k u_k)^2 + 2\rho \sum_{k < m} (\partial_k u_m)(\partial_m u_k) = -\nabla^2 p. \quad (F.31)$$

Now let us see how our vorticity Laplacian needs to be modified. Taking the curl of the impulsive term we have

$$\begin{aligned} \nabla \wedge ((\mathbf{u} \cdot \nabla) \mathbf{u}) &= \mathbf{e}_k \partial_k \wedge (u_m \partial_m u_n \mathbf{e}_n) \\ &= (\mathbf{e}_k \wedge \mathbf{e}_n) \partial_k (u_m \partial_m u_n) \\ &= (\mathbf{e}_k \wedge \mathbf{e}_n) ((\partial_k u_m)(\partial_m u_n) + u_m \partial_m \partial_k u_n) \\ &= (\mathbf{e}_k \wedge \mathbf{e}_n) ((\partial_k u_m)(\partial_m u_n) + (\mathbf{u} \cdot \nabla) \partial_k u_n). \end{aligned} \quad (F.32)$$

So we have

$$\nabla \wedge ((\mathbf{u} \cdot \nabla) \mathbf{u}) = (\nabla u_m) \wedge (\partial_m \mathbf{u}) + (\mathbf{u} \cdot \nabla)(\nabla \wedge \mathbf{u}). \quad (F.33)$$

Putting things back together, our vorticity equation is

$$\rho (\nabla u_m) \wedge (\partial_m \mathbf{u}) + \rho (\mathbf{u} \cdot \nabla)(\nabla \wedge \mathbf{u}) = \mu \nabla^2 (\nabla \wedge \mathbf{u}). \quad (F.34)$$

Or, with

$$\boldsymbol{\Omega} = \nabla \wedge \mathbf{u}, \quad (F.35)$$

this is

$$(\nabla u_m) \wedge (\partial_m \mathbf{u}) + (\mathbf{u} \cdot \nabla) \boldsymbol{\Omega} = \nu \nabla^2 \boldsymbol{\Omega}. \quad (F.36)$$

It is this and eq. (F.31) that we really have to solve. Before moving on, let us write out all the non-boundary condition equations in

coordinate form for the 2D case that we are interested in here. We have

$$\rho \left(\left(\frac{\partial u}{\partial x} \right)^2 + \left(\frac{\partial u}{\partial y} \right)^2 + 2 \frac{\partial u}{\partial y} \frac{\partial v}{\partial x} \right) = -\nabla^2 p, \quad (\text{F.37a})$$

$$2 \left(\frac{\partial u}{\partial x} \frac{\partial v}{\partial y} + \frac{\partial v}{\partial x} \frac{\partial v}{\partial y} \right) + \left(u \frac{\partial}{\partial x} + v \frac{\partial}{\partial y} \right) \Theta = \nu \nabla^2 \Theta, \quad (\text{F.37b})$$

$$\Theta = \frac{\partial v}{\partial x} - \frac{\partial u}{\partial y}. \quad (\text{F.37c})$$

Our solution has to satisfy these equations, as well as still satisfying the original Navier-Stokes system eq. (F.2) that includes our gravitational term, and also has to satisfy both of our boundary value constraints eq. (F.13), eq. (F.17), and have $u(x, 0) = v(x, 0) = 0$. Wow, what a mess! And this is all just the steady state problem. Imagine adding time into the mix too!

F.4.4 *Reworking slightly.*

In §40-2 [4], the identity

$$(\mathbf{u} \cdot \nabla) \mathbf{u} = (\nabla \times \mathbf{u}) \times \mathbf{u} + \frac{1}{2} \nabla (\mathbf{u} \cdot \mathbf{u}), \quad (\text{F.38})$$

is used to put the vorticity equation into a form with one additional portion expressed as a gradient. This is a superior way to handle the inertial term because the curl of that gradient is then killed off.

I have expressed the curl as a wedge product, and not a cross product (either works since they related by a constant duality transformation). With the wedge product the identity eq. (F.38) has different signs. That is

$$\begin{aligned} \mathbf{u} \cdot (\nabla \wedge \mathbf{u}) &= (\mathbf{u} \cdot \nabla) \mathbf{u} - \nabla' (\mathbf{u}' \cdot \mathbf{u}) \\ &= (\mathbf{u} \cdot \nabla) \mathbf{u} - \frac{1}{2} \nabla (\mathbf{u} \cdot \mathbf{u}). \end{aligned} \quad (\text{F.39})$$

Here I have used the Hestenes overdot notation [8] to mark the operational range of the gradient ∇ (i.e. indicating that the gradient acts only on one of the \mathbf{u} terms initially). That gives us

$$(\mathbf{u} \cdot \nabla) \mathbf{u} = \mathbf{u} \cdot (\nabla \wedge \mathbf{u}) + \frac{1}{2} \nabla (\mathbf{u} \cdot \mathbf{u}). \quad (\text{F.40})$$

Navier-Stokes (for incompressible flows) now takes the form

$$\frac{\partial \mathbf{u}}{\partial t} + \mathbf{u} \cdot (\nabla \wedge \mathbf{u}) = -\nabla \left(\frac{p}{\rho} + \frac{1}{2} \mathbf{u}^2 + \phi \right) + \nu \nabla^2 \mathbf{u}, \quad (\text{F.41})$$

where in our problem we have killed the time dependence and have

$$\phi = -g(x \sin \alpha, -y \cos \alpha). \quad (\text{F.42})$$

The divergence of $\mathbf{u} \cdot (\nabla \wedge \mathbf{u})$ unfortunately is not zero. For exposition purposes, let us write this out explicitly as a function of the vorticity components

$$\Omega_{rk} = \partial_r u_k - \partial_k u_r. \quad (\text{F.43})$$

Expanding out that divergence we have

$$\begin{aligned} \nabla \cdot (\mathbf{u} \cdot (\nabla \wedge \mathbf{u})) &= \nabla \cdot (u_r \partial_s u_t \mathbf{e}_r \cdot (\mathbf{e}_s \wedge \mathbf{e}_t)) \\ &= \nabla \cdot (u_r \partial_s u_t (\delta_{rs} \mathbf{e}_t - \delta_{rt} \mathbf{e}_s)) \\ &= \partial_k (u_r \partial_s u_k \delta_{rs} - u_r \partial_k u_t \delta_{rt}) \\ &= \partial_k (u_r (\partial_r u_k - \partial_k u_r)), \end{aligned} \quad (\text{F.44})$$

or

$$\nabla \cdot (\mathbf{u} \cdot (\nabla \wedge \mathbf{u})) = \partial_k (u_r \Omega_{rk}). \quad (\text{F.45})$$

Let us also, for exposition, expand out the curl of this remaining non-linear term in coordinates. Being a bit smarter this time, we can avoid expressing Ω in terms of ∇ and \mathbf{u} and leave it as a bivector explicitly. We have

$$\begin{aligned} \nabla \wedge (\mathbf{u} \cdot \Omega) &= \frac{1}{2} \nabla \wedge (u_m \Omega_{ab} \mathbf{e}_m \cdot (\mathbf{e}_a \wedge \mathbf{e}_b)) \\ &= \frac{1}{2} \nabla \wedge (u_m \Omega_{ab} (\delta_{ma} \mathbf{e}_b - \delta_{mb} \mathbf{e}_a)) \\ &= \frac{1}{2} \nabla \wedge (u_a \Omega_{ab} \mathbf{e}_b - u_b \Omega_{ab} \mathbf{e}_a) \\ &= \nabla \wedge (u_a \Omega_{ab} \mathbf{e}_b). \end{aligned} \quad (\text{F.46})$$

This is

$$\nabla \wedge (\mathbf{u} \cdot \Omega) = \partial_r (u_a \Omega_{ak}) \mathbf{e}_r \wedge \mathbf{e}_k. \quad (\text{F.47})$$

The Navier-Stokes equations are now recast in terms of vorticity as

$$\nabla \cdot (\mathbf{u} \wedge \Omega) = -\nabla^2 \left(\frac{p}{\rho} + \frac{1}{2} \mathbf{u}^2 + \phi \right), \quad (\text{F.48a})$$

$$\frac{\partial \Omega}{\partial t} + \nabla \wedge (\mathbf{u} \cdot \Omega) = \nu \nabla^2 \Omega, \quad (\text{F.48b})$$

$$\Omega = \nabla \wedge \mathbf{u}, \quad (\text{F.48c})$$

$$\nabla \cdot \mathbf{u} = 0, \quad (\text{F.48d})$$

Having restated things with the $\nabla \mathbf{u}^2$ term moved to the RHS, let us also now write out eq. (F.48a) and eq. (F.48b) in coordinate form (we want this for the 2D case). This is

$$\partial_b (u_a \Omega_{ab}) = -\nabla^2 \left(\frac{p}{\rho} + \frac{1}{2} \mathbf{u}^2 + \phi \right), \quad (\text{F.49a})$$

$$\frac{\partial \Omega_{mn}}{\partial t} + \partial_m (u_a \Omega_{an}) - \partial_n (u_a \Omega_{am}) = \nu \nabla^2 \Omega_{mn}. \quad (\text{F.49b})$$

For our problem where we have only u_1 and u_2 components, and any ∂_3 operations are zero, we find

$$\begin{aligned} \partial_b (u_a \Omega_{ab}) &= \partial_2 (u_1 \Omega_{12}) + \partial_1 (u_2 \Omega_{21}) \\ &= (\partial_2 u_1 - \partial_1 u_2) \Omega_{12} + u_1 \partial_2 \Omega_{12} - u_2 \partial_1 \Omega_{12} \\ &= -\Omega_{12}^2 + (u_1 \partial_2 - u_2 \partial_1) \Omega_{12} \\ &= -\Omega_{12}^2 - i \cdot (\mathbf{u} \wedge \nabla) \Omega_{12}, \end{aligned} \quad (\text{F.50})$$

and

$$\begin{aligned} \partial_1 (u_a \Omega_{a2}) - \partial_2 (u_a \Omega_{a1}) &= \partial_1 (u_1 \Omega_{12}) - \partial_2 (u_2 \Omega_{21}) \\ &= \partial_1 (u_1 \Omega_{12}) + \partial_2 (u_2 \Omega_{12}) \\ &= (\partial_1 u_1 + \partial_2 u_2) \Omega_{12} + (u_1 \partial_1 + u_2 \partial_2) \Omega_{12} \\ &= (\mathbf{u} \cdot \nabla) \Omega_{12}. \end{aligned} \quad (\text{F.51})$$

So we have

$$\Omega_{12}^2 + i \cdot (\mathbf{u} \wedge \nabla) \Omega_{12} = \nabla^2 \left(\frac{p}{\rho} + \frac{1}{2} \mathbf{u}^2 + \phi \right), \quad (\text{F.52a})$$

$$\frac{\partial \Omega_{12}}{\partial t} + (\mathbf{u} \cdot \nabla) \Omega_{12} = \nu \nabla^2 \Omega_{12}. \quad (\text{F.52b})$$

Here I have used $i = \mathbf{e}_1 \mathbf{e}_2$ again, so that the pair of differential operators on the LHS of the respective equations above are

$$\begin{aligned} i \cdot (\mathbf{u} \wedge \nabla) &= -u_1 \partial_2 + u_2 \partial_1 \\ \mathbf{u} \cdot \nabla &= u_1 \partial_1 + u_2 \partial_2. \end{aligned} \quad (\text{F.53})$$

Note that since $\nabla^2 \phi$ could equal zero (as in our problem) we will likely have additional work to ensure that any solution that we find to this set of equations is also still a solution to our original first order Navier-Stokes equation.

F.5 NOW WHAT?

The strategy that I had thought to attempt to tackle this problem, when I had left it like eq. (F.37) was something along the following lines

- First ignore the non-linear terms. Find solutions for the homogeneous vorticity and pressure Laplacian equations that satisfy our boundary value conditions, and use that to find a first solution for $h(x)$.
- Use this to solve for u and v from the vorticity.

However, after reworking it using the identity found in Feynman's dry water chapter, I think it is best not to try to solve it yet, and study some more first. I have a feeling that there are likely more such techniques that have been developed that will be useful to know before I try to plow my way through things.

Regardless, it is interesting to see just how tricky the equations of motion become when one does not make unrealistic assumptions. I have a feeling that to actually attempt this specific problem, I may very well need a computer and numerical techniques.

G

INFINITE STIRRED COFFEE.

G.1 MOTIVATION.

Having tackled the problem of the spin down of a bottomless cup of coffee, lets try setting up the harder problem with a non-infinite cup. It turns out that this is a lot harder. Even the steady state solution requires a superposition of Bessel functions (whereas we only had that in the bottomless problem when we tried to find the time evolution after ceasing the stirring).

I can find the form of the solution, but do not know how to actually apply the boundary value constraints. I also find the no-slip constraints themselves become problematic, because they lead to an inconsistency at the point of contact of a moving and a static interface. Before continuing, I need to find out how to deal with that inconsistency.

G.2 NAVIER-STOKES FOR THE PROBLEM.

Working in cylindrical coordinates is the only sensible option. Let us look first at the steady state problem, with the cup being stirred at a constant rate with the unrealistic rotating cylinder stir stick used previously. We will assume an azimuthal velocity profile

$$\mathbf{u} = u(r, z, t)\hat{\phi}. \quad (\text{G.1})$$

Let us first verify that this satisfies our incompressible condition

$$\begin{aligned} \nabla \cdot \mathbf{u} &= \left(\hat{r}\partial_r + \frac{\hat{\phi}}{r}\partial_\phi + \hat{z}\partial_z \right) \cdot (u\hat{\phi}) \\ &= \cancel{\hat{r}} \cdot \cancel{\hat{\phi}}\partial_r u + \frac{\hat{\phi}}{r} \cdot (u\partial_\phi \hat{\phi} + \hat{\phi}\partial_\phi u) + \cancel{\hat{z}} \cdot \cancel{\hat{\phi}}\partial_z u. \end{aligned} \quad (\text{G.2})$$

The only term that survives is the $\partial_\phi \hat{\phi} = -\hat{r}$ but that is perpendicular to $\hat{\phi}$ so we have $0 = \nabla \cdot \mathbf{u}$ as desired. This leaves us with

$$\begin{aligned} \frac{u}{r} \partial_\phi (u \hat{\phi}) &= -\frac{1}{\rho} \left(\hat{r} \partial_r + \frac{\hat{\phi}}{r} \partial_\phi + \hat{z} \partial_z \right) p \\ &+ \nu \left(\frac{1}{r} \partial_r (r \partial_r) + \frac{1}{r^2} \partial_{\phi\phi} + \partial_{zz} \right) u \hat{\phi} + \mathbf{g}. \end{aligned} \quad (\text{G.3})$$

Splitting into $\hat{\phi}, \hat{r}, \hat{z}$ coordinates respectively we have

$$0 = -\frac{1}{r\rho} \partial_\phi p + \nu \left(\frac{1}{r} \partial_r (r \partial_r u) - \frac{u}{r^2} + \partial_{zz} u \right), \quad (\text{G.4a})$$

$$-\frac{u^2}{r} = -\frac{1}{\rho} \partial_r p, \quad (\text{G.4b})$$

$$0 = -\frac{1}{\rho} \partial_z p - g. \quad (\text{G.4c})$$

Demanding a symmetrical solution kills off the pressure term in eq. (G.4a), and we can proceed with separation of variables to find the allowable solutions for the velocity before imposing our boundary value conditions. With $u = R(r)Z(z)$ we have

$$\frac{1}{rR} (R' + rR'') - \frac{1}{r^2} = -\frac{Z''}{Z} = -\frac{1}{a^2} = \frac{1}{b^2}. \quad (\text{G.5})$$

Should we pick a negative or a positive constant here (ie: trig or hyperbolic functions for Z)? Allowing for both temporarily, we find for R

$$0 = rR' + r^2R'' + R \left(-1 + \frac{r^2}{a^2} \right), \quad (\text{G.6a})$$

$$0 = rR' + r^2R'' + R \left(-1 - \frac{r^2}{b^2} \right). \quad (\text{G.6b})$$

Using Mathematica ([coffeeCupWithBottom.cdf](#)) to look up the solutions, we find that this was a Bessel equation with solutions

$$\bar{R}(r) \in \text{span}\{J_1(r/a), Y_1(r/a)\}, \quad (\text{G.7a})$$

$$R(r) \in \text{span}\{J_1(ir/b), Y_1(ir/b)\}. \quad (\text{G.7b})$$

However, the second set are not real valued for $r > 0$. This means we want the hyperbolic solutions for Z . Because we also have a boundary value constrain of $u = 0$ on the bottom of the cup, we can pick only hyperbolic sine solutions. As before, we will “stir” the coffee with a cylinder at radius s (with cup radius R), our solution has the form

$$u(r, z, 0) = \begin{cases} s\Omega \sum C_a J_1(r/a) \sinh(z/a) & r < s \\ s\Omega \sum (D_a J_1(r/a) + E_a Y_1(r/a)) \sinh(z/a) & r \in [s, R]. \end{cases} \quad (\text{G.8})$$

Observe that, regardless of a we have $u(0, z, 0) = 0$ because $J_1(0) = 0$. We also can not scale a as λ_i/s (where λ_i are the zeros of J_1) when the stirring is not at the edge since we need $u(s, z, 0) = \Omega s$. That suggests that we probably want to write our system as

$$u(r, z, 0) = \begin{cases} s\Omega \sum C_i J_1(\lambda_i r/R) \sinh(\lambda_i z/R) & r < s \\ s\Omega \sum (D_i J_1(\lambda_i r/R) + E_i Y_1(\lambda_i r/R)) \sinh(\lambda_i z/R) & r \in [s, R]. \end{cases} \quad (\text{G.9})$$

The boundary value constraints of $u(r = s) = \Omega s$ and $u(r = R) = 0$ require the solution of

$$1 = \sum C_i J_1(\lambda_i s/R) \sinh(\lambda_i z/R), \quad (\text{G.10a})$$

$$1 = \sum (D_i J_1(\lambda_i s/R) + E_i Y_1(\lambda_i s/R)) \sinh(\lambda_i z/R), \quad (\text{G.10b})$$

$$0 = \sum E_i Y_1(\lambda_i) \sinh(\lambda_i z/R). \quad (\text{G.10c})$$

We know how to solve a system like eq. (G.10a) if we did not have the \sinh term in the mix. Can we look for a numerical (least squares?) solution to this more general problem. Will it be possible to find something that is a good fit regardless of the value of z ?

We have other troubles too. We can not simultaneously satisfy the boundary value condition of $u(s, z) = \Omega s$ and also $u(s, 0) = 0$. Should we attempt something like a least squares solution and start going near $z = 0$ the small sinh values near there will start forcing the C_i 's arbitrarily high.

We have to somehow modify the no-slip condition so that when we have a moving interface in contact with a static interface we somehow deal with the fact that the no-slip constraints cannot simultaneously require the velocity to match both the moving and static interfaces at that point of contact.

G.3 BASE OF CUP NO-SLIP TROUBLES.

We have just found the functional form for an azimuthal flow that has z -axis dependence. Attempting to apply the no-slip boundary value condition for our mixing device got us into trouble, since this simultaneously require zero and non-zero velocity at the point of contact of the mixing interface and the bottom of the vessel (i.e. where the stir stick contacts the bottom of the cup). We can avoid this issue by constraining the mixing to only occur above the bottom of the cup, and then look at the flow that this induces below the mixing point.

Let us attempt to solve this new simpler boundary value problem. We will position the mixing cylinder at a height d above the bottom of the cup, and set the radius of that inner cylinder to s as before, with the mixing occurring at an angular velocity of Ω . We now want apply these boundary value constrains to the velocity function we have found for the steady state problem. Provided $z < d$, this will have the form

$$u(r, z, 0) = s\Omega \sum C_i J_1(\lambda_i r/R) \sinh(\lambda_i z/R), \quad (\text{G.11})$$

where λ_i are the zeros of the order one Bessel function J_1 . Observe that our boundary value conditions of $u(R, z, 0) = 0$ and $u(r, 0, 0) = 0$ are automatically satisfied. Note that because of the $u(R, z, 0) = 0$ equality here, this form of solution is no good if we are mixing at the edge of the cup, so we require $s \neq R$.

Our remaining boundary value condition $u(s, d, 0) = s\Omega$, means that we have to solve

$$1 = \sum C_i J_1(\lambda_i s/R) \sinh(\lambda_i d/R). \quad (\text{G.12})$$

Having had the same sort of problem in our steady state bottomless coffee problem, we know how to solve this

$$C_i \sinh(\lambda_i d/R) = \frac{\int_0^1 w J_1(\lambda_i w) dw}{\int_0^1 w J_1^2(\lambda_i w) dw}. \quad (\text{G.13})$$

So we find that below the point of stirring ($z = d$), our steady state solution for the velocity should be

$$\mathbf{u}(r, z, 0) = s\Omega \hat{\phi} \sum_{i=1}^{\infty} \frac{\int_0^1 w J_1(\lambda_i w) dw}{\int_0^1 w J_1^2(\lambda_i w) dw} J_1(\lambda_i r/R) \frac{\sinh(\lambda_i z/R)}{\sinh(\lambda_i d/R)}. \quad (\text{G.14})$$

For a cup size of $R = 5\text{cm}$, stir radius of $s = 3\text{cm}$, stir depth $d = 2\text{cm}$, and angular velocity $\Omega = 2\pi\text{rad/s}$, we can compute ([coffeeCupWithBottom.cdf](#)) some terms of this series

$$\begin{aligned} u(r, z, 0) = & 27.1119 J_1(7.66341r) \sinh(7.66341z) \\ & - 3.42819 J_1(14.0312r) \sinh(14.0312z) \\ & + 4.97807 J_1(20.3469r) \sinh(20.3469z) \\ & - 1.53542 J_1(26.6474r) \sinh(26.6474z) + \dots \end{aligned} \quad (\text{G.15})$$

We can plot this velocity field as in fig. [G.1](#), but it is hard to see the radial dependence. The radial dependence of the magnitude of the velocity can be seen in fig. [G.2](#), which plots $u(r, d, 0)$. We see the zero velocity at the edges of the cup as expected, and once we hit the stir height, matching of stir velocity. An animation showing the variation of the radial velocity profile at various depths up to the stir height is available at <http://youtu.be/BS8XQdXljSk>. Observing this we see that the velocity is dominated by the first term in the Bessel series, essentially just scaled by the hyperbolic sine that multiplies it. It is not clear to me how to compute the velocity profile above the point of lowest stir depth. Let us ignore that for now, and think a bit about the spin down problem.

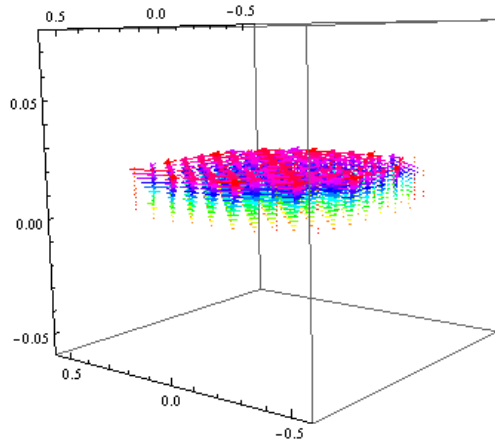

Figure G.1: Vector field plot of the velocity field below the stir depth.

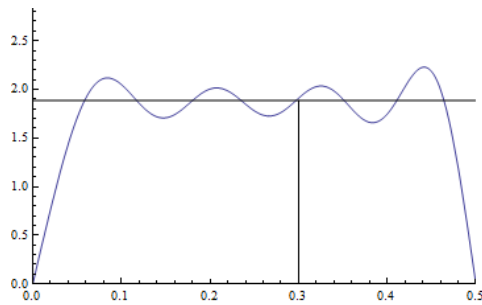

Figure G.2: Radial velocity dependence at the stir height.

G.4 SPIN DOWN BELOW THE STIR POINT.

Let us now consider the time evolution problem when we stop the stirring abruptly at $t = 0$. The $\hat{\phi}$ component of Navier-Stokes becomes

$$\frac{\partial u}{\partial t} = \nu \left(\frac{1}{r} \partial_r (r \partial_r u) - \frac{u}{r^2} + \partial_{zz} u \right), \quad (\text{G.16})$$

with $u = R(r)Z(z)T(t)$ we find

$$\frac{T'}{T} = -\nu \frac{\alpha^2}{R^2} = \nu \left(\frac{1}{rR} (rR')' - \frac{1}{r^2} + \frac{Z''}{Z} \right). \quad (\text{G.17})$$

We have immediately

$$T \propto e^{-\alpha^2 \nu t / R^2}, \quad (\text{G.18})$$

and can insist that we also have

$$\frac{1}{rR} (rR')' - \frac{1}{r^2} = -\frac{\lambda_i^2}{R^2}, \quad (\text{G.19a})$$

$$\frac{Z''}{Z} = \frac{\lambda_i^2}{R^2} - \frac{\alpha^2}{R^2}. \quad (\text{G.19b})$$

Our time dependent solution below the point of stirring is therefore of the form

$$\begin{aligned} u(r, z, t) = s\Omega \sum_{\lambda_i^2 > \alpha^2} c_{i\alpha} J_1(\lambda_i r / R) \sinh \left(\sqrt{\lambda_i^2 - \alpha^2} z / R \right) e^{-\alpha^2 \nu t / R^2} \\ + s\Omega \sum_{\lambda_i^2 < \alpha^2} d_{i\alpha} J_1(\lambda_i r / R) \sin \left(\sqrt{\alpha^2 - \lambda_i^2} z / R \right) e^{-\alpha^2 \nu t / R^2}, \end{aligned} \quad (\text{G.20})$$

with a boundary value condition

$$\begin{aligned} \sum_{i=1}^{\infty} \frac{\int_0^1 w J_1(\lambda_i w) dw}{\int_0^1 w J_1^2(\lambda_i w) dw} J_1(\lambda_i r / R) \frac{\sinh(\lambda_i z / R)}{\sinh(\lambda_i d / R)} \\ = \sum_{\lambda_j^2 > \alpha^2} c_{j\alpha} J_1(\lambda_j r / R) \sinh \left(\sqrt{\lambda_j^2 - \alpha^2} z / R \right) \\ + \sum_{\lambda_j^2 < \alpha^2} d_{j\alpha} J_1(\lambda_j r / R) \sin \left(\sqrt{\alpha^2 - \lambda_j^2} z / R \right). \end{aligned} \quad (\text{G.21})$$

I had like to go back and understand the Sturm Liouville theory in [14] that I used the result from to solve the steady state problem. Thinking about what I have been using, we basically been using a weighted inner product, so that if we are looking for a fit for $x \in [0, 1]$ of

$$\phi(x) = \sum_i c_i J_1(\lambda_i x), \tag{G.22}$$

we have been utilizing a weighted inner product relation of the form

$$\int_0^1 x J_1(\lambda_i x) J_1(\lambda_j x) dx = \delta_{ij} \int_0^1 x J_1^2(\lambda_i x) dx. \tag{G.23}$$

Suppose that we drop the hyperbolic terms above, and insist that

$$\sqrt{\alpha^2 - \lambda_j^2} \frac{d}{R} = 2\pi j, \tag{G.24}$$

or

$$\frac{\alpha^2}{R^2} = \frac{4\pi^2 j^2}{d^2} + \frac{\lambda_j^2}{d^2}, \tag{G.25}$$

leaving us with the hope that we can find $d_j = d_{j\alpha}$ so that for $x, y \in [0, 1]$ we have

$$\sum_{i=1}^{\infty} \frac{\int_0^1 w J_1(\lambda_i w) dw}{\int_0^1 w J_1^2(\lambda_i w) dw} J_1(\lambda_i x) \frac{\sinh(\lambda_i y d / R)}{\sinh(\lambda_i d / R)} = \sum_{j=1}^{\infty} d_j J_1(\lambda_j x) \sin(2\pi j y). \tag{G.26}$$

Observing that

$$\int_0^1 \sin(2\pi j y) \sin(2\pi k y) dy = \frac{1}{2} \delta_{jk}. \tag{G.27}$$

We can multiply both sides by $x J_1(\lambda_k x) \sin(2\pi m y)$ and integrating over the unit square we have

$$\begin{aligned} & \sum_{i=1}^{\infty} \frac{\int_0^1 w J_1(\lambda_i w) dw}{\int_0^1 w J_1^2(\lambda_i w) dw} \\ &= \sum_{j=1}^{\infty} d_j \int_0^1 x J_1(\lambda_j x) J_1(\lambda_k x) dx \int_0^1 \sin(2\pi m y) \sin(2\pi j y) dy. \end{aligned} \tag{G.28}$$

Applying the orthogonality relations we have

$$\begin{aligned} & \sum_{i=1}^{\infty} \frac{\int_0^1 w J_1(\lambda_i w) dw}{\int_0^1 w J_1^2(\lambda_i w) dw} \int_0^1 x J_1^2(\lambda_i x) \delta_{ik} \int_0^1 \sin(2\pi m y) \frac{\sinh(\lambda_i y d/R)}{\sinh(\lambda_i d/R)} \\ &= \sum_{j=1}^{\infty} d_j \int_0^1 x J_1^2(\lambda_j x) dx \delta_{jk} \frac{1}{2} \delta_{mj}, \end{aligned} \quad (\text{G.29})$$

or

$$\int_0^1 w J_1(\lambda_k w) dw \int_0^1 \sin(2\pi k y) \frac{\sinh(\lambda_k y d/R)}{\sinh(\lambda_k d/R)} dy = \frac{1}{2} d_k \int_0^1 x J_1^2(\lambda_k x) dx. \quad (\text{G.30})$$

We have got the same Bessel integral on both sides leaving us with

$$d_k = 2 \int_0^1 \sin(2\pi k y) \frac{\sinh(\lambda_k y d/R)}{\sinh(\lambda_k d/R)} dy = \frac{4\pi k (-1)^{k+1} \sinh\left(\frac{d\lambda_k}{R}\right)}{\frac{d^2 \lambda_k^2}{R^2} + 4k^2 \pi^2}. \quad (\text{G.31})$$

Putting all the pieces together we have for the spin down of the fluid below the stir height for $t \geq 0$.

$$\begin{aligned} \mathbf{u}(r, z, t) = \frac{\Omega s}{\pi} \hat{\phi} \sum_{j=1}^{\infty} (-1)^{j+1} \frac{j}{\frac{d^2 \lambda_j^2}{4R^2 \pi^2} + j^2} \sinh\left(\frac{d\lambda_j}{R}\right) \exp\left(-\left(\frac{\lambda_j^2}{R^2} + \frac{4\pi^2 j^2}{d^2}\right) vt\right) J_1\left(\frac{\lambda_j r}{R}\right) \sin\left(\frac{2\pi j z}{d}\right). \end{aligned} \quad (\text{G.32})$$

It is interesting that we end up with products of the orthonormal Bessel and trig functions when we started with a requirement for Bessel times hyperbolic trig functions. We can likely utilize a similar Fourier decomposition of the hyperbolic trig functions to solve the steady state problem above the stir point, then solve for all our Fourier coefficients using this technique. That will obviously be a harder problem, but one that looks at least feasible. Regardless, we have to start at the bottom of the cup and work our boundary value conditions up from there.

We have a result that appears to validate the claim in [2] about the importance of the bottom of the cup in this problem. Let us look at the magnitude of the viscous boundary layer term and see if we can estimate approximately when the spin down is mostly complete.

Let us also plot this function and see that it matches up with what is we have previously computed for the steady state problem.

Plotting this gave me something that looked completely bogus. Going back and looking where things went wrong, I see that even my steady state “solution” is wrong. The problems start at eq. (G.12) where we have matched values at a single point $r = s$, and then integrated over s as if it was a variable. Also later in my spin down work, I think I am too loose with my deltas, and that is probably wrong too. Back to the drawing board.

NOTE: constructing the Fourier fit for a sinh curve I see that sine, cosine and a constant term is required. Have to rework with this in mind. Can not just pick the sine function so that we match $u = 0$ at $z = 0$, but need to match at all z . Is that constant term going to be trouble?

H

MATHEMATICA NOTEBOOKS.

These Mathematica notebooks, some just trivial ones used to generate figures, others more elaborate, and perhaps some even polished, can be found in

<https://github.com/peeterjoot/mathematica/tree/master/phy454/>.

The free **Wolfram CDF player**, is capable of read-only viewing these notebooks to some extent.

Files saved explicitly as CDF have interactive content that can be explored with the CDF player.

- Jan 17, 2012 [strainTensorCylindrical.cdf](#)

Compute the cylindrical strain tensor components to second order.

Using the notation package for the first time to get results that make the mathematica notebook text intelligible as well as the final result.

Also use the `Collect[]` function for the first time to group the results according to the differential products of interest.

- Jan 17, 2012 [strainTensorSphericalColumnVectors.cdf](#)

Same as `strainTensorSpherical`, but I didn't pre-compute the line element differentials myself, instead letting mathematica do the grunt work.

Note that in this version, I specified the definitions of `rcap`, `thetacap`, and `phicap` manually, but had some commented out code to verify that I had this right.

This notebook was left using `Collect` instead of `coefficient`, so the collected factors do not match the text equation results without additional manual comparison work.

Also use this to output the column matrices for `rcap`, `thetacap` and `phicap` and `drcap/dt`.

- Jan 21, 2012 [strainTensorSpherical.cdf](#)

Like strainTensorCylindrical but for spherical coordinates.

Here I used Coefficient instead of Collect so that I could factor out the additional portions of the area element differentials for constancy and comparison with the Landau and Lifshitz equation.

- Feb 3, 2012 [continuumProblemSet1Q1.cdf](#)

PHY454. Problem set 1.

Final grunt calculation.

Mathematica features used: 3×3 matrix, IdentityMatrix, Tr (trace), MatrixForm, evaluate last expression.

- Feb 4, 2012 [continuumProblemSet1Q2.cdf](#)

PHY454 Problem set 1. Q2.

Confirm the characteristic equation calculated manually.

Find the root, by solving the characteristic equation.

Find the eigenvalues and normalized eigenvectors.

Interesting mathematica functions used: Map which applies operation to list, Normalize, Solve, Table, Total – adding all elements in a list.

- Feb 5, 2012 [continuumProblemSet1Q3.cdf](#)

PHY454 Problem set 1. Q3.

Confirm some manual matrix calculations.

Used Cross product function, and Orthogonalize for Gram-Schmidt like expansion.

- Feb 8, 2012 [continuumProblemSet1Q2animated.cdf](#)

PHY454 Problem set 1. Q2.

Animate the stress tensor associated with the problem, for different points and values of Poisson's ratio.

This generalizes the solution of the problem since answers visually whether the point is under expansion (blue arrow) or under compression (red arrow) at each point in space.

Mathematica manipulate sliders are used to select the spatial points and the value of Poisson's ratio.

Used a number of new (for me) mathematica features: Table, Arrow, If, Part, multiple colors in Graphics3D, DiagonalMatrix, Diagonal (select diagonal into list), Tr (not Trace!), Map, Eigenvalues, Eigenvectors, and in a later version Eigensystem to replace the last two.

The code has links to various stackexchange questions for this notebook. There's an answer on scaling that's incorporated into the Graphics3D options. One more mathematica stackexchange question answered on this little notebook which motivated the Dynamic and DynamicModule calls now here, and one more that drove the change to use Eigensystem.

- Feb 12, 2012 [partErrorTestStandalone2D.cdf](#)

Based on phy454continuumProblemSet1Q2animated.cdf, with most stuff stripped out to ask about the errors on initial load in mathematica.stackexchange question.

- Mar 3, 2012 [twoLayerInclinedFlowDifferentDensities.cdf](#)

Plug in some numbers for the viscosities and densities for the inclined fluid flow down a plane problem. Insertion of an air layer above the water ends up with the air speed humongous! Steady state not realistic? What are the length scales required for steady state?

New mathematica functions used: WolframAlpha, ChemicalData.

- Mar 4, 2012 [twoLayerInclinedFlowDifferentDensitiesTheCalculation.cdf](#)

Redo the hand calculation in twoLayerInclinedFlowDifferentDensities.tex completely in mathematica and verify the results. I did it right.

Notable mathematica functions used: Do, Solve, Collect, ExpandAll.

- Mar 13, 2012 [continuumProblemSet2Fig1r2.cdf](#)

Generate figures for continuum mechanics problem set II figure 1. Using Show and ParametricPlot for the first time. First version used Wacom tablet and graphics drawing options to put in arrows. Text labels later added with Inkscape latex-pdf. Later version used Array of Arrows to draw vector field. Looks much better.

- Mar 14, 2012 [continuumProblemSet2Fig3.cdf](#)
Figure3 for continuum mechanics problem set II. Used ChemicalData again and used Piecewise.
- Mar 14, 2012 [problemSetIIQ3exactSolution.cdf](#)
Exact solution to Q3 velocities. Return to this and plot it later.
- Mar 16, 2012 [continuumL17Figures.cdf](#)
erf Plot. Using AxesLabel
- Mar 22, 2012 [problemSetIIQ3PlotWithManipulate.cdf](#)
Plotting the two layer constant pressure gradient solution.
- Mar 29, 2012 [continuumL20Figures.cdf](#)
Generate figures for lecture 20 notes.
- Mar 31, 2012 [channelFlowWithStepPressureGradient.cdf](#)
Animation for the time evolution of a channel flow due to constant pressure gradient turned on at an initial time for fluid at rest before that.
- Apr 4, 2012 [continuumL22Figures.cdf](#)
Figure for last lecture. Defined a rectGraphic function, just to create a drawing area. Toss that in a mathematica module file to learn how to make one.
- Apr 11, 2012 [couetteFlow.cdf](#)
Plot the Couette flow solutions. This is by far my coolest attempt to use Mathematica to do visualization so far. The velocity field is plotted in the appropriate circular contours, albeit without arrows and without an envelope with the contours of the field profile. New tricks learned for this notebook

include the use of Slider, Dynamic, and RadioButtonBar. Row and Column were used to group the sliders and labels and resulting plots. I coded up a really cool viscosity and density selector too, but that did not get used here so I commented it out and disabled the initialization cell that I had put in for the ChemicalData lookup. Things were also coded in a nice clean fashion so that I could use one helper function to generate both the Manipulate like controls and also the table that I used to save an animation for my pdf file with the original calculations.

- Apr 14, 2012 [twoCylinders.cdf](#)
Plot the flow between two infinite cylinders. Mathematica coding style is getting nicer. This has no prologue attempting to be self contained with a nice text description ... too much work to do that in Mathematica instead of Latex. Used Manipulate to generate an animation that includes the sliders. Tried embedding this in the associated pdf, but ffmpeg cant handle it, and I do not know how to coerce it to do so.
- Apr 15, 2012 [twoCylinders3D.cdf](#)
Take the previous calculation and display and do it in 3D instead. Very cool.
- Apr 15, 2012 [demoTemplateTwoCylinders3D.nb](#)
Add some explanatory text, and put in the format required for the wolfram demo upload page.
- Apr 25, 2012 [bottomlessCoffee.cdf](#)
Plot the Bessel function fitting for the spin down of a bottomless coffee cup. Also animate the time evolution of the spin down with a Manipulate slider. As mentioned in the text, this does not match reality too well.
- Apr 25, 2012 [continuumFluidsReview.cdf](#)
The integral for chapter 7, problem 2 of Landau's fluids. Curve for a fluid meniscus up a wall.
- Apr 27, 2012 [coffeeCupWithBottom.cdf](#)

Solving the PDE for the non-bottomless coffee cup problem. Find Bessel functions of order 1. Find the fitting coefficients for stirring above the bottom, in the layer of fluid lower than the stirring. Plot this function, and verify against boundary condition.

INDEX

- Bernoulli's equation, 161
- biaxial stress, 24, 26
- bivector, 302
- boundary layer, 198, 215
- buoyancy force, 156

- Cauchy tetrahedron, 28
- characteristic length, 179
- characteristic velocity, 179
- compatibility condition, 10
- constitutive relation, 2, 33, 67
- curl, 51
- cylindrical coordinates, 10, 15, 257

- diagonalization, 27
- dimensionless form, 184
- displacement, 63

- elastic displacement, 54
- elastic wave, 47, 52

- fluid interface, 73
- Fourier coefficient, 297

- geometric product, 305
- gradient, 51

- Mathematica, 323
- multivector, 305

- Newtonian fluid, 2, 67
- Newtonian material, 31
- no slip, 316
- normal, 73

- p-wave, 48, 54
- phasor, 52
- pressure, 175
- pressure gradient, 158
- pseudoscalar, 305

- radius of curvature, 175
- rectilinear flow, 190
- Reynold's number, 184

- s-wave, 50, 55
- scaling, 179, 183
- strain, 2, 10, 15
- strain tensor, 257, 277
- stress, 2
- surface tension, 175

- tangent, 73
- traction vector, 30, 95, 171

- uniaxial stress, 23, 26, 33

- vector displacement, 92
- viscosity, 198
- volume element, 8
- vorticity, 158, 311

- wedge product, 276, 305

BIBLIOGRAPHY

- [1] M. Abramowitz and I.A. Stegun. *Handbook of mathematical functions with formulas, graphs, and mathematical tables*, volume 55. Dover publications, 1964. (Cited on page 221.)
- [2] D.J. Acheson. *Elementary fluid dynamics*. Oxford University Press, USA, 1990. (Cited on pages 3, 10, 16, 63, 71, 84, 86, 88, 121, 127, 134, 141, 191, 209, 216, 217, 243, 275, and 322.)
- [3] George Keith Batchelor. *An introduction to fluid dynamics*. Cambridge University Press, 1967. (Cited on page 162.)
- [4] R.P. Feynman, R.B. Leighton, and M.L. Sands. *Feynman lectures on physics.[Lectures on physics]*, chapter The flow of dry water. Addison-Wesley Publishing Company. Reading, Massachusetts, 1963. (Cited on page 308.)
- [5] R.P. Feynman, R.B. Leighton, and M.L. Sands. *Feynman lectures on physics.[Lectures on physics]*, chapter Elastic Materials. Addison-Wesley Publishing Company. Reading, Massachusetts, 1963. (Cited on page 31.)
- [6] National Committee for Fluid Mechanics. Surface tension. Youtube. URL <https://youtu.be/MU1mkSnrAzM>. [Online; accessed 07-July-2019]. (Cited on page 174.)
- [7] S. Granger. *Fluid Mechanics*. Dover, New York, 1995. (Cited on pages 174 and 181.)
- [8] D. Hestenes. *New Foundations for Classical Mechanics*. Kluwer Academic Publishers, 1999. (Cited on page 308.)
- [9] EJ Hinch. *Perturbation methods*, volume 6. Cambridge Univ Pr, 1991. (Cited on page 235.)
- [10] Peeter Joot. Two cylinders. Youtube. URL <https://www.youtube.com/watch?v=0iJT0pWx7L8>. [Online; accessed 07-July-2019]. (Cited on page 153.)

- [11] Peeter Joot. *3D Velocity Profile for Flow between Two Cylinders*, 2012. URL <http://demonstrations.wolfram.com/3DVelocityProfileForFlowBetweenTwoCylinders/>. [Online; accessed 26-Apr-2012]. (Cited on page 153.)
- [12] L.D. Landau and E.M. Lifshitz. *A Course in Theoretical Physics-Fluid Mechanics*. Pergamon Press Ltd., 1987. (Cited on pages 162, 165, 173, 174, 176, 285, 286, and 288.)
- [13] L.D. Landau, EM Lifshitz, JB Sykes, WH Reid, and E.H. Dill. *Theory of Elasticity: Vol. 7 of Course of Theoretical Physics*. 1960. (Cited on pages 3, 6, 10, 16, 21, 31, 39, 47, 48, and 52.)
- [14] H. Sagan. *Boundary and eigenvalue problems in mathematical physics*. Dover Pubns, 1989. (Cited on pages 222 and 320.)
- [15] Eric W. Weisstein. *Thermal Diffusivity*. URL <http://scienceworld.wolfram.com/physics/ThermalDiffusivity.html>. [Online; accessed 29-December-2014]. (Cited on page 186.)
- [16] Wikipedia. *Stokes boundary layer* — *Wikipedia, The Free Encyclopedia*, 2011. URL http://en.wikipedia.org/w/index.php?title=Stokes_boundary_layer&oldid=466077125. [Online; accessed 16-March-2012]. (Cited on page 201.)
- [17] Wikipedia. *Compatibility (mechanics)* — *Wikipedia, The Free Encyclopedia*, 2011. URL [http://en.wikipedia.org/w/index.php?title=Compatibility_\(mechanics\)&oldid=463812965](http://en.wikipedia.org/w/index.php?title=Compatibility_(mechanics)&oldid=463812965). [Online; accessed 23-April-2012]. (Cited on pages 12 and 16.)
- [18] Wikipedia. *Newtonian fluid* — *Wikipedia, The Free Encyclopedia*, 2011. URL http://en.wikipedia.org/w/index.php?title=Newtonian_fluid&oldid=460346447. [Online; accessed 17-March-2012]. (Cited on page 111.)
- [19] Wikipedia. *Rheology* — *Wikipedia, The Free Encyclopedia*, 2011. URL <http://en.wikipedia.org/w/index.php?title=Rheology&oldid=466714610>. [Online; accessed 11-January-2012]. (Cited on page 2.)
- [20] Wikipedia. *Saint-Venant's compatibility condition* — *Wikipedia, The Free Encyclopedia*, 2011. URL <http://>

[//en.wikipedia.org/w/index.php?title=Saint-Venant%27s_compatibility_condition&oldid=436103127](http://en.wikipedia.org/w/index.php?title=Saint-Venant%27s_compatibility_condition&oldid=436103127). [Online; accessed 23-April-2012]. (Cited on pages 12 and 16.)

- [21] Wikipedia. *S-wave* — *Wikipedia, The Free Encyclopedia*, 2011. URL <http://en.wikipedia.org/w/index.php?title=S-wave&oldid=468110825>. [Online; accessed 1-February-2012]. (Cited on pages 50 and 56.)
- [22] Wikipedia. *Blasius boundary layer* — *Wikipedia, The Free Encyclopedia*, 2012. URL http://en.wikipedia.org/w/index.php?title=Blasius_boundary_layer&oldid=480776115. [Online; accessed 28-March-2012]. (Cited on page 208.)
- [23] Wikipedia. *Kelvin-Helmholtz instability* — *Wikipedia, The Free Encyclopedia*, 2012. URL http://en.wikipedia.org/w/index.php?title=Kelvin%E2%80%93Helmholtz_instability&oldid=484301421. [Online; accessed 4-April-2012]. (Cited on page 252.)
- [24] Wikipedia. *Plateau-Rayleigh instability* — *Wikipedia, The Free Encyclopedia*, 2012. URL http://en.wikipedia.org/w/index.php?title=Plateau%E2%80%93Rayleigh_instability&oldid=478499841. [Online; accessed 4-April-2012]. (Cited on page 252.)
- [25] Wikipedia. *Rayleigh-Taylor instability* — *Wikipedia, The Free Encyclopedia*, 2012. URL http://en.wikipedia.org/w/index.php?title=Rayleigh%E2%80%93Taylor_instability&oldid=483569989. [Online; accessed 4-April-2012]. (Cited on page 252.)
- [26] Wikipedia. *Curvature* — *Wikipedia, The Free Encyclopedia*, 2012. URL <http://en.wikipedia.org/w/index.php?title=Curvature&oldid=488021394>. [Online; accessed 25-April-2012]. (Cited on page 177.)
- [27] Wikipedia. *Froude number* — *Wikipedia, The Free Encyclopedia*, 2012. URL http://en.wikipedia.org/w/index.php?title=Froude_number&oldid=479498080. [Online; accessed 27-March-2012]. (Cited on page 188.)

- [28] Wikipedia. *Infinitesimal strain theory* — *Wikipedia, The Free Encyclopedia*, 2012. URL http://en.wikipedia.org/w/index.php?title=Infinitesimal_strain_theory&oldid=478640283. [Online; accessed 23-April-2012]. (Cited on pages 12 and 16.)
- [29] Wikipedia. *Love wave* — *Wikipedia, The Free Encyclopedia*, 2012. URL http://en.wikipedia.org/w/index.php?title=Love_wave&oldid=474355253. [Online; accessed 4-February-2012]. (Cited on pages 53 and 56.)
- [30] Wikipedia. *P-wave* — *Wikipedia, The Free Encyclopedia*, 2012. URL <http://en.wikipedia.org/w/index.php?title=P-wave&oldid=474119033>. [Online; accessed 1-February-2012]. (Cited on pages 49 and 56.)
- [31] Wikipedia. *Rayleigh wave* — *Wikipedia, The Free Encyclopedia*, 2012. URL http://en.wikipedia.org/w/index.php?title=Rayleigh_wave&oldid=473693354. [Online; accessed 4-February-2012]. (Cited on pages 53 and 56.)
- [32] Wikipedia. *Taylor-Couette flow* — *Wikipedia, The Free Encyclopedia*, 2012. URL http://en.wikipedia.org/w/index.php?title=Taylor%E2%80%93Couette_flow&oldid=483281707. [Online; accessed 10-April-2012]. (Cited on page 141.)